

PROJECT NAME

VORTEX

BASED ON

Bouteek Distorter Preamp

EFFECT TYPE

Overdrive / Amp-Like Distortion

BUILD DIFFICULTY

■■■■□ Intermediate

DOCUMENT VERSION

1.0.1 (2019-08-09)



PROJECT SUMMARY

A reproduction of an obscure and extremely rare drive pedal designed to reproduce Marshall-style high-gain amp tones.

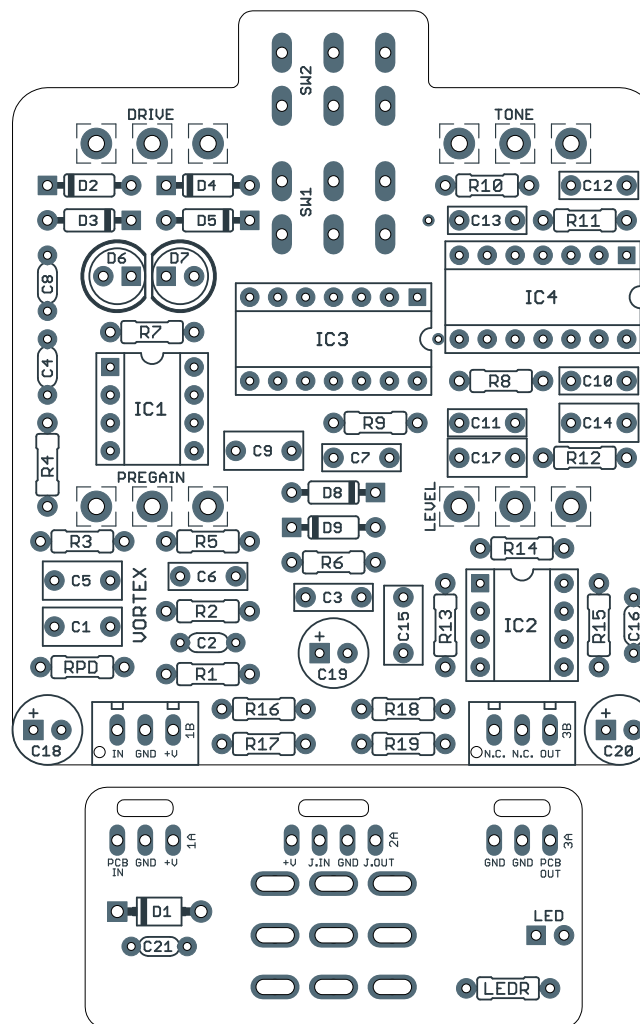

Actual size is 2.3" x 2.7" (main board) and 1.78" x 0.86" (bypass board).

TABLE OF CONTENTS

1	Project Overview	9	Drill Template
2	Introduction & Usage	10	Enclosure Layout
3-5	Parts List	11	Wiring Diagram
6-7	Build Notes	12	Licensing
8	Schematic	12	Document Revisions

INTRODUCTION

The Vortex Amp Distortion is a recreation of the Bouteek Distorter Preamp, a limited-release pedal from 2009 that flew largely under the radar. It was rumored to have the involvement of someone from Peavey, but otherwise very little is known about the company.

Bouteek released three other pedals. The Overdriver Preamp and the Twin Drive & Boost (Ultimate Drive) were both released in 2009. The Oil Cap Preamp followed in 2011. Each was only available for about a year or two. By mid-2015, Bouteek was fully extinct in the wild.

Circuit-wise, the Preamp Distorter is an interesting combination of familiar building blocks. It starts with two Tube Screamer drive stages with variable clipping options. From there, it goes into a Big Muff tone control stage. Using two CD4066 switches, it selects between two different sets of low-pass and high-pass filters used on both ends of the tone control. At the end, there is a gain recovery stage.

This project would not have been possible without the help of Paul Marossy. He did most of the work tracing the pedal several years ago, but ran into a couple of issues that caused it to be shelved before it was fully verified. Aion FX did a second pass to work out the problem areas and verify the tracing work independently, and then designed the PCB.

USAGE

The Vortex has the following controls:

- **Pregain** and **Drive** are the first two gain stages, simulating the setup of a high-gain amplifier.
- **Tone** pans between a high-pass and low-pass filter. The two filters themselves are impacted by the Tone toggle switch.
- **Volume** controls the overall output of the effect.
- **Clipping** (toggle switch) selects the clipping diodes which changes the character of the drive tone. In Vintage mode, both stages are clipped with silicon diodes. In Rectifier mode, the Pregain stage has no diodes while the Drive stage uses LEDs for clipping.
- **Tone** (toggle switch) selects between two different sets of high-pass and low-pass filters for the tone control, altering the frequency ranges that are panned by the Tone knob.

PARTS LIST

This parts list is also available in a spreadsheet format which can be imported directly into Mouser for easy parts ordering. Mouser doesn't carry all the parts (most notably potentiometers) so the second tab lists all the non-Mouser parts as well as sources for each.

[View parts list spreadsheet](#) →

PART	VALUE	TYPE	NOTES
R1	1M	Metal film resistor, 1/4W	
R2	16k	Metal film resistor, 1/4W	Can sub more common 15k with almost no difference in tone.
R3	47k	Metal film resistor, 1/4W	
R4	1k	Metal film resistor, 1/4W	
R5	47k	Metal film resistor, 1/4W	
R6	14k	Metal film resistor, 1/4W	Can sub more common 15k with almost no difference in tone.
R7	27k	Metal film resistor, 1/4W	
R8	8k2	Metal film resistor, 1/4W	
R9	27k	Metal film resistor, 1/4W	
R10	27k	Metal film resistor, 1/4W	
R11	220k	Metal film resistor, 1/4W	
R12	47k	Metal film resistor, 1/4W	
R13	100k	Metal film resistor, 1/4W	
R14	100k	Metal film resistor, 1/4W	
R15	220k	Metal film resistor, 1/4W	
R16	100k	Metal film resistor, 1/4W	
R17	100k	Metal film resistor, 1/4W	
R18	100k	Metal film resistor, 1/4W	
R19	100k	Metal film resistor, 1/4W	
RPD	2M2	Metal film resistor, 1/4W	Input pulldown resistor. Can be as low as 1M.
LEDR	4k7	Metal film resistor, 1/4W	LED current-limiting resistor. Adjust value to change LED brightness.
C1	1uF	Film capacitor, 7.2 x 3.5mm	
C2	150pF	MLCC capacitor, NP0/COG	
C3	47n	Film capacitor, 7.2 x 2.5mm	
C4	470pF	MLCC capacitor, NP0/COG	Original uses 500pF which is not a common value today.
C5	1uF	Film capacitor, 7.2 x 3.5mm	
C6	220n	Film capacitor, 7.2 x 2.5mm	
C7	47n	Film capacitor, 7.2 x 2.5mm	
C8	470pF	MLCC capacitor, NP0/COG	Original uses 500pF which is not a common value today.
C9	1uF	Film capacitor, 7.2 x 3.5mm	

PARTS LIST, CONT.

PART	VALUE	TYPE	NOTES
C10	22n	Film capacitor, 7.2 x 2.5mm	
C11	47n	Film capacitor, 7.2 x 2.5mm	
C12	2n2	Film capacitor, 7.2 x 2.5mm	
C13	22n	Film capacitor, 7.2 x 2.5mm	
C14	1uF	Film capacitor, 7.2 x 3.5mm	
C15	1uF	Film capacitor, 7.2 x 3.5mm	
C16	150pF	MLCC capacitor, NP0/C0G	
C17	1uF	Film capacitor, 7.2 x 3.5mm	
C18	100uF	Electrolytic capacitor, 6.3mm	Power supply filter capacitor.
C19	47uF	Electrolytic capacitor, 5mm	Reference voltage filter capacitor.
C20	47uF	Electrolytic capacitor, 5mm	Reference voltage filter capacitor.
C21	100n	MLCC capacitor, X7R	Power supply filter capacitor.
D1	1N5817	Schottky diode, DO-41	
D2	1N914	Fast-switching diode, DO-35	
D3	1N914	Fast-switching diode, DO-35	
D4	1N914	Fast-switching diode, DO-35	
D5	1N914	Fast-switching diode, DO-35	
D6	5mm LED	LED, 5mm, red diffused	Can also use 3mm.
D7	5mm LED	LED, 5mm, red diffused	Can also use 3mm.
D8	1N914	Fast-switching diode, DO-35	
D9	1N914	Fast-switching diode, DO-35	
IC1	JRC4558D	Operational amplifier, DIP8	
IC1-S	DIP-8 socket	IC socket, DIP-8	
IC2	JRC4558D	Operational amplifier, DIP8	
IC2-S	DIP-8 socket	IC socket, DIP-8	
IC3	CD4066BE	CMOS quad analog switch, DIP14	
IC3-S	DIP-14 socket	IC socket, DIP-14	
IC4	CD4066BE	CMOS quad analog switch, DIP14	
IC4-S	DIP-14 socket	IC socket, DIP-14	
PRE	500kB	16mm right-angle PCB mount pot	
DRIVE	500kB	16mm right-angle PCB mount pot	
TONE	100kB	16mm right-angle PCB mount pot	
LEVEL	100kB	16mm right-angle PCB mount pot	
SW1	DPDT on-on	Toggle switch, DPDT on-on	Selects the clipping diodes for the first two gain stages.
SW2	DPDT on-on	Toggle switch, DPDT on-on	Selects between two different sets of filters for the tone control.

PARTS LIST, CONT.

PART	VALUE	TYPE	NOTES
LED	5mm	LED, 5mm, red diffused	
IN	1/4" stereo	1/4" phone jack, closed frame	Switchcraft 112BX or equivalent.
OUT	1/4" mono	1/4" phone jack, closed frame	Switchcraft 111X or equivalent.
DC	2.1mm	DC jack, 2.1mm panel mount	Mouser 163-4302-E or equivalent.
FSW	3PDT	Stomp switch, 3PDT	
ENC	125B	Enclosure, die-cast aluminum	Can also use a Hammond 1590N1.

BUILD NOTES

Switches

The original unit has a single toggle switch for either “Rectifier” or “Vintage” mode. Inside, it’s a 4PDT, with two of the poles controlling the clipping diodes and two of the poles controlling the filters in the tone section. To provide added flexibility, and also because 4PDT switches are clumsy and somewhat hard to find, this single switch has been split out into two.

Clipping switch

The clipping switch allows you select between different sets of diodes for the two gain stages. One half of the switch selects the diodes of the first stage (either two silicon diodes for “Vintage” mode, or no clipping for “Rectifier” mode) and the other half of the switch selects the diodes of the second stage (two silicons for “Vintage” or two LEDs for “Rectifier”).

Tone switch

If you look at the schematic, this section looks pretty complex due to the CD4066 switching, but it really just comes down to each side of the tone control having a different filter value (one resistor and one capacitor) depending on whether it’s Vintage or Rectifier mode. The DPDT switch becomes eight SPST switches so that a filter is fully out of the circuit when the other one is engaged.

See next page for more in-depth info on how the tone control behaves and what exactly the toggle switch does to the sound.

BUILD NOTES

Tone control analysis

The tone control is based on the standard Big Muff-style control that fades between a low-pass filter (bass emphasis, cutting treble) and a high-pass filter (treble emphasis, cutting bass). Here are graphs showing how the tone control behaves in the different modes.

VINTAGE MODE

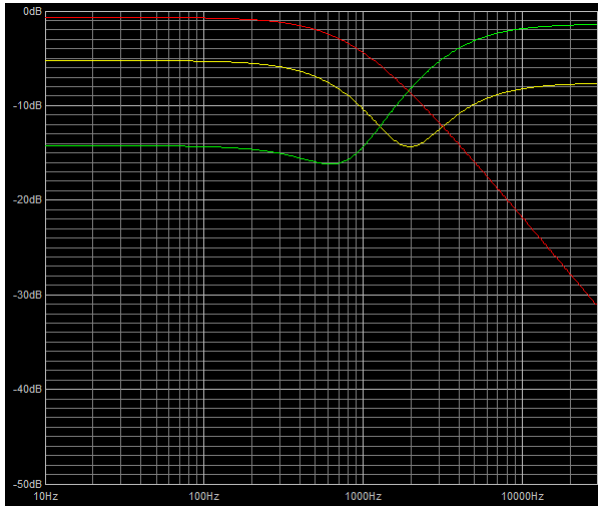

RECTIFIER MODE

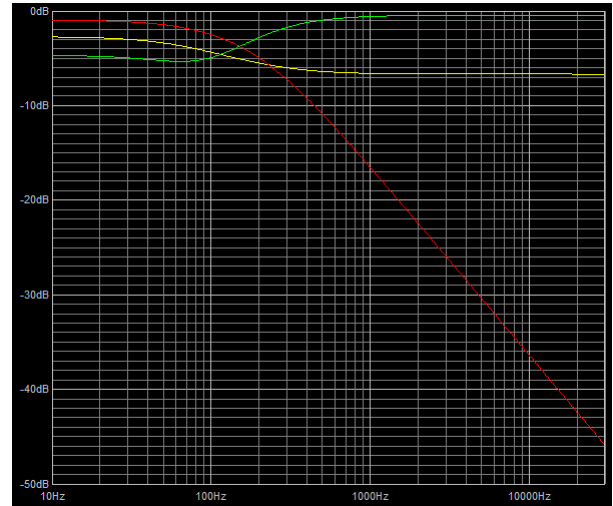

Key:

- Red: 0% rotation (full bass)
- Yellow: 50% rotation (midpoint)
- Green: 100% rotation (full treble)

In Vintage mode, the EQ in the 12:00 position is very similar to a Big Muff with a scooped midrange. In Rectifier mode, however, it's largely flat in the middle, with only a slight bass emphasis. The treble side provides a slight treble increase while the bass side cuts treble significantly. As a result, in Rectifier mode, the entire character of the control changes, and it becomes basically just a treble control that cuts to the left.

SCHEMATIC

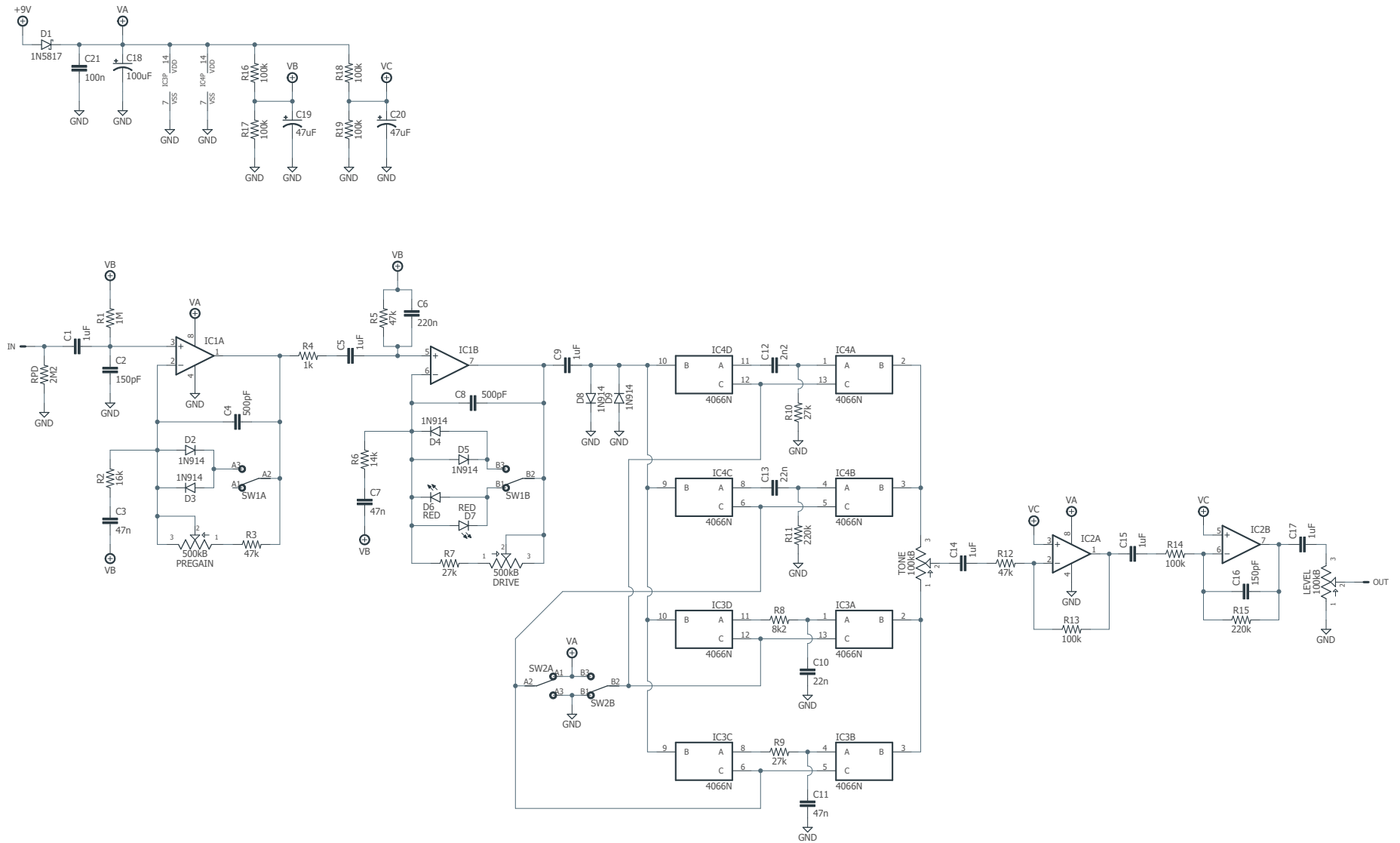

DRILL TEMPLATE

Cut out this drill template, fold the edges and tape it to the enclosure. Before drilling, it's recommended to first use a center punch for each of the holes to help guide the drill bit.

Ensure that this template is printed at 100% or "Actual Size". You can double-check this by measuring the scale on the printed page.

Top jack layout assumes the use of closed-frame jacks like the [Switchcraft 111X](#). If you'd rather use open-frame jacks, please refer to the Open-Frame Jack Drill Template for the top side.

LED hole drill size assumes the use of a [5mm LED bezel](#), available from several parts suppliers. Adjust size accordingly if using something different, such as a 3mm bezel, a plastic bezel, or just a plain LED.

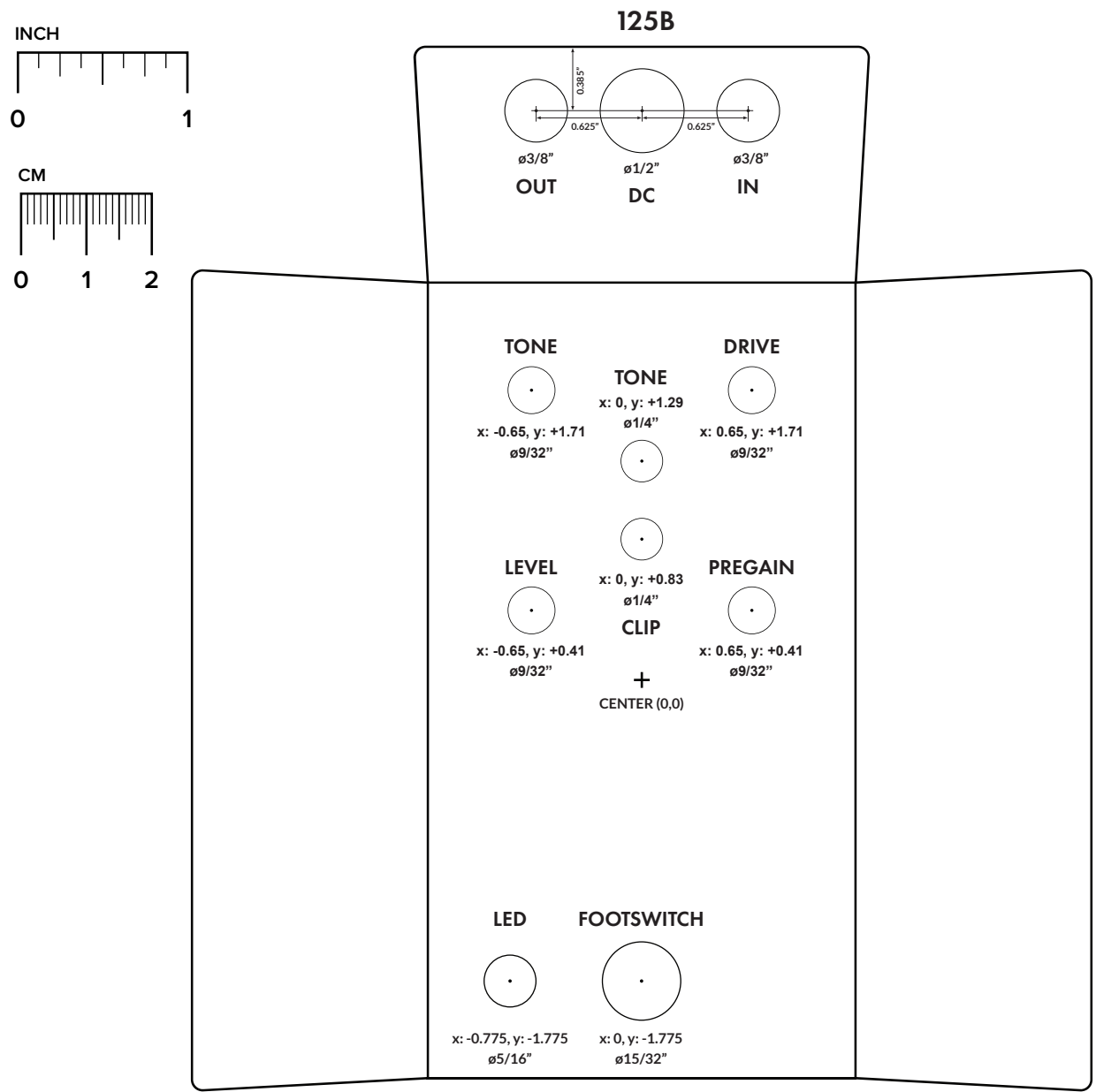

ENCLOSURE LAYOUT

Enclosure is shown without jacks. See next page for jack layout and wiring.

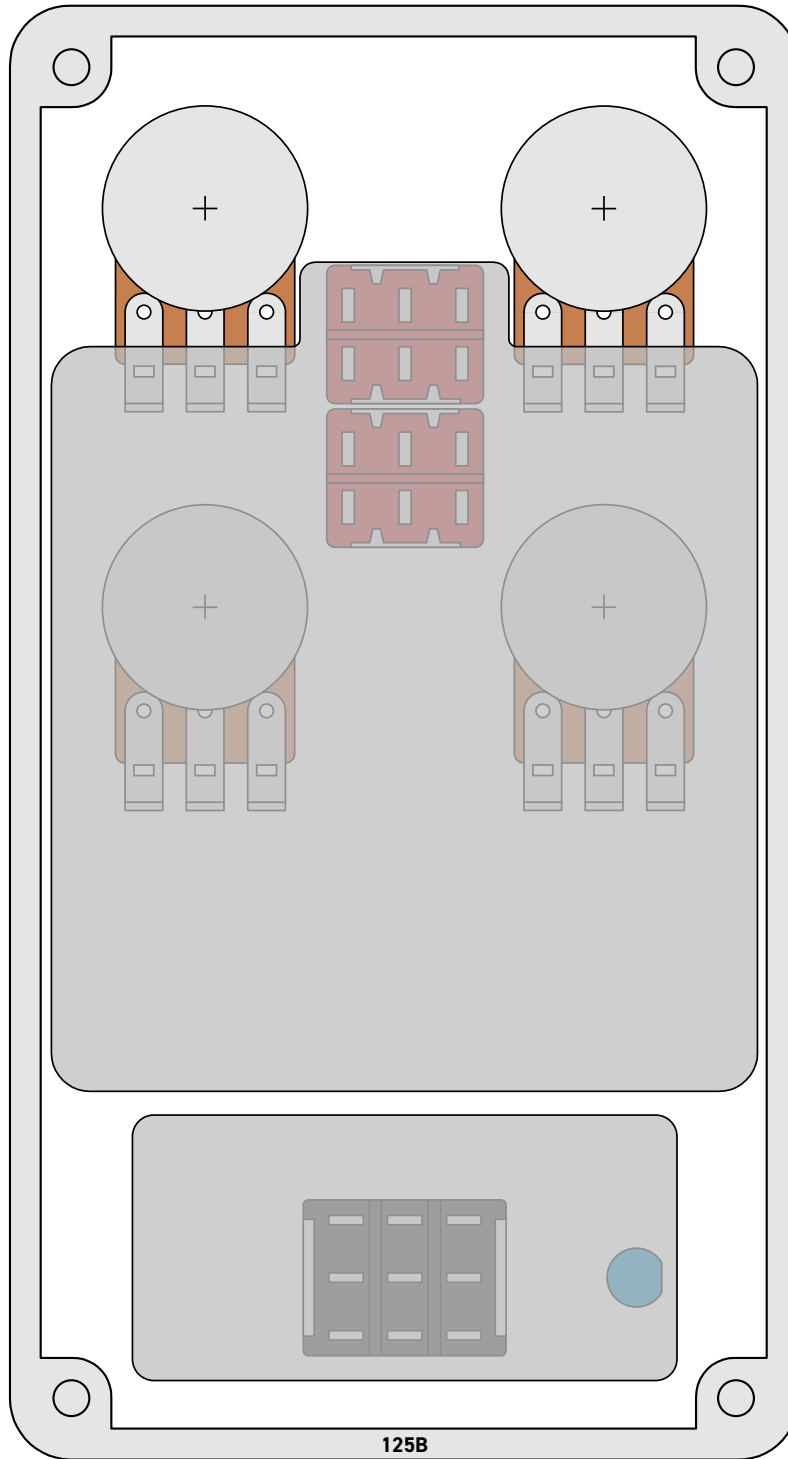

WIRING DIAGRAM

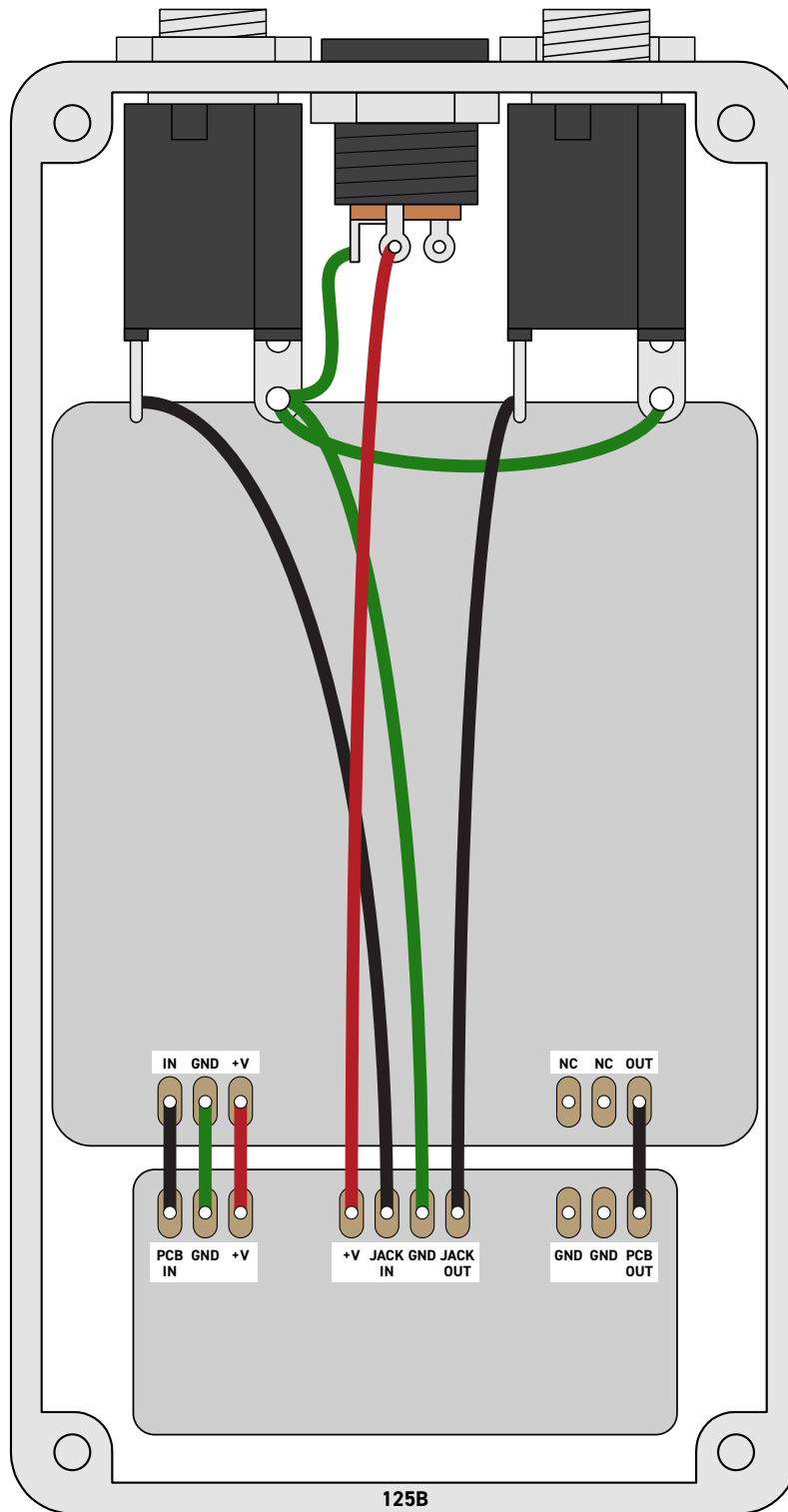

LICENSE & USAGE

No direct support is offered for these projects beyond the provided documentation. It's assumed that you have at least some experience building pedals before starting one of these. Replacements and refunds cannot be offered unless it can be shown that the circuit or documentation are in error.

All of these circuits have been tested in good faith in their base configurations. However, not all the modifications or variations have necessarily been tested. These are offered only as suggestions based on the experience and opinions of others.

Projects may be used for commercial endeavors in any quantity unless specifically noted. No attribution is necessary, though a link back is always greatly appreciated. The only usage restrictions are that **(1) you cannot resell the PCB as part of a kit without prior arrangement, and (2) you cannot "goop" the circuit, scratch off the screenprint, or otherwise obfuscate the circuit to disguise its source.** (In other words: you don't have to go out of your way to advertise the fact that you use these PCBs, but please don't go out of your way to hide it. The guitar effects industry needs more transparency, not less!)

DOCUMENT REVISIONS

1.0.1 (2019-08-09)

Corrected drill template. (Tone & Clip were labeled opposite)

1.0.0 (2019-03-03)

Initial release.