

PROJECT NAME

STRAYLIGHT



BASED ON

Shin-ei/Univox Uni-Vibe®

BUILD DIFFICULTY

■■■■□ Advanced

EFFECT TYPE

Chorus/phaser/vibrato

DOCUMENT VERSION

1.0.1 (2024-07-08)

PROJECT SUMMARY

Originally designed as a simulation of a Leslie spinning speaker cabinet, it uses an incandescent bulb and LDRs to produce an asymmetrical phase-shift effect. It was most famously used by Jimi Hendrix.

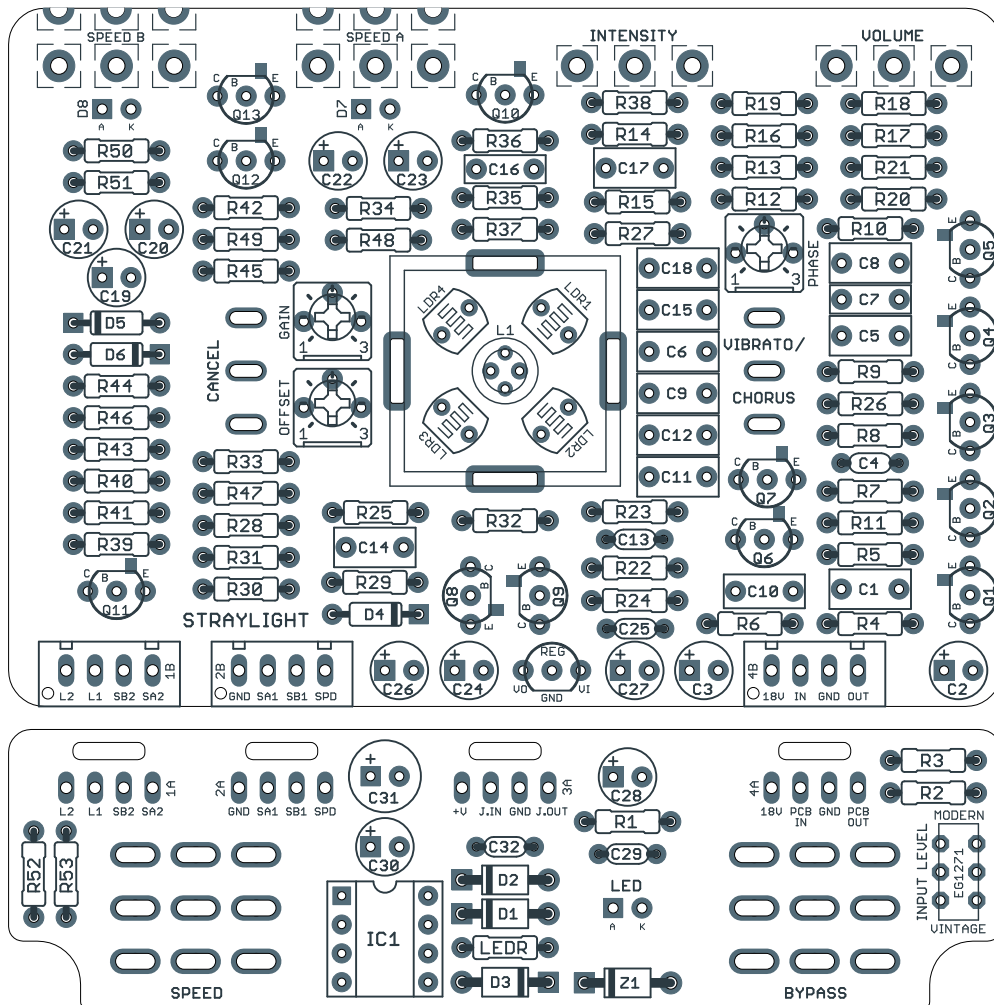

Actual size is 3.45" x 2.42" (main board) and 3.45" x 0.97" (bypass board).

TABLE OF CONTENTS

1	Project Overview	16	Drill Template
2	Introduction	17	Enclosure Layout
3-4	Usage & Design Notes	18	Wiring Diagram
5-8	Parts List	19	Licensing
9-14	Build Notes	19	Document Revisions
15	Schematics		

INTRODUCTION

The Straylight Chorus/Vibe is an adaptation of the Univox Uni-Vibe, one of the earliest modulation effects originally released in 1967. It was most famously used by Jimi Hendrix, but it's been used and adored by countless other professional musicians across its nearly sixty-year history.

The Uni-Vibe circuit is really a four-stage optical phaser as opposed to a true pitch-shifting vibrato, but aspects of the implementation (particularly the uneven capacitors in each stage) cause it to have a Doppler effect similar to a Leslie spinning speaker. The phase-shifted output can either be used on its own or mixed with the dry signal for a chorus effect.

The Uni-Vibe uses a miniature incandescent lamp with four LDRs inside of a reflective box, and this is a key aspect of its sound. There have been many simplified versions of the circuit that use an LED or vactrols in place of the lamp and box, for example the Earthquaker Devices Depths and Danelectro® Chicken Salad, as well as the classic DIY [EasyVibe by John Hollis](#). While they are excellent effects in their own right, they are all approximations of the real thing.

The Straylight project is a direct clone of the original Uni-Vibe circuit, but with some added features and modern conveniences. We have added a charge pump voltage doubler so that it can run off of a standard 9VDC supply instead of wall power like the original. Like most clones, ours does not support a rocker pedal for the speed control, but we have added a second Speed pot on a footswitch so you can transition between two preset speeds with ramp-up/ramp-down effect between the settings.

The original Uni-Vibe handled bypass mode by deactivating the LFO, so the signal still passes through the static phase-shift stages. This imparts a subtle coloration to the tone that many people like. So while standard true bypass is a better option all-around, we've included a toggle switch for Cancel mode so that this feature is still available.

The last feature is an internal slide switch to set the input level. The original unit had a significant volume drop at the input, cutting the signal by 1/3, which was responsible for the weak output. Some clones add an input buffer to help with this.

However, the issue is entirely caused by the 22k/47k resistors acting as a voltage divider. A much simpler solution is to just increase the value of the ground resistor to something much higher, such as 2.2M. But again, while this low impedance is a flaw in the circuit design, it's grown to become part of the sound, so we've made both options available.

USAGE

The Straylight has four knobs:

- **Speed 1** and **Speed 2** set the speed of the modulation cycle, with a footswitch to select between the two settings. The effect ramps gradually between the two settings when they are changed.
- **Intensity** sets the depth of the modulation effect.
- **Volume** is the output volume of the effect.

There are also two toggle switches:

- **Chorus/Vibe** selects between vibrato mode (effect only) and chorus mode (effect mixed with the dry signal). Vibe mode works best on faster speeds, since the slow phase shift by itself is not as noticeable without the dry signal as a reference point.
- **Cancel** disables the lamp modulation, but still allows the signal to pass through all of the static phase stages. This is how the original Uni-Vibe was bypassed, and it does provide a subtle coloration to the tone compared to standard true bypass.

DESIGN NOTES

Power supply

The Uni-Vibe ran on AC wall power with a transformer. The lamp driver circuit was supplied with around 22VDC, while the audio path was powered from an isolated and heavily filtered (but unregulated) 16V.

For our adaptation, we evaluated a few different ways of powering the circuit. In the end we determined that the best method available today is to use a charge pump doubler to get 18V from a standard 9V supply. The raw 18V is used for the LFO and lamp driver, and a regulated 15V is used for audio.

Since the lamp is driven by current rather than voltage, the actual difference in supply voltage is insignificant and there is no reason to use a full 22V supply. The audio path is powered with a solid 15V, and the regulator has enough headroom that the supply does not fluctuate at all with the lamp's wide variance in current draw.

Light shield

The original Uni-Vibe enclosed the lamp and LDRs in a reflective sheet-metal box that served two purposes: 1) to isolate the LDRs from light other than the lamp, and 2) to reflect the light internally so that all four LDRs are evenly exposed.

The Uni-Vibe has been a staple of the DIY community for over 30 years, and this light shield has been implemented in many different ways during that time. R.G. Keen suggested a specially-trimmed 35mm film canister. Others have used a 3/4" copper pipe end cap from the hardware store, or even a bottle cap, as in the Madbean Harbinger. And some don't use a shield at all, reasoning that the pedal is protected from outside light once the lid is on.

But other than the original sheet metal light shield, we've not seen a method that checks all the boxes. Most are cumbersome to install and many do not have a reflective interior.

DESIGN NOTES, CONT.

So for this project we took an entirely new approach, using interlocking PCBs to build a [light shield](#) that can be soldered in place. The inside is reflective, and the top is removable in case you need to troubleshoot or if you want to swap out the lamp or LDRs.

Like the original shield, it is not perfectly sealed from outside light. The reflective interior is the more significant feature. With that said, it still blocks ~98% of the light when the enclosure lid is open, and 100% when it's closed.

Our light shield is not a requirement for the build. The slotted pads on the PCB can fit a variety of other solutions, such as a sheet metal box bent to the right size (0.8" / 20.3mm square). If it's a solderable metal, it can be soldered in place. Otherwise, you could cut tabs the size of the slots and bend them outward underneath. The slotted pads have no electrical connection to the rest of the circuit.

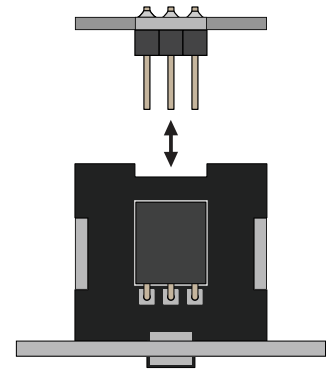

Cancel switch

The original Uni-Vibe's bypass switch was a simple connection to disconnect the lamp from the LFO, which puts the LDRs into their dark resistance range (in the mega-ohms) and passes full-frequency signal. However, there is a coloration that happens in bypass mode that some people like.

In this project, we opted to use true bypass, but we included a toggle switch for Cancel mode so that this coloration is still available, similar to Spectral mode in our [Quadratron](#) project (Lovetone Doppelganger).

If for some reason you want to wire this offboard, the bottom pad of the Cancel switch (immediately above R33) is where you want to tap in. There's not much room inside the enclosure for a third footswitch, but you could easily wire an external jack and use a miniature latching footswitch.

You can even keep the Cancel toggle switch installed on the PCB. Just know that if either switch is in cancel mode, it overrides the other, but not the other way around.

One other interesting side-effect of Cancel mode is that the LDRs are still fully functional. This means that if you vary the amount of light they are exposed to, you'll get light-sensitive modulation or expression. It's not practical for live use, but you can get some very unique sounds by removing the light shield cover and waving your hand over the LDRs.

PARTS LIST

This parts list is also available in a spreadsheet format which can be imported directly into Mouser for easy parts ordering. Mouser doesn't carry all the parts—notably potentiometers—so the second tab lists all the non-Mouser parts as well as sources for each.

[View parts list spreadsheet](#) →

PART	VALUE	TYPE	NOTES
R1	22k	Metal film resistor, 1/4W	
R2	47k	Metal film resistor, 1/4W	
R3	2M2	Metal film resistor, 1/4W	
R4	1M2	Metal film resistor, 1/4W	
R5	1M2	Metal film resistor, 1/4W	
R6	100k	Metal film resistor, 1/4W	
R7	47k	Metal film resistor, 1/4W	
R8	6k8	Metal film resistor, 1/4W	
R9	4k7	Metal film resistor, 1/4W	
R10	3k3	Metal film resistor, 1/4W	
R11	1k2	Metal film resistor, 1/4W	
R12	75k	Metal film resistor, 1/4W	
R13	75k	Metal film resistor, 1/4W	
R14	47k	Metal film resistor, 1/4W	
R15	220k	Metal film resistor, 1/4W	
R16	4k7	Metal film resistor, 1/4W	
R17	100k	Metal film resistor, 1/4W	
R18	100k	Metal film resistor, 1/4W	
R19	47k	Metal film resistor, 1/4W	
R20	4k7	Metal film resistor, 1/4W	
R21	4k7	Metal film resistor, 1/4W	
R22	4k7	Metal film resistor, 1/4W	
R23	100k	Metal film resistor, 1/4W	
R24	100k	Metal film resistor, 1/4W	
R25	47k	Metal film resistor, 1/4W	
R26	4k7	Metal film resistor, 1/4W	
R27	4k7	Metal film resistor, 1/4W	
R28	4k7	Metal film resistor, 1/4W	
R29	100k	Metal film resistor, 1/4W	
R30	100k	Metal film resistor, 1/4W	
R31	47k	Metal film resistor, 1/4W	
R32	4k7	Metal film resistor, 1/4W	

PARTS LIST, CONT.

PART	VALUE	TYPE	NOTES
R33	4k7	Metal film resistor, 1/4W	
R34	4k7	Metal film resistor, 1/4W	
R35	100k	Metal film resistor, 1/4W	
R36	68k	Metal film resistor, 1/4W	
R37	47k	Metal film resistor, 1/4W	
R38	22k	Metal film resistor, 1/4W	
R39	3k3	Metal film resistor, 1/4W	
R40	4k7	Metal film resistor, 1/4W	
R41	2M2	Metal film resistor, 1/4W	
R42	220k	Metal film resistor, 1/4W	
R43	220k	Metal film resistor, 1/4W	
R44	4k7	Metal film resistor, 1/4W	
R45	4k7	Metal film resistor, 1/4W	
R46	68R	Metal film resistor, 1/4W	
R47	47k	Metal film resistor, 1/4W	
R48	4k7	Metal film resistor, 1/4W	
R49	1M5	Metal film resistor, 1/4W	Part of rate indicator mod. See build notes.
R50	3k3	Metal film resistor, 1/4W	Part of rate indicator mod. See build notes.
R51	3k3	Metal film resistor, 1/4W	Part of rate indicator mod. See build notes.
R52	2k2	Metal film resistor, 1/4W	Sets maximum speed. Most vintage units use 4k7.
R53	2k2	Metal film resistor, 1/4W	Sets maximum speed. Most vintage units use 4k7.
LED R	10k	Metal film resistor, 1/4W	
C1	1uF	Film capacitor, 7.2 x 3.5mm	
C2	1uF	Electrolytic capacitor, 4mm	
C3	10uF	Electrolytic capacitor, 5mm	
C4	330pF	MLCC capacitor, NP0/COG	
C5	1uF	Film capacitor, 7.2 x 3.5mm	
C6	1uF	Film capacitor, 7.2 x 3.5mm	
C7	15n	Film capacitor, 7.2 x 2.5mm	
C8	1uF	Film capacitor, 7.2 x 3.5mm	
C9	1uF	Film capacitor, 7.2 x 3.5mm	
C10	220n	Film capacitor, 7.2 x 2.5mm	
C11	1uF	Film capacitor, 7.2 x 3.5mm	
C12	1uF	Film capacitor, 7.2 x 3.5mm	
C13	470pF	MLCC capacitor, NP0/COG	
C14	1uF	Film capacitor, 7.2 x 3.5mm	
C15	1uF	Film capacitor, 7.2 x 3.5mm	

PARTS LIST, CONT.

PART	VALUE	TYPE	NOTES
C16	4n7	Film capacitor, 7.2 x 2.5mm	
C17	1uF	Film capacitor, 7.2 x 3.5mm	
C18	1uF	Film capacitor, 7.2 x 3.5mm	
C19	1uF	Electrolytic capacitor, 4mm	
C20	1uF	Electrolytic capacitor, 4mm	
C21	1uF	Electrolytic capacitor, 4mm	
C22	10uF	Electrolytic capacitor, 5mm	
C23	10uF	Electrolytic capacitor, 5mm	
C24	47uF	Electrolytic capacitor, 5mm	Power supply filter capacitor.
C25	470n	MLCC capacitor, X7R	Power supply filter capacitor.
C26	47uF	Electrolytic capacitor, 5mm	Power supply filter capacitor.
C27	47uF	Electrolytic capacitor, 5mm	Power supply filter capacitor.
C28	47uF	Electrolytic capacitor, 5mm	Power supply filter capacitor.
C29	470n	MLCC capacitor, X7R	Power supply filter capacitor.
C30	10uF	Electrolytic capacitor, 5mm	
C31	100uF	Electrolytic capacitor, 6.3mm	Power supply filter capacitor.
C32	470n	MLCC capacitor, X7R	Power supply filter capacitor.
D1	1N5817	Schottky diode, DO-41	
D2	1N5817	Schottky diode, DO-41	
D3	1N5817	Schottky diode, DO-41	
D4	BAT48	Schottky diode, DO-35	
D5	1N914	Fast-switching diode, DO-35	
D6	1N914	Fast-switching diode, DO-35	
D7	3mm LED	LED, 3mm, red diffused	Part of the rate indicator mod. See build notes.
D8	3mm LED	LED, 3mm, red diffused	Part of the rate indicator mod. See build notes.
Z1	1N4741A	Zener diode, 11V, DO-41	
Q1	2N5089	BJT transistor, NPN, TO-92	
Q2	2N5088	BJT transistor, NPN, TO-92	
Q3	2N5088	BJT transistor, NPN, TO-92	
Q4	2N5088	BJT transistor, NPN, TO-92	
Q5	2N5088	BJT transistor, NPN, TO-92	
Q6	2N5088	BJT transistor, NPN, TO-92	
Q7	2N5088	BJT transistor, NPN, TO-92	
Q8	2N5088	BJT transistor, NPN, TO-92	
Q9	2N5088	BJT transistor, NPN, TO-92	
Q10	2N5088	BJT transistor, NPN, TO-92	
Q11	KSP13	Darlington BJT transistor, NPN	MPSA13 equivalent.

PARTS LIST, CONT.

PART	VALUE	TYPE	NOTES
Q12	KSP13	Darlington BJT transistor, NPN, TO-92	MPSA13 equivalent.
Q13	2N5087	BJT transistor, PNP, TO-92	Part of the rate indicator mod. See build notes.
REG	78L15	Regulator, +15V, TO-92	
IC1	LT1054CP	Charge pump / voltage converter, DIP-8	
IC1-S	DIP-8 socket	IC socket, DIP-8	
L1	2174 lamp	Incandescent lamp, 12V/40mA	See build notes for possible lamp substitutes.
LDR1	PDV-P9203	LDR, 10-30k light, 5M dark	See build notes for possible LDR substitutes.
LDR2	PDV-P9203	LDR, 10-30k light, 5M dark	See build notes for possible LDR substitutes.
LDR3	PDV-P9203	LDR, 10-30k light, 5M dark	See build notes for possible LDR substitutes.
LDR4	PDV-P9203	LDR, 10-30k light, 5M dark	See build notes for possible LDR substitutes.
SPEED A	100kC dual	16mm dual pot, right angle	
SPEED B	100kC dual	16mm dual pot, right angle	
INTENSITY	50kB	16mm right-angle PCB mount pot	
VOLUME	100kB	16mm right-angle PCB mount pot	
CH/VIBE	SPDT on-on	Toggle switch, SPDT on-on	
CANCEL	SPDT on-on	Toggle switch, SPDT on-on	
INPUT	SPDT slide	Slide switch, miniature, SPDT	E-Switch EG1271
GAIN	500R trimmer	Trimmer, 10%, 1/4"	Bourns 3362P
OFFSET	100k trimmer	Trimmer, 10%, 1/4"	Bourns 3362P
PHASE	50k trimmer	Trimmer, 10%, 1/4"	Bourns 3362P
LED	5mm	LED, 5mm, red diffused	
IN	1/4" mono	1/4" phone jack, closed frame	Switchcraft 111X or equivalent.
OUT	1/4" mono	1/4" phone jack, closed frame	Switchcraft 111X or equivalent.
DC	2.1mm	DC jack, 2.1mm panel mount	Mouser 163-4302-E or equivalent.
BYPASS	3PDT	Stomp switch, 3PDT	
SPEED	3PDT	Stomp switch, 3PDT	
ENCLOSURE	1590BBS	Enclosure, die-cast aluminum	

BUILD NOTES

Lamp selection

We recommend using the JKL 2174 (12V/40mA) or 2102 (18V/40mA) lamps, which emit light at all angles and can be installed flush with the PCB. These are available from [Mouser](#).

The incandescent lamp is a key part of the characteristic Uni-Vibe sound and a big part of what sets it apart from other phasers. Unlike an LED, an incandescent lamp operates thermally—the light is created by the voltage and current being converted into heat. This means that the light pulse lags behind the voltage slightly, and it doesn't track perfectly with the LFO. There have been many adaptations of the Uni-Vibe that use LEDs, but the lamp is a key part of its sound and LEDs won't work the same.

According to R.G. Keen, the original Uni-Vibe used a 28V/40mA lamp. The rated voltage doesn't matter very much. 12V or 18V lamps are much more readily available and will perform the same.

Many of the lamps recommended in DIY Uni-Vibes are in what's called a "bi-pin" package. They are mounted to a plastic base and the pins are evenly spaced for easier PCB installation. These work fine, and the PCB footprint in our project is compatible with either a 0.1" lead spacing (8099SBP) or a 0.125" lead spacing (7371). However, for these bi-pin types, the plastic base covers up the bottom half of the bulb and also elevates it much higher above the PCB.

It may not make a significant difference due to the reflective light shield that disperses the light, but the non-based lamp is the type used in the original Uni-Vibe. They are just as easy to find as the bi-pin type, and since the physical construction is an important part of the Uni-Vibe sound, it's safest to keep as close to the original as possible, moreso than most other effects.

Lamp placement

Incandescent lamps are not polarized, so just use either the left & right or the top & bottom pads on the PCB. The two pairs of pads are spaced differently to allow the use of either 0.1" or 0.125" bi-pin lamps, but the connections are the same either way regardless of orientation.

LDR selection

The original Uni-Vibe used a custom photocell with no cross reference to a standard manufacturer part number. The exact specs are not known, but in decades of DIY work on this circuit, many different types have been used successfully. As with most other Uni-Vibe adaptations, the Straylight includes a few different ways to tweak the operation of the lamp for best operation.

Above all, the important characteristic for the LDRs is a high dynamic range, around 10k to 100k under illumination, with a dark resistance of 5M to 20M. The PDV-P9203 is probably the easiest type to find that meets these specifications. It's readily available from Mouser and Digikey. The NSL-5542 is another option with similar specs, but as of this writing is only available from RS (formerly Allied).

The rise and fall time is also important, particularly if you plan to use it at fast settings, but don't be too concerned with this spec—most LDRs fall in similar ranges, and the lamp's inability to turn on and off quickly will have much more impact on the speed characteristics of the filters.

BUILD NOTES, CONT.

Do the LDRs need to be matched?

One last discussion point: since it's a phaser, the question often comes up whether the LDRs need to be matched in any way. [According to R.G. Keen](#), there does not seem to be any clear benefit to matching in this circuit, and as long as you use the same part number with the same nominal resistance range, you can get all the classic Uni-Vibe tones. The phase stages are already designed to be uneven due to the staggered capacitor values.

However, if you still want to try matching them, it's not terribly difficult as long as you have a batch of ten or twenty of them to choose from. Install them on their own rows on a breadboard, all legs electrically isolated, LDR pointing upward, exposed to the same light from the same angle. Then measure the resistance between the legs and choose the four whose resistance value is closest.

Biasing

There are two trimmers on the PCB that are used to calibrate the circuit. "Gain" and "Offset" directly control the lamp brightness and behavior and can be used to compensate for different lamps as well as different LDRs.

The behavior of these two trimmers is illustrated in the following diagram:

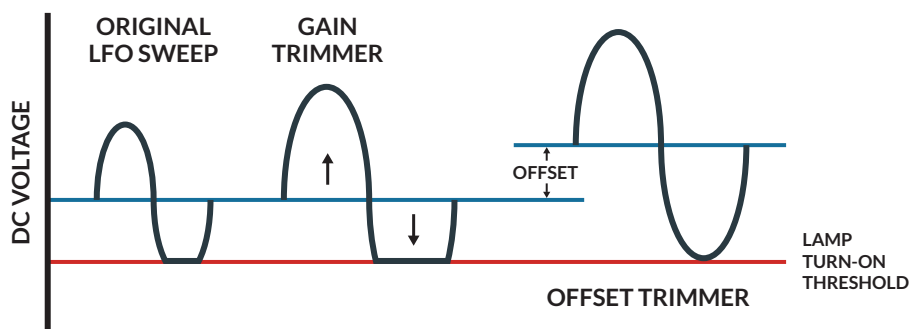

The **Gain** trimmer adjusts the overall amplitude range of the lamp's sweep, making it both brighter at the top end of the sweep and darker at the bottom.

The lamp has a fixed voltage threshold where it turns on, so the **Offset** trimmer is used to shift the range upward so that it only turns off at the very bottom of the sweep. If Gain is adjusted again, Offset will likely need to be as well.

The next two sections discuss the function of each trimmer in more detail.

Gain trimmer

This sets the gain of the lamp driver. As you turn it up, the lamp will increase in average brightness.

Start with this trimmer at 25% rotation, or around 10:00. Ensure the Offset and Phase trimmers are at 12:00. Turn Intensity all the way down, then adjust the trimmer until the lamp is dim but glowing. Then turn Intensity all the way back up and listen.

BUILD NOTES, CONT.

Note that even with the light shield installed, a small amount of light will still get in if you are testing in direct light with the enclosure lid removed, and this will affect the sound. You may want to replace the lid loosely when listening.

This trimmer is the primary way of compensating for different types of LDRs, so the lamp may need to be brighter or dimmer than this recommendation in order to get the LDR resistance into the correct range. Ultimately, as with the Gain trimmer, just use your ears and leave it where it sounds best.

Some original Uni-Vibes used this trimmer, while others omitted it and just used a fixed resistor. If you want to leave it off, jumper pins 2 and 3 of the trimmer and use 150R for R46, but note that you may have a hard time getting it to sound right if your LDRs aren't identical in specs to the original.

Offset trimmer

This adjusts the DC bias point of the LFO going into the lamp driver. Lamps have a fixed turn-on threshold voltage, and this threshold may differ from lamp to lamp. This trimmer allows the LFO voltage range to be adjusted until the lamp cuts off at the very bottom.

With the Speed control set low, start with the trimmer at around noon and then adjust until the lamp goes dark at the bottom of the sweep. The goal is to have the biggest dynamic range between the top and bottom of the sweep—although be aware that due to the thermal time constant of the lamp, it may not be able to get fully dark on faster speeds. You may need to go back and forth a few times between Gain and Offset adjustments before you get it right.

Some other implementations of this modification use a 100k trimmer with a 4k7 resistor for R48. This allows you to get the exact voltage divider ratio of the original (47k/100k) on the far end, but with a smaller range of adjustability.

Others dispensed with R47 and R48 and just used the 250k trimmer connected to ground and +V at either end. But with no minimum or maximum resistance values, this causes the LFO to malfunction at the extremes of the rotation. It seems that the 250k/47k/47k combination provides the best balance of adjustability, and so that is what we've specced for this project.

If you want to leave it off, use 100k for R48 and jumper pins 1, 2 and 3 of the trimmer.

Phase trimmer

This trimmer does not impact the lamp's behavior, but sets the balance of phased signal to dry signal when in Chorus mode. For best phasing, these two signals should be as close in amplitude as possible, but due to component tolerances and other factors, they don't always line up

This should be the last trimmer you set, after the other two. Set it to 12:00 (50%) to start with. After biasing the lamp, ensure the mode is set to Chorus and set Intensity to full, then adjust this trimmer to the left and right while listening for an improvement in the phasing. Leave it where the phased sound is deepest. If you don't notice any difference, just leave it at 12:00.

Of the three trimmers, this is the only one whose usefulness is only marginal. It may make a huge difference in some builds, but in ours it did not. To omit it, jumper all 3 pads together.

BUILD NOTES, CONT.

Transistor selection

The original Uni-Vibe used 2SC828 transistors for all but Q1, which used 2SC539. The 2SC539 has slightly lower noise and higher h_{FE} (gain) than the 2SC828, and this is likely the reason it was specified.

These transistors are long obsolete and there are much better options available today. We recommend the 2N5089 for Q1 and 2N5088 for Q2-Q10. You can also use the BC549C for all of them, but note that the pinout is reversed so they will need to be rotated 180 degrees from the silkscreen on the PCB.

For Q11 and Q12, which are used for the LFO and lamp driver, the MPSA13 Darlington is the best choice due to its much higher current handling. The Uni-Vibe did not take any special precautions for these two transistors, and as a result they tended to fail over time, particularly Q12. The MPSA13 is obsolete, but the KSP13 is an identical part and still in production from ON Semi.

The transistor outlines also include a rectangular collector pad above the “B” and “E” pins so that SMD transistors can be used. The BC849C is a good substitute for 2N5088/2N5089. It’s recommended to stay with the through-hole KSP13 for Q11 and Q12 since the TO-92 package has much better power dissipation, which means they are less likely to fail (and easier to change out if they ever do).

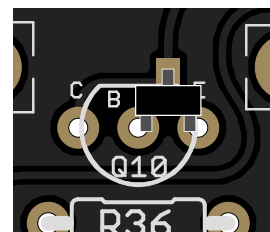

Speed indicator LEDs

R49-51, D7-8 and Q13 are part of the rate indicator circuit. The LED indicates which of the two Speed knobs is in effect, and the active LED also flashes with the rate.

Since it is in parallel with the lamp, the LED brightness is also directly affected by the Intensity control and the Gain and Offset trimmers. This means that if Intensity is all the way down, the LEDs will barely flash at all, so make sure it’s turned up before concluding that something is wrong. The rate flash is also much less intense on slower speeds.

Set the bias first and get it sounding the way you want, and then if the LED brightness or behavior isn’t to your liking then you can adjust the resistors, for example raising R49 to 2M2 and R50/51 to 4k7.

Just be aware that if the combined resistance of R50 and R51 approaches around 10-12k, the LEDs will stop flashing. So if you’re already at 4k7 for both, then focus on raising R49.

We have tested it with red diffused LEDs, the type listed in the Mouser parts spreadsheet. Other colors and types may need different values for R49-51 or may not work at all. If you do want to try a different color, make sure to use the same color and type of LED for both. The current-limiting resistor and parallel resistor are shared between the two, so there is no way to adjust the current of just one LED.

Disabling the rate flash

The active LED will be continually flashing as long as the effect is powered, even in bypass mode. If you would rather use static LEDs that only indicate which knob is active, then you can do the following:

- Omit R49, R51 and Q13 (leave empty)
- Jumper the outer two pads of Q13 (E and C)
- Use 22k for R50

BUILD NOTES, CONT.

In this configuration, R50 becomes the current-limiting resistor that sets the brightness of the LEDs, so the value will depend on the type of LED used. If you find that the LEDs are too bright, increase the resistance, e.g. to 33k. If they are too dim then lower R50, e.g. to 15k.

As with the rate indicator, the LEDs share the same current-limiting resistor, so make sure to use the same type of LED for both or else one will likely be significantly brighter than the other.

Part variations

The Uni-Vibe circuit appeared under several brand names that all had minor variations, and even the official Uni-Vibe service manual's schematic differs from many of their own production units.

The Straylight's parts list is based on the parts that were most commonly used throughout production, and represents the generally-agreed-upon configuration from the DIY community.

We've attempted to compile all the official part variations we could find, but this is just a point of reference in case you're curious, or if you noticed a different value in a different DIY project. We strongly recommend using the default parts list.

- **R4 and R5** are sometimes 1M (usually 1M2). Likely changed due to the characteristics of different transistors used throughout production for Q1-3, but may just be due to parts availability.
- **R10** is sometimes 3k (usually 3k3) and **R11** is sometimes 1k (usually 1k2). Likely changed due to the characteristics of different transistors used throughout production for Q1-3, but may just be due to parts availability.
- **R14** is sometimes 100k (usually 47k). This adjusts the level of vibe-only mode to match it with chorus mode.
- **R39** is sometimes 3k (usually 3k3). This adjusts the bias point of the LFO slightly, but may have just been due to parts availability.
- **C19** and **C21** are sometimes 0.68uF (usually 1uF). This adjusts the speed range of the LFO slightly.
- **R45** is incorrectly listed on the factory schematic as 47k. It should be 4k7, which is the value used in every original unit and variant that we have seen.
- **R46** is usually 150R, either with a 500R trimmer or directly connected to ground. 68R allows for more of a gain range adjustment and you can dial in the original resistance with the trimmer. You can also use 47R or 100R.
- **R52** and **R53** are often 4k7 and sometimes 1k8, 2k or 2k2. These resistors limit the maximum speed of the LFO, and so it's recommended to use a lower value. In our testing, 2k2 worked well.

Enclosure size

This project was designed for the **Hammond 1590BBS** enclosure, which has the same height as the 125B or 1590N1. If you don't use the Hammond brand, be careful—not all 1590BBS enclosures are the same. For example, Love My Switches sells two different types, and the [CNC Pro](#) version is correct while the standard one is too short.

BUILD NOTES, CONT.

The 1590BB2 seems like a close equivalent, but it's about 4mm shorter in depth. The light shield sits high enough that it will not fit. The capacitors on the footswitch PCB would also create clearance problems if the enclosure is any shallower.

The 1590C has almost the same dimensions around the base, but due to the increased height and the draft angle of the walls, the dimensions at the bottom of the enclosure are a bit too small and the PCB won't fit.

Lamp lifespan

Current-production lamps have a rated lifespan of between 10,000 and 20,000 hours. The constant pulse of the LFO reduces this lifespan. It's strongly recommended to keep the pedal disconnected from power when not in use, which will lengthen the working lifespan by years if not decades. Alternately, you can engage the Cancel switch when not in use, which will have the same effect.

Either way, though, it's important to be aware that the lamp is the shortest-lifespan component in the circuit. It's not fragile by any means, but just keep it in the back of your mind that if the phasing stops working at any point, that's the first thing to check.

SCHEMATIC

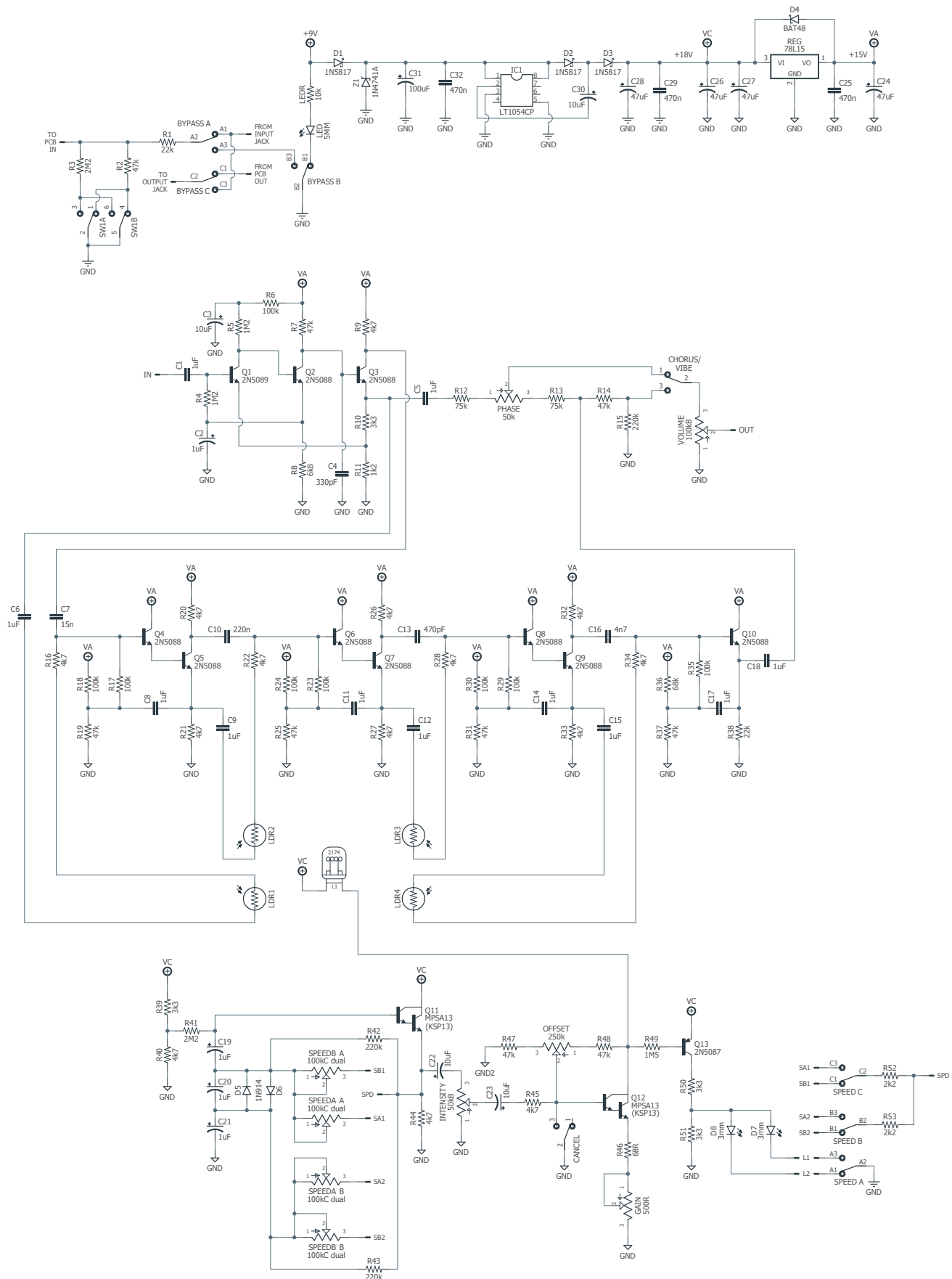

DRILL TEMPLATE

Cut out this drill template, fold the edges and tape it to the enclosure. Before drilling, it's recommended to first use a center punch for each of the holes to help guide the drill bit.

Ensure that this template is printed at 100% or "Actual Size". You can double-check this by measuring the scale on the printed page.

Top jack layout assumes the use of closed-frame jacks like the [Switchcraft 111X](#). If you'd rather use open-frame jacks, please refer to the Open-Frame Jack Drill Template for the top side.

LED hole drill size assumes the use of a [5mm LED bezel](#), available from several parts suppliers. Adjust size accordingly if using something different, such as a 3mm bezel, a plastic bezel, or just a plain LED.

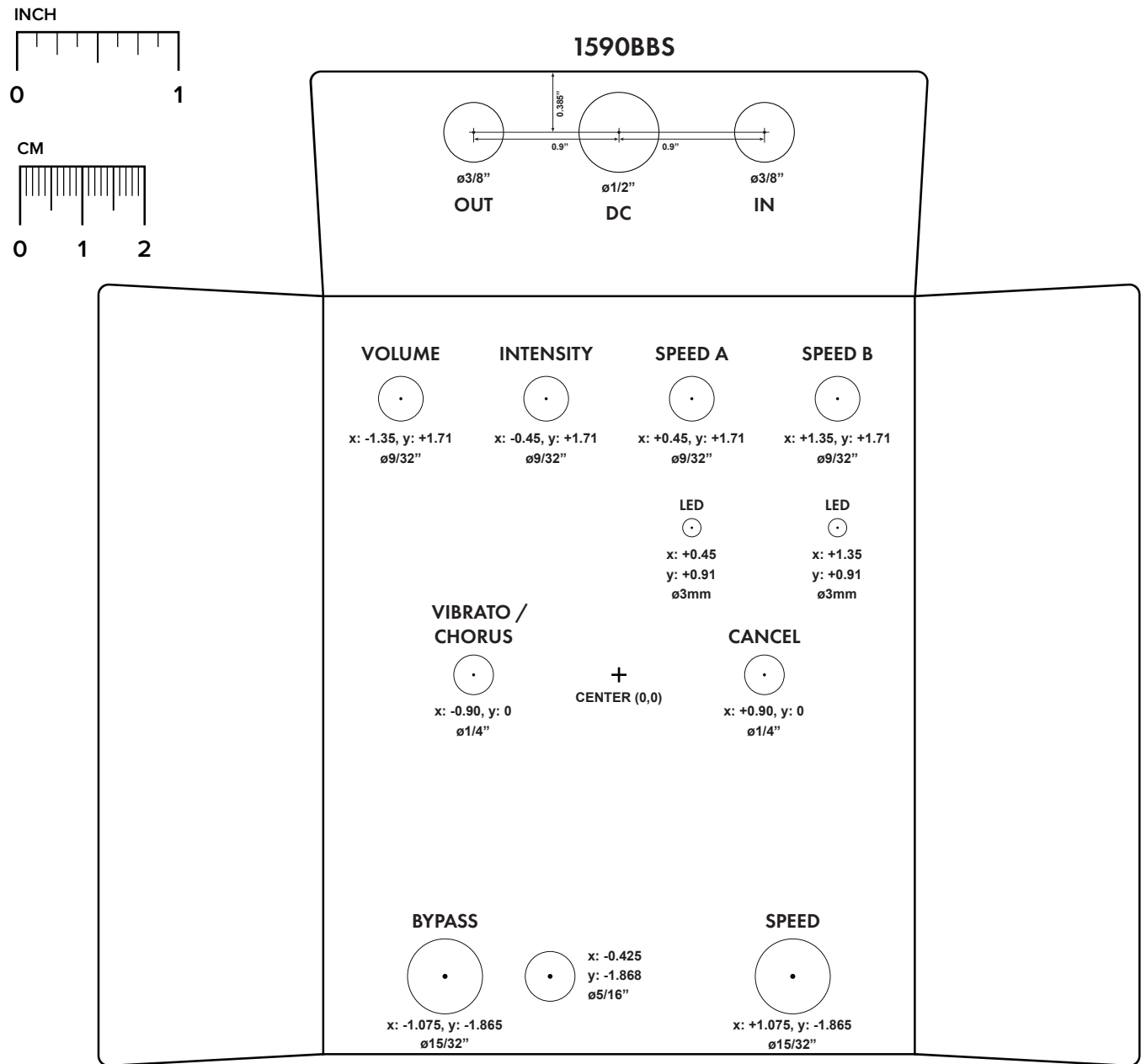

ENCLOSURE LAYOUT

Enclosure is shown without jacks. See next page for jack layout and wiring.

Note: The upper pads for the dual-gang gain potentiometers appear to be cut in half. **This is intentional!** These are called *plated half-holes* or *castellated holes*, and they are used so that the PCB can lay flat across the pots instead of angling upward for the dual pot.

Solder them like you would if they were normal pads, but bend the upper pins forward slightly so they make contact with the edge of the pads. The lower pins provide the support, so there will be no stress on the upper pins.

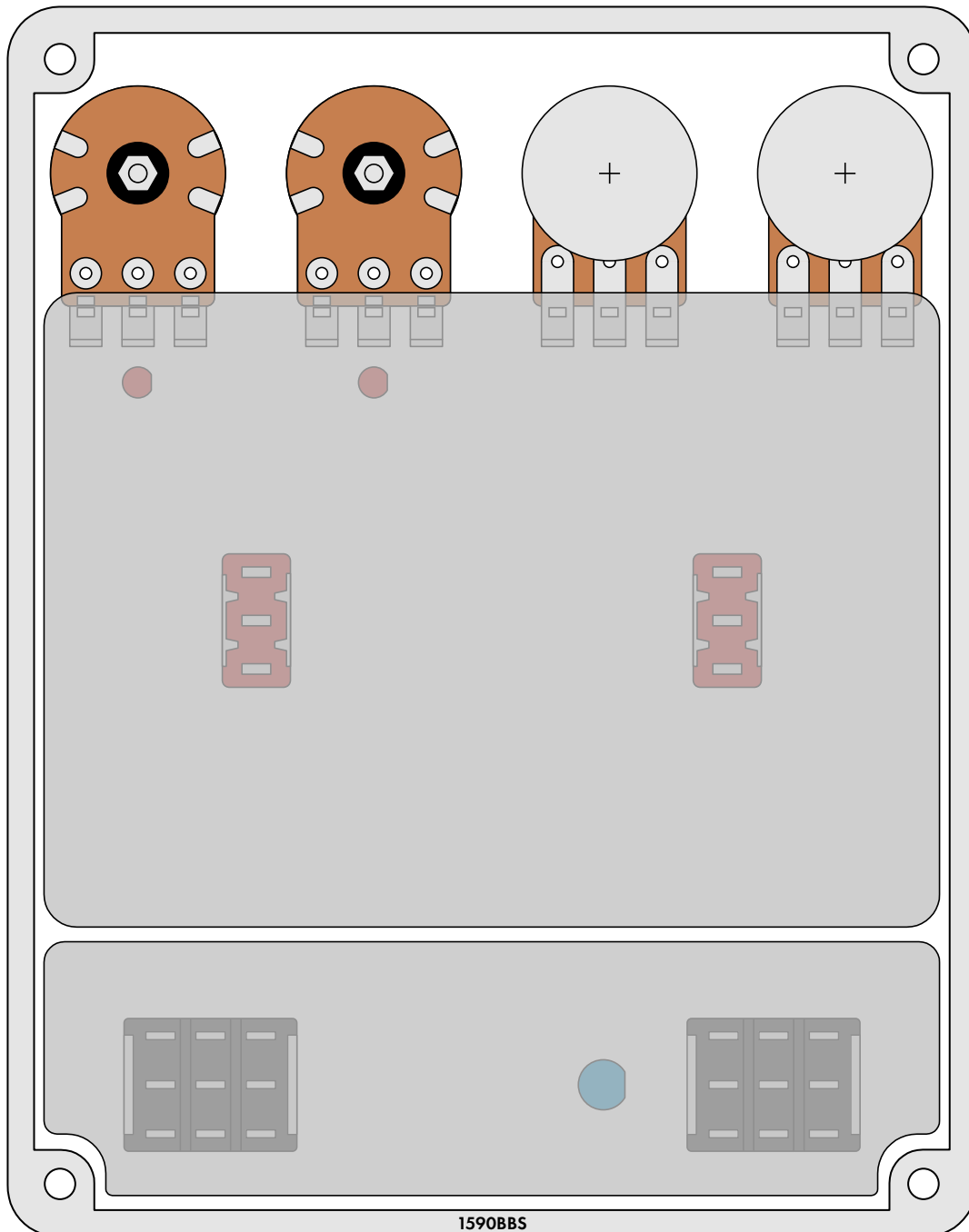

WIRING DIAGRAM

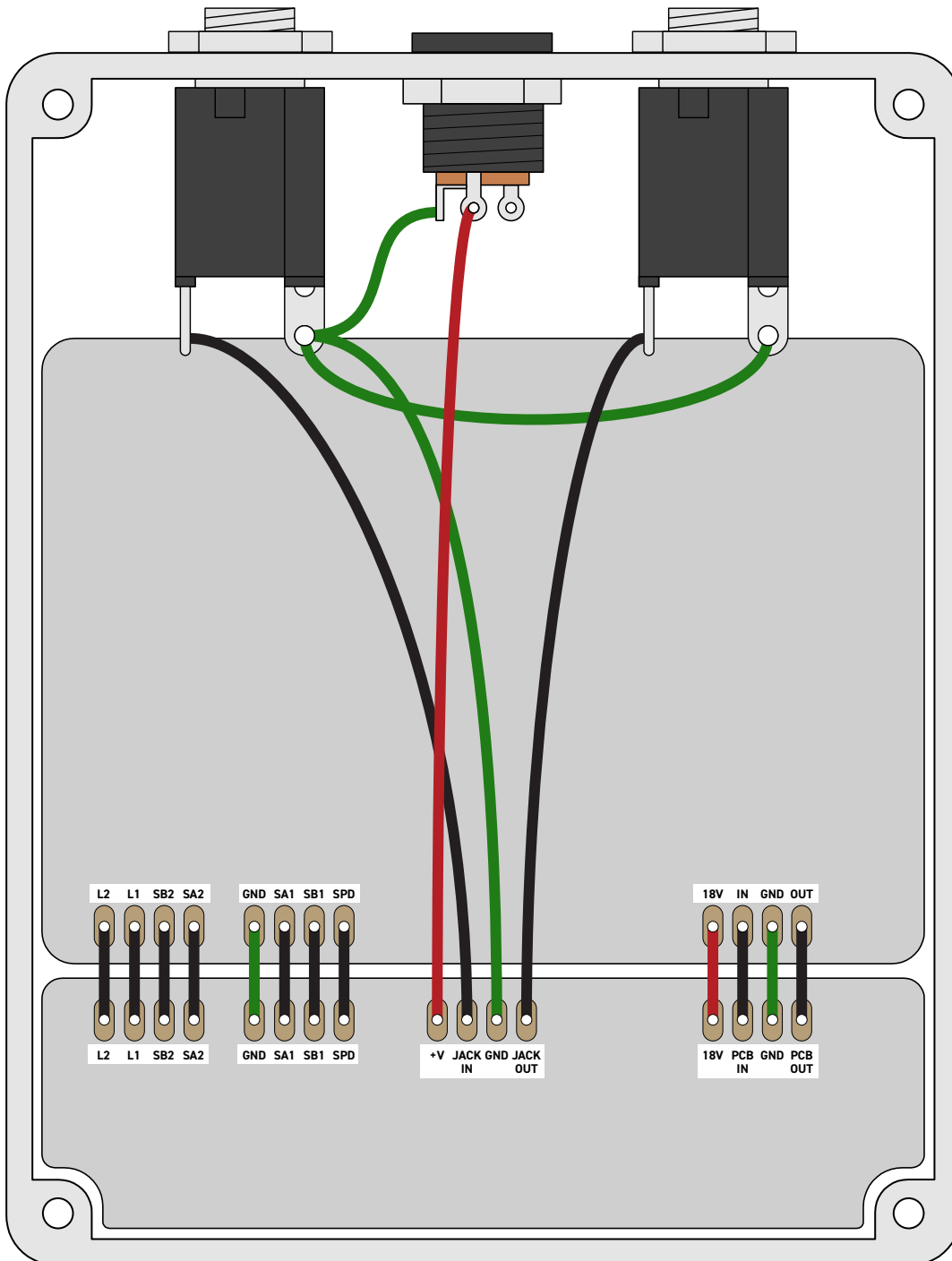

LICENSE & USAGE

Uni-Vibe is a registered trademark of Dunlop Manufacturing, Inc.

No direct support is offered for these projects beyond the provided documentation. It's assumed that you have at least some experience building pedals before starting one of these. Replacements and refunds cannot be offered unless it can be shown that the circuit or documentation are in error.

All of these circuits have been tested in good faith in their base configurations. However, not all the modifications or variations have necessarily been tested. These are offered only as suggestions based on the experience and opinions of others.

Projects may be used for commercial endeavors in any quantity unless specifically noted. No attribution is necessary, though a link back is always greatly appreciated. The only usage restrictions are that **(1) you cannot resell the PCB as part of a kit without prior arrangement, and (2) you cannot “goop” the circuit, scratch off the screenprint, or otherwise obfuscate the circuit to disguise its source.** (In other words: you don't have to go out of your way to advertise the fact that you use these PCBs, but please don't go out of your way to hide it. The guitar effects industry needs more transparency, not less!)

DOCUMENT REVISIONS

1.0.1 (2024-07-08)

- Corrected drill template. The footswitches and LED were positioned too high.
- Changed recommended value of R50-R51.
- Added note about enclosure size.

1.0.0 (2024-07-04)

Initial release.