

Solstice Distortion

Marshall Shredmaster

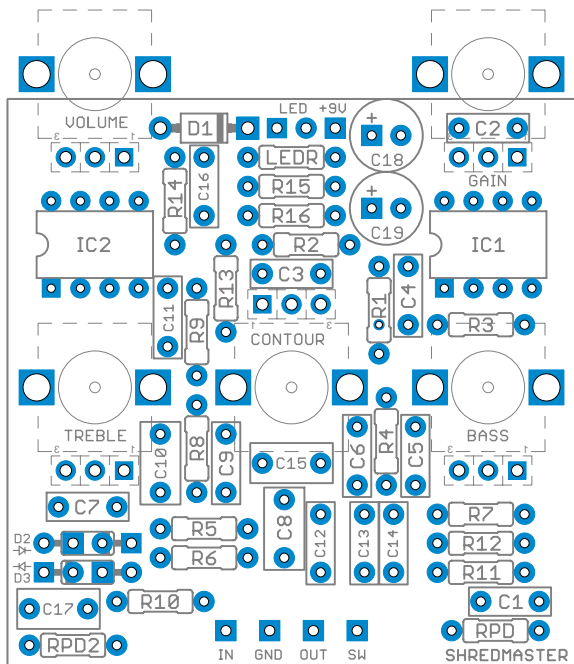

Overview



The Solstice Distortion project is a clone of the Marshall Shredmaster. First available in 1991, the Shredmaster was released at the same time as the Drivemaster (Guv'nor) and Bluesbreaker pedals.

The Shredmaster has a lot in common with the Drivemaster, and in fact the first half of both circuits are nearly identical. However, the Shredmaster has an additional gain stage and a very different tone section (even though the three tone knobs appear to be the same on the outside). The Shredmaster is probably most noted for being the favored distortion pedal of Jonny Greenwood from Radiohead and Kevin Shields of My Bloody Valentine.

Despite the name "Shredmaster", the pedal is not a saturated, high-gain metal monster like the Boss Metal Zone. However, it does a great job covering the spectrum between heavy blues and hard rock with fantastic tweakability.

Controls & Usage

The Shredmaster controls are pretty fancy for an overdrive:

- **Gain** controls the amount of gain from the op amp that is fed into the diode clipping stage.
- **Bass, Contour** (mids) and **Treble** act as a 3-band tone control, allowing for very flexible tone shaping.
- **Volume** controls the overall output.

Modifications & Experimentation

This is a pretty tight control layout, so no switch mods for this one. Extra pads have been provided so you can stack diodes if you'd like, but that's about it.

Be aware that due to the 5-knob layout, this project uses 9mm PCB-mounted pots (widely available from Small Bear, Tayda, etc). If you use standard 16mm pots, you'll have to wire them off-board and it may be really tight.

Notes about the original schematic

There are a lot of different Shredmaster schematics out there, and many of them are wildly different from each other, but it didn't seem like many of them were backed by actual traces of actual units. After comparing them all, the most authoritative one was the Brazilian [Guero PDF](#) project, which also correlated with another account from someone who has an original. The only difference in my project is that the Guero includes the original unit's switching system (around C4 and R3), which can be simplified down to one resistor and one capacitor in a true-bypass setup.

Parts

Resistors

| | |
|------|------------------|
| R1 | 1M |
| R2 | 3k3 |
| R3 | 8k2 |
| R4 | 680k |
| R5 | 10k |
| R6 | 6k8 |
| R7 | 1k |
| R8 | 47k ¹ |
| R9 | 220k |
| R10 | 100R |
| R11 | 33k |
| R12 | 33k |
| R13 | 100k |
| R14 | 100k |
| R15 | 47k |
| R16 | 47k |
| RPD | 1M to 2M2 |
| RPD2 | 1M ² |
| LEDR | 4k7 |

Capacitors

| | |
|-----|------------------|
| C1 | 10n |
| C2 | 100pF |
| C3 | 47n |
| C4 | 39n ³ |
| C5 | 47pF |
| C6 | 100n |
| C7 | 22n |
| C8 | 220n |
| C9 | 22n |
| C10 | 220n |
| C11 | 2n2 |
| C12 | 100n |
| C13 | 47n |
| C14 | 1n |
| C15 | 220n |
| C16 | 1n ⁴ |
| C17 | 220n |
| C18 | 47uF |
| C19 | 10uF |

Semiconductors

| | |
|----------|---------|
| IC1, IC2 | TL072 |
| D1 | 1N4002 |
| D2, D3 | 1N914 |
| LED | 5mm LED |

Potentiometers ⁵

| | |
|---------|-------------------|
| Gain | 100k Ω 9mm |
| Bass | 100k Ω 9mm |
| Contour | 100k Ω 9mm |
| Treble | 25k Ω 9mm |
| Volume | 100k Ω 9mm |

¹ Some schematics list R8 as **39k**. It makes very little difference, but **47k** is most likely the correct value.

² **Optional**. This is a pull-down resistor on the output. It's used in the original and may help with switch popping.

³ Depending on the schematic, you may see **220n** or **68n** here. The original has a capacitor, two resistors and another capacitor in series, with the junction between the resistors being grounded when the unit is in bypass. In a true-bypass arrangement, this can be reduced down to one resistor and one capacitor, so R3 is **8k2** and C4 is around 40n (68n + 100n in series), or **39n** as the nearest common value. But I tested it with all the different values and couldn't hear much of any difference. It's very early on in the circuit and a lot of tone filtering happens later, so even though it's a pretty wide swing in values, the bass content isn't really affected. There's still more than enough bass available in the tone section either way.

⁴ Many people feel that the original **1n** capacitor cuts too much treble, and that it sounds a lot better lowered to 470pF, 220pF or 100pF. (In fact, the "Hyde" side of the Visual Sound Jekyll & Hyde pedal, which is a Shredmaster, adds a "Sharp/Blunt" switch that switches this capacitor between 1n and 100pF.) I tested a few different values here and personally preferred **470pF** or **820pF**—lower than that and it was too bright.

⁵ This project uses **Alpha 9mm PCB-mount pots**, widely available from Small Bear, Mouser, Tayda, Mammoth and many other places. The standard 16mm pots will not fit easily!

Additional Part Notes

- Capacitors are shown in nanofarads (n or nF) where appropriate. 1000n = 1uF. Many online suppliers do not use nanofarads, so you'll often have to look for 0.047uF instead of 47n, 0.0056uF instead of 5n6, etc.
- The PCB layout assumes the use of film capacitors with 5mm lead spacing for all values 1nF through 470nF. I prefer [EPCOS box film](#) or [Panasonic ECQ-B/V-series](#).

Schematic

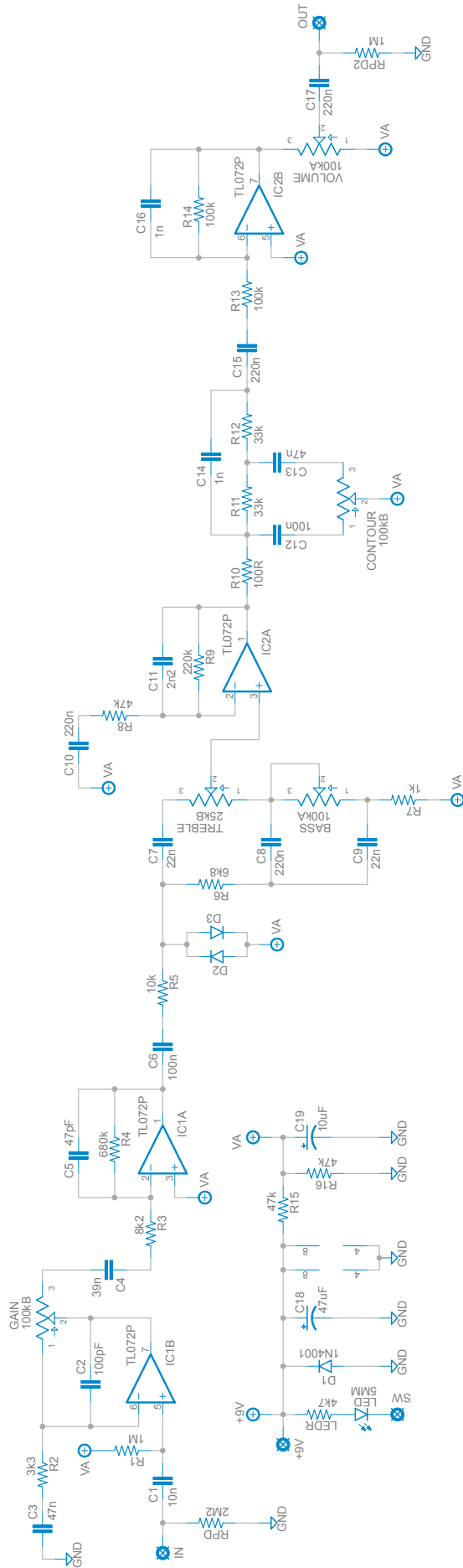

General Build Instructions

These are general guidelines and explanations for all Aion Electronics DIY projects, so be aware that not everything described below may apply to this particular project.

Build Order

When putting together the PCB, it's recommended that you do not yet solder any of the enclosure-mounted control components (pots and switches) to the board. Instead, follow this build order:

1. Attach the **audio jacks**, **DC jack** and **footswitch** to the enclosure.
2. Firmly attach the **pots** and **switches** to the enclosure, taking care that they are aligned and straight.
3. Push the **LED**¹ into the hole in the enclosure with the leads sticking straight up, ensuring that the flat side is oriented according to the silkscreen on the PCB.
4. Fit the **PCB** onto all the control components, including the leads of the LED. If it doesn't fit, or if you need to bend things more than you think you should, double-check the alignment of the pots and switches.
5. Once you feel good about everything, **solder them from the top**² as the last step before wiring. This way there is no stress on the solder joints from slight misalignments that do not fit the drilled holes. You can still take it out easily if the build needs to be debugged, but now the PCB is "custom-fit" to that particular enclosure.
6. Wire everything according to the wiring diagram on the last page.

¹ **For the LED:** You can use a bezel if you'd like, but generally it's easier just to drill the proper size of hole and push the LED through so it fits snugly. If you solder it directly to the PCB, it'll stay put even if the hole is slightly too big. Make absolutely sure the LED is oriented correctly (the flat side matches the silk screen) before soldering, as it'll be a pain to fix later! After it's soldered, clip off the excess length of the leads.

² **Note on soldering the toggle switch(es):** It will require a good amount of solder to fill the pads. Try to be as quick as possible to avoid melting the lugs, and be prepared to feed a lot of solder as soon as the solder starts to melt. I recommend waiting 20-30 seconds between soldering each lug to give it time to cool down.

"RPD" and "LEDR" resistors

The resistors marked "RPD" and "LEDR" are generally not original to the circuit and can be adjusted to preference. "RPD" is the pulldown resistor to help tame true-bypass popping, while "LEDR" controls the brightness of the LED. I generally use 2.2M for the pulldown resistor and 4.7k for the LED resistor.

Sockets

Since double-sided boards can be very frustrating to desolder, especially components with more than 2 leads, it is recommended to use sockets for all transistors and ICs. It may save you a lot of headaches later on.

Drilling & Placement

Print this page and have an adult cut out the drilling template below for you. Tape it to the enclosure to secure it while drilling. Note that the holes are shown slightly smaller than they need to be, so drill out the holes as shown and then step up until they are the correct size for the components.

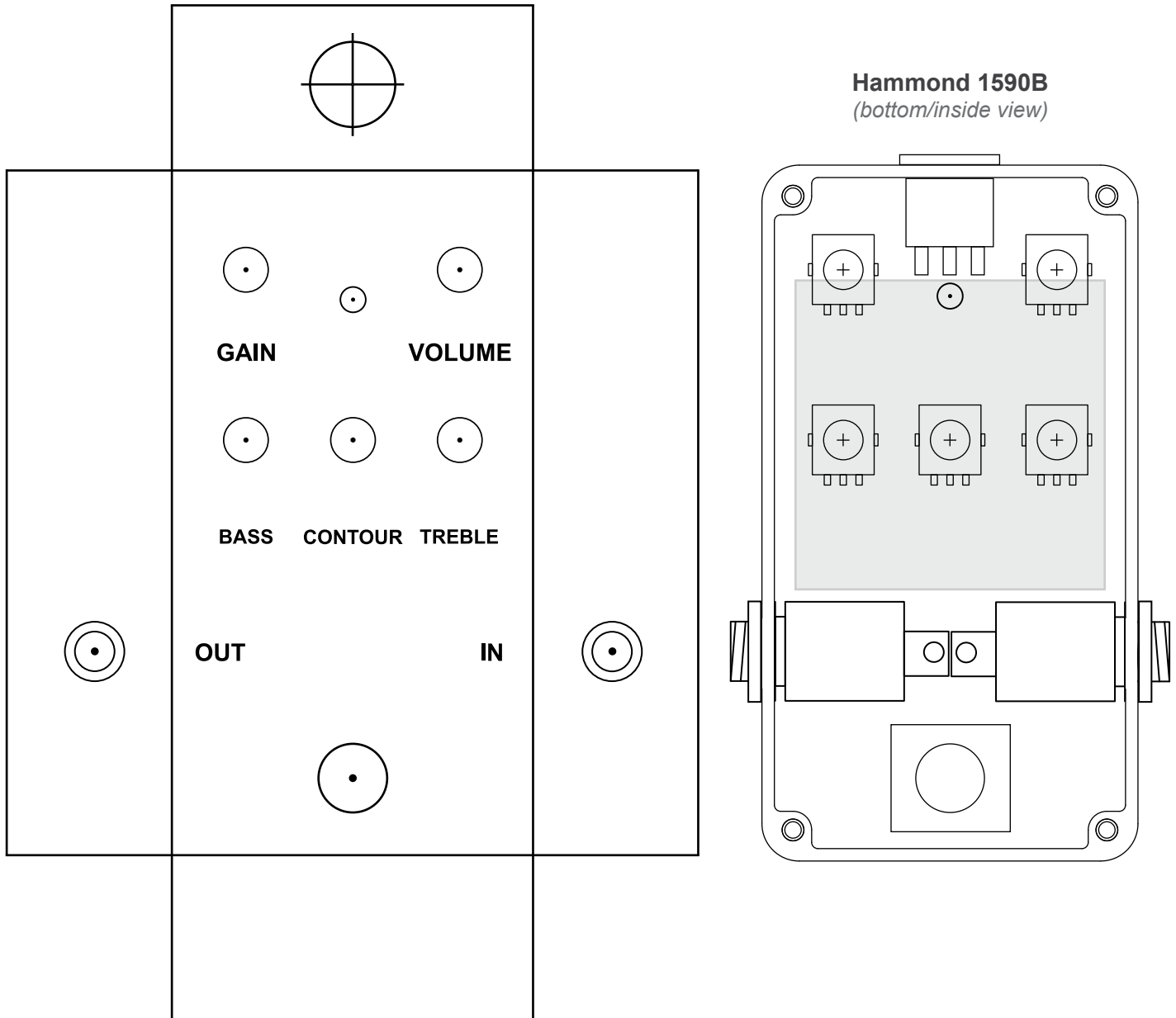

Parts Used

- [Switchcraft #111A](#) enclosed jacks
- [Kobiconn-style DC jack](#) with internal nut

Standard Wiring Diagram

This diagram shows standard true-bypass wiring with a 3PDT switch. When the switch is off, the input of the circuit is grounded and the input jack is connected directly to the output jack.

The **SW** pad is the cathode connection for the LED. This will connect to ground to turn it on when the switch is on. Usage of the on-board LED connection is not required if you have specific placement needs for your enclosure, but's incredibly convenient.

The wiring diagram also makes use of **star grounding** principles where all of the grounds connect to a single ground point (in this case the sleeve of the input jack). This is best practice to avoid added noise caused by improper grounding. The sleeve of the output jack is unconnected.

If using a painted or powdercoated enclosure, **make sure both jacks have solid contact with bare aluminum** for grounding purposes. You may need to sand off some of the paint or powdercoat on the inside in order to make this happen.

Make sure to double-check the markings of the pads on the PCB for your particular project – they are not always in the order shown here!

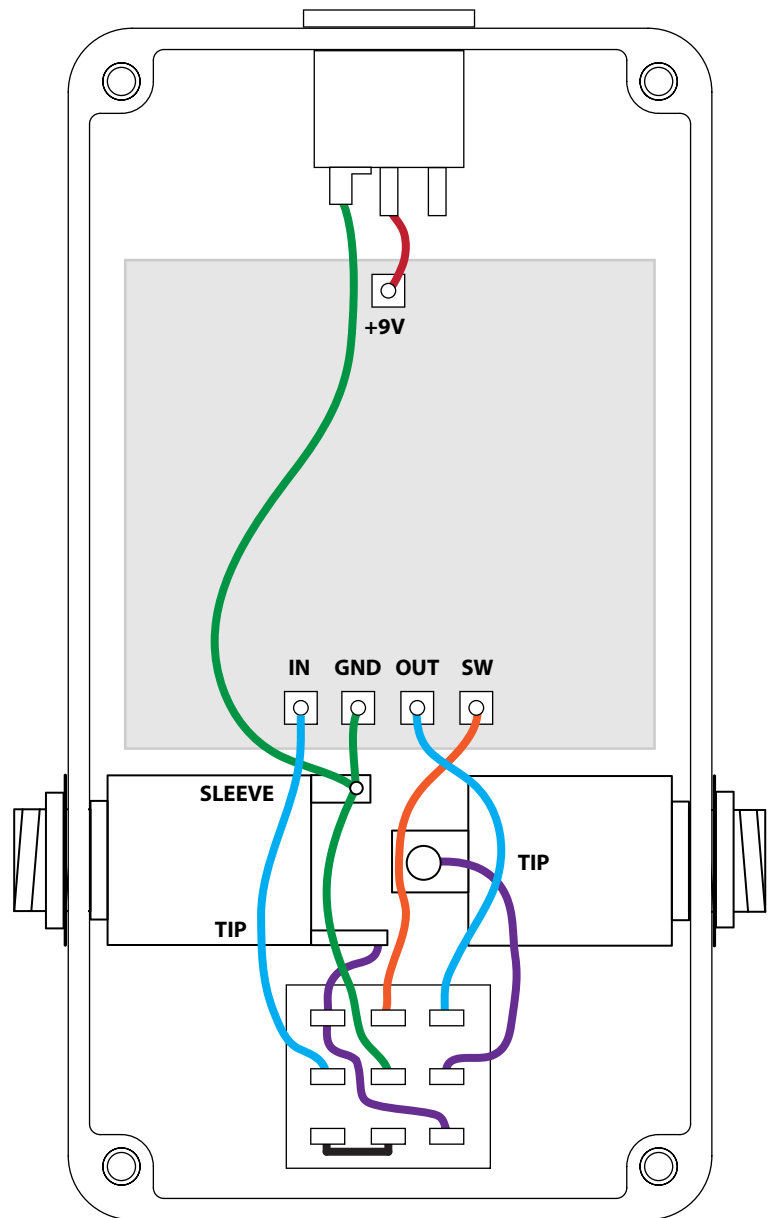

License / Usage

No direct support is offered for these PCBs beyond the provided documentation. It is assumed that you have at least some experience building pedals before starting one of these. Replacements and refunds will not be offered unless it can be shown that the circuit or documentation are in error. I have in good faith tested all of these circuits. However, I have not necessarily tested every listed modification or variation. These are offered only as suggestions based on the experience and opinions of others.

Projects may be used for commercial endeavors in any quantity unless specifically noted. No bulk pricing or discounting is offered. No attribution is necessary, though a link back is always greatly appreciated. The only usage restrictions are that **(1) you cannot resell the PCB as part of a kit, and (2) you cannot “goop” the circuit, scratch off the screenprint, or otherwise obfuscate the circuit to disguise its source.** (In other words: you don't have to go out of your way to advertise the fact that you use these PCBs, but please don't go out of your way to hide it. The guitar effects pedal industry needs more transparency, not less!)