

PROJECT NAME
PERSEID

BASED ON
Cornish BD-1

BUILD DIFFICULTY
■■■■□ Intermediate

EFFECT TYPE
Bass overdrive

DOCUMENT VERSION
1.0.0 (2026-07-03)

PROJECT SUMMARY

A vintage-inspired bass overdrive with germanium clipping and a 2-band Baxandall tone stack.

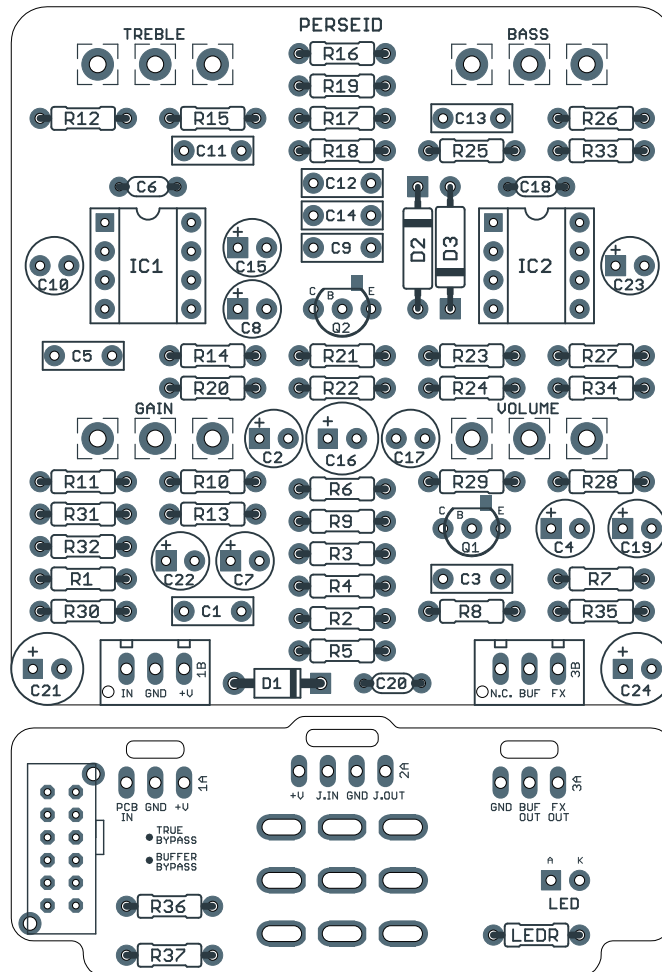

Actual size is 2.3" x 2.43" (main board) and 2.3" x 0.87" (bypass board).

TABLE OF CONTENTS

1	Project Overview	8	Drill Template
2	Introduction & Usage	9	Enclosure Layout
3-5	Parts List	10	Wiring Diagram
6	Build Notes	11	Licensing
7	Schematic	11	Document Revisions

INTRODUCTION

The Perseid Bass Drive is an adaptation of the Pete Cornish BD-1, a vintage-inspired bass overdrive with similarities to the [Cornish SS-3](#) and [MXR Distortion+](#). It was originally [traced by Aion FX in 2026](#).

Cornish pedals are best known for being extremely expensive. There are two reasons for this. First, the build quality and reliability is unmatched. Second, the mysterious nature of them, partially due to the fact that the circuit is obscured and partially because of the A-list of clients such as David Gilmour, Brian May and Pete Townshend.

The BD-1 was originally released in 2014, hot on the heels of the OC-1 and CC-1 the year before. To date, it's the only pedal from Cornish that is specifically designed for bass.

The first half of the circuit is adapted from the Distortion+ with a few value changes, which means it's also substantially similar to the SS-2 and SS-3. The main difference is larger coupling capacitors to retain the low-end frequencies.

This is followed by a 2-band Baxandall EQ, which is noteworthy for being driven by a transistor instead of an op-amp. The bass EQ has a center frequency of 30 Hz, which is significantly lower than bass controls on effects intended for guitar, and the treble EQ center frequency is 3 kHz.

The Perseid is a faithful reproduction of the BD-1 circuit, but with one major addition: an internal slide switch allowing the pedal to be used in true-bypass mode instead of buffered bypass. As with the Klon KTR, the buffered mode is "almost always better", but you can determine for yourself.

USAGE

The Perseid has four controls:

- **Gain** (labeled Sustain on the original unit) controls the gain of the op-amp stage that precedes the germanium clipping diodes.
- **Bass** allows the bass frequencies to be boosted or cut at 30 Hz, with neutral at 12:00.
- **Treble** allows the treble frequencies to be boosted or cut at 3 kHz, with neutral at 12:00.
- **Volume** is the overall output level of the effect.

PARTS LIST

This parts list is also available in a spreadsheet format which can be imported directly into Mouser for easy parts ordering. Mouser doesn't carry all the parts—notably potentiometers—so the second tab lists all the non-Mouser parts as well as sources for each.

[View parts list spreadsheet](#) →

PART	VALUE	TYPE	NOTES
R1	10M	Metal film resistor, 1/4W	
R2	1k	Metal film resistor, 1/4W	
R3	120k	Metal film resistor, 1/4W	
R4	120k	Metal film resistor, 1/4W	
R5	200k	Metal film resistor, 1/4W	
R6	7k5	Metal film resistor, 1/4W	
R7	10k	Metal film resistor, 1/4W	
R8	51R	Metal film resistor, 1/4W	
R9	1M	Metal film resistor, 1/4W	
R10	10k	Metal film resistor, 1/4W	
R11	1M	Metal film resistor, 1/4W	
R12	200k	Metal film resistor, 1/4W	
R13	510R	Metal film resistor, 1/4W	
R14	2k	Metal film resistor, 1/4W	
R15	5k1	Metal film resistor, 1/4W	
R16	5k6	Metal film resistor, 1/4W	
R17	4k7	Metal film resistor, 1/4W	
R18	4k7	Metal film resistor, 1/4W	
R19	39k	Metal film resistor, 1/4W	
R20	33k	Metal film resistor, 1/4W	
R21	150k	Metal film resistor, 1/4W	
R22	330R	Metal film resistor, 1/4W	
R23	1k8	Metal film resistor, 1/4W	
R24	5k6	Metal film resistor, 1/4W	
R25	5k1	Metal film resistor, 1/4W	
R26	33k	Metal film resistor, 1/4W	
R27	51R	Metal film resistor, 1/4W	
R28	4k3	Metal film resistor, 1/4W	
R29	51R	Metal film resistor, 1/4W	
R30	100R	Metal film resistor, 1/4W	
R31	150k	Metal film resistor, 1/4W	
R32	180k	Metal film resistor, 1/4W	

PARTS LIST, CONT.

PART	VALUE	TYPE	NOTES
R33	10k	Metal film resistor, 1/4W	
R34	10k	Metal film resistor, 1/4W	
R35	100R	Metal film resistor, 1/4W	
R36	91R	Metal film resistor, 1/4W	
R37	51k	Metal film resistor, 1/4W	
LEDR	10k	Metal film resistor, 1/4W	LED current-limiting resistor. Adjust value to change LED brightness.
C1	100n	Film capacitor, 7.2 x 2.5mm	
C2	4.7uF	Electrolytic capacitor, 4mm	
C3	1n	Film capacitor, 7.2 x 2.5mm	
C4	22uF	Electrolytic capacitor, 5mm	
C5	22n	Film capacitor, 7.2 x 2.5mm	
C6	220pF	MLCC capacitor, NP0/COG	
C7	10uF	Electrolytic capacitor, 5mm	
C8	10uF	Electrolytic capacitor, 5mm	
C9	10n	Film capacitor, 7.2 x 2.5mm	
C10	4.7uF bipolar	Electrolytic capacitor, 5mm, bipolar	
C11	10n	Film capacitor, 7.2 x 2.5mm	
C12	10n	Film capacitor, 7.2 x 2.5mm	
C13	100n	Film capacitor, 7.2 x 2.5mm	
C14	100n	Film capacitor, 7.2 x 2.5mm	
C15	10uF	Electrolytic capacitor, 5mm	
C16	100uF	Electrolytic capacitor, 6.3mm	
C17	4.7uF bipolar	Electrolytic capacitor, 5mm, bipolar	
C18	220pF	MLCC capacitor, NP0/COG	
C19	47uF	Electrolytic capacitor, 5mm	
C20	100n	MLCC capacitor, X7R	Power supply filter capacitor.
C21	220uF	Electrolytic capacitor, 6.3mm	Power supply filter capacitor.
C22	10uF	Electrolytic capacitor, 5mm	Reference voltage filter capacitor.
C23	22uF	Electrolytic capacitor, 5mm	Reference voltage filter capacitor.
C24	220uF	Electrolytic capacitor, 6.3mm	Power supply filter capacitor.
D1	1N5817	Schottky diode, DO-41	
D2	1N34A	Germanium diode	Part number is unimportant. Just about any germanium should work here. Can also use BAT46 Schottky diode.
D3	1N34A	Germanium diode	
Q1	BC549C	BJT transistor, NPN, TO-92	
Q2	BC549C	BJT transistor, NPN, TO-92	
IC1	TL071	Operational amplifier, single, DIP8	
IC1-S	DIP-8 socket	IC socket, DIP-8	

PARTS LIST, CONT.

PART	VALUE	TYPE	NOTES
IC2	TL071	Operational amplifier, single, DIP8	
IC2-S	DIP-8 socket	IC socket, DIP-8	
GAIN	50kC	16mm right-angle PCB mount pot	Reverse audio (reverse log) taper.
BASS	100kB	16mm right-angle PCB mount pot	Linear taper.
TREBLE	100kB	16mm right-angle PCB mount pot	Linear taper.
VOLUME	10kA	16mm right-angle PCB mount pot	Audio (log) taper.
TB-BUF	4PDT slide	Slide switch, 4PDT	E-Switch EG4208 (4mm lever) or EG4208A (6mm lever)
LED	5mm	LED, 5mm, red diffused	
IN	1/4" mono	1/4" phone jack, closed frame	Switchcraft 111X or equivalent.
OUT	1/4" mono	1/4" phone jack, closed frame	Switchcraft 111X or equivalent.
DC	2.1mm	DC jack, 2.1mm panel mount	Lumberg NEB/J 21 C or equivalent.
FSW	3PDT	Stomp switch, 3PDT	Available from Aion FX .
ENC	125B	Enclosure, die-cast aluminum	Can also use a Hammond 1590N1.

BUILD NOTES

Transistor selection

The original BD-1 uses BC549C transistors. You can substitute USA “E-B-C” transistors such as the 2N5088 or 2N5089. These will operate identically to the BC549C, but note that the pinout is reversed, so they will need to be rotated 180 degrees from the silkscreen outline on the PCB.

Bypassing the true bypass / buffer switch

The E-Switch EG4208 slide switch used for the true bypass/buffer selector is available from Mouser Electronics but may not be accessible to everyone. If you are unable to obtain it, you can hard-wire the switch to either true bypass mode or buffered mode by soldering jumpers to the switch pads.

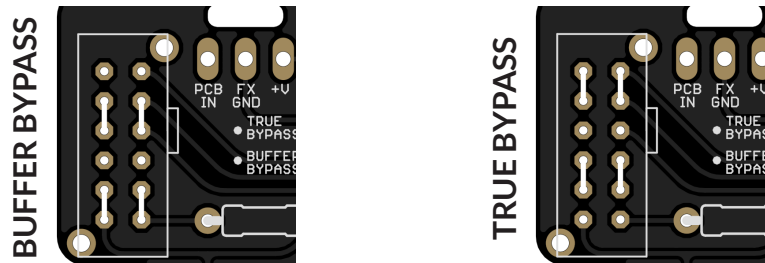

SCHEMATIC

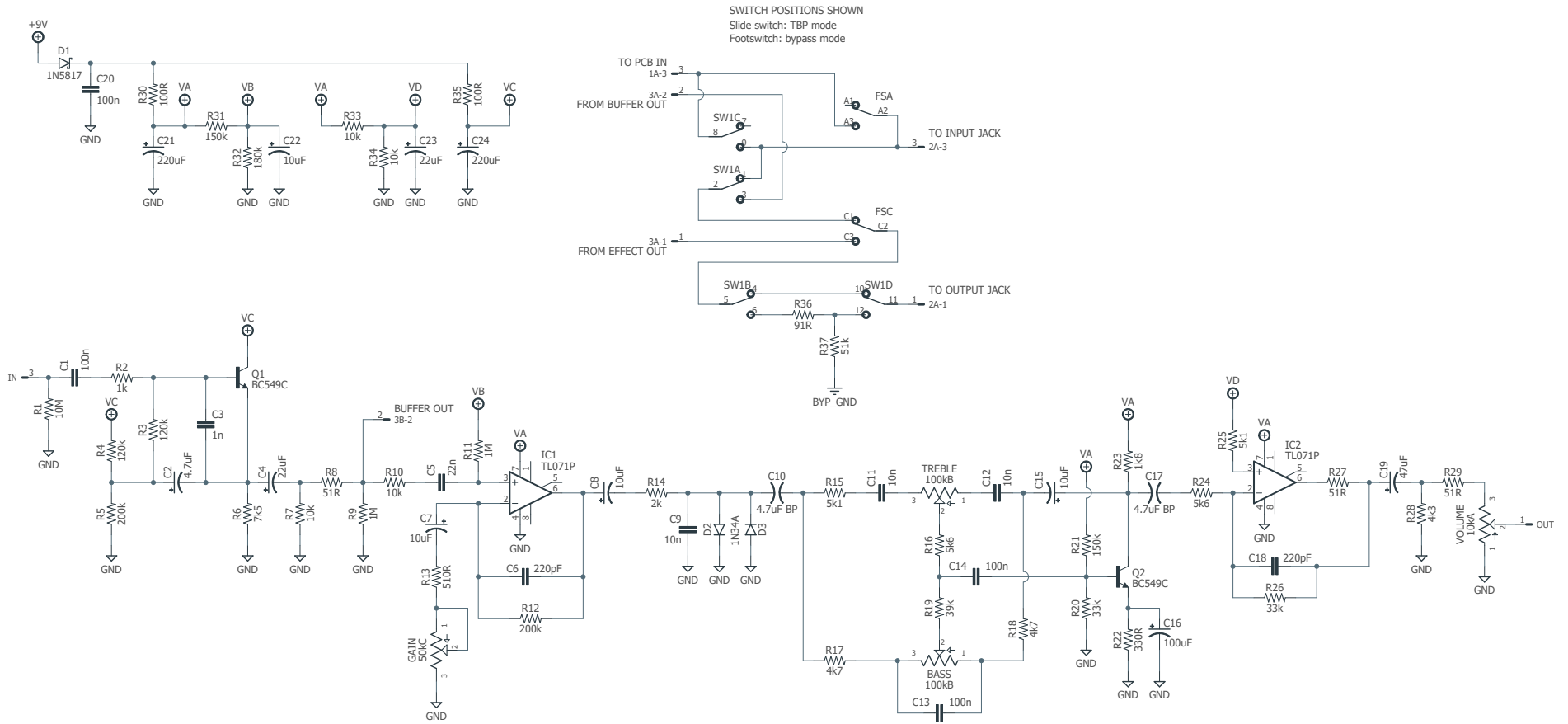

DRILL TEMPLATE

Cut out this drill template, fold the edges and tape it to the enclosure. Before drilling, it's recommended to first use a center punch for each of the holes to help guide the drill bit.

Ensure that this template is printed at 100% or "Actual Size". You can double-check this by measuring the scale on the printed page.

Top jack layout assumes the use of closed-frame jacks like the [Switchcraft 111X](#). If you'd rather use open-frame jacks, please refer to the [Open-Frame Jack Drill Template](#) for the top side.

LED hole drill size assumes the use of a [5mm LED bezel](#), available from several parts suppliers. Adjust size accordingly if using something different, such as a 3mm bezel, a plastic bezel, or just a plain LED.

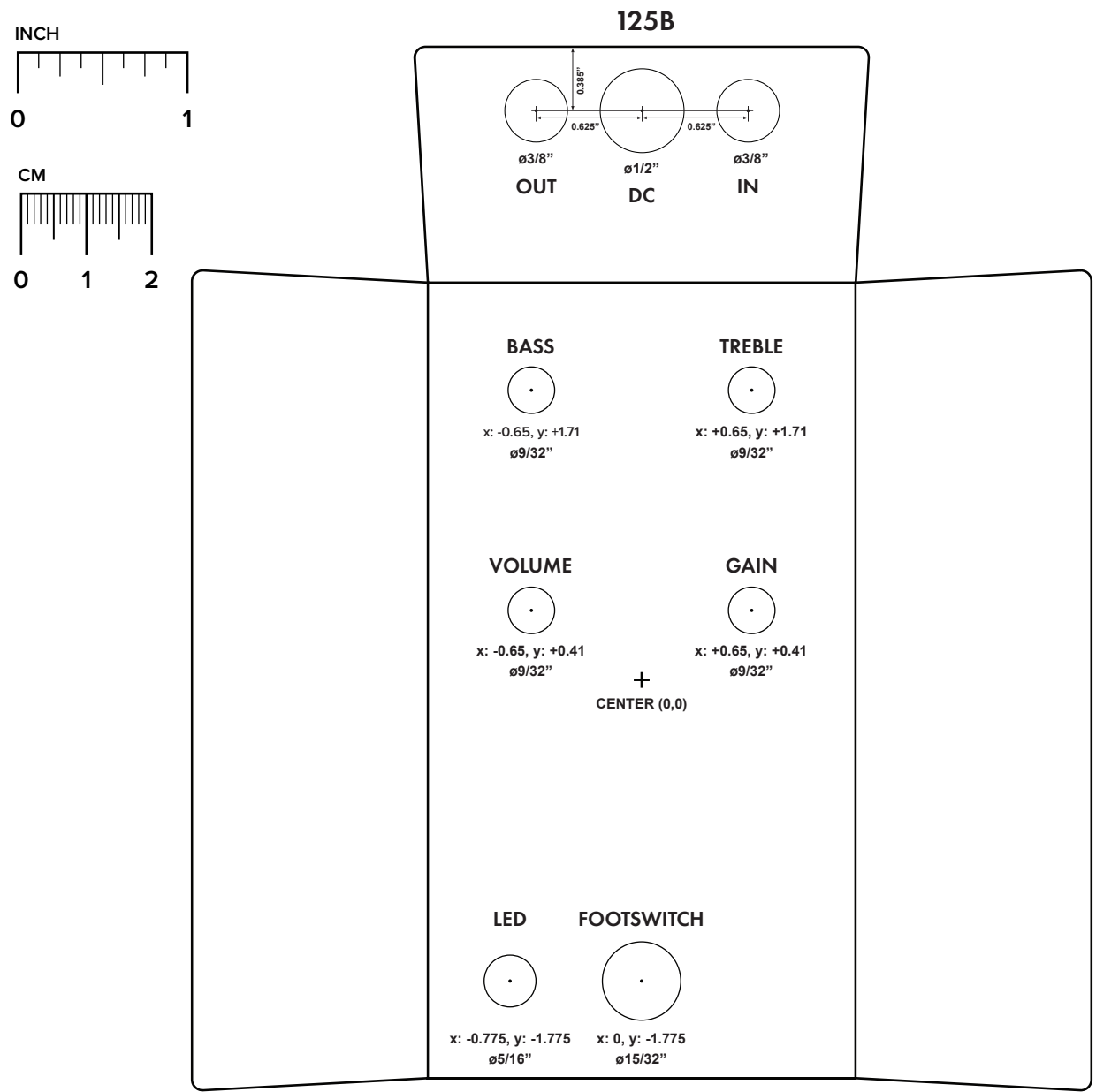

ENCLOSURE LAYOUT

Enclosure is shown without jacks. See next page for jack layout and wiring.

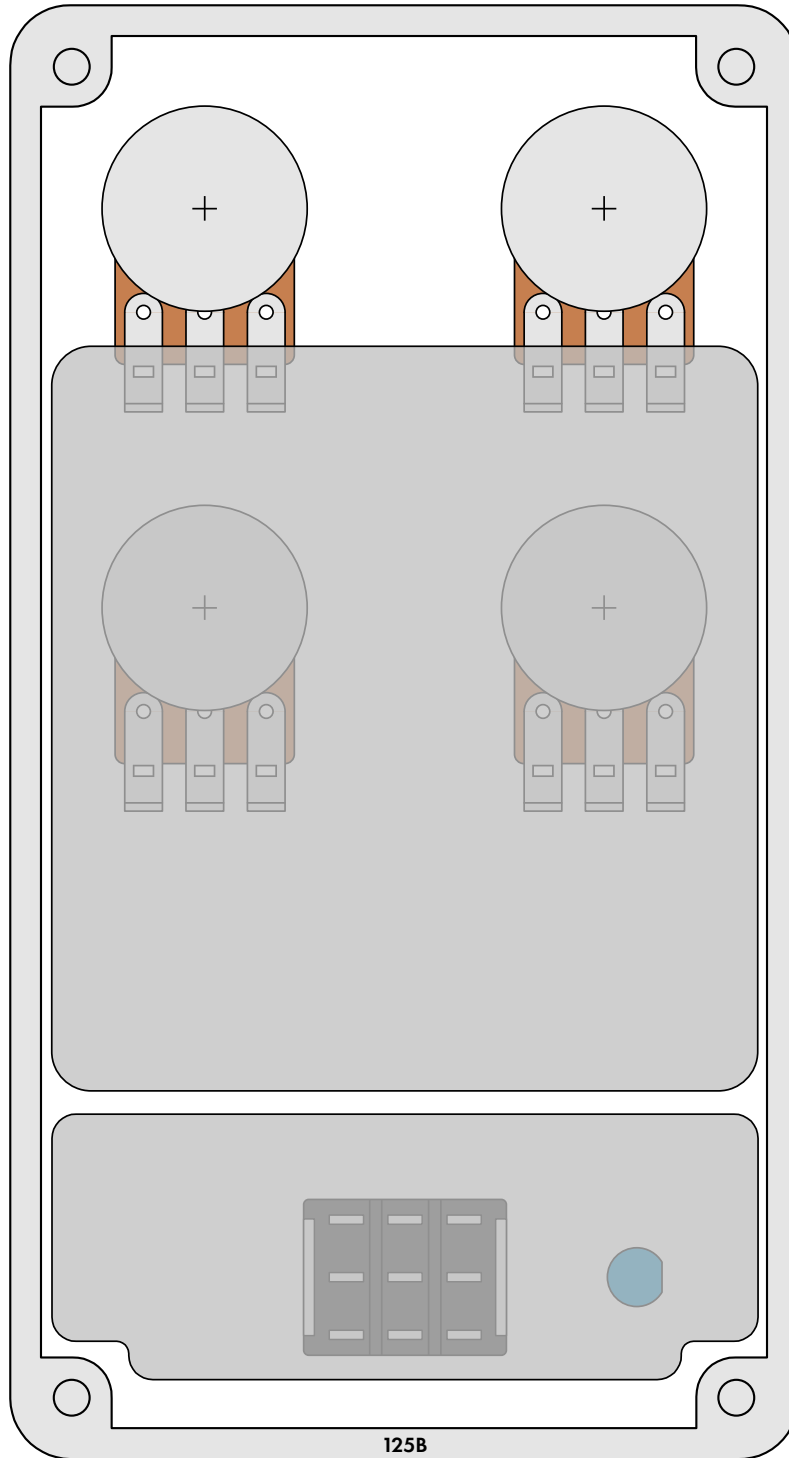

WIRING DIAGRAM

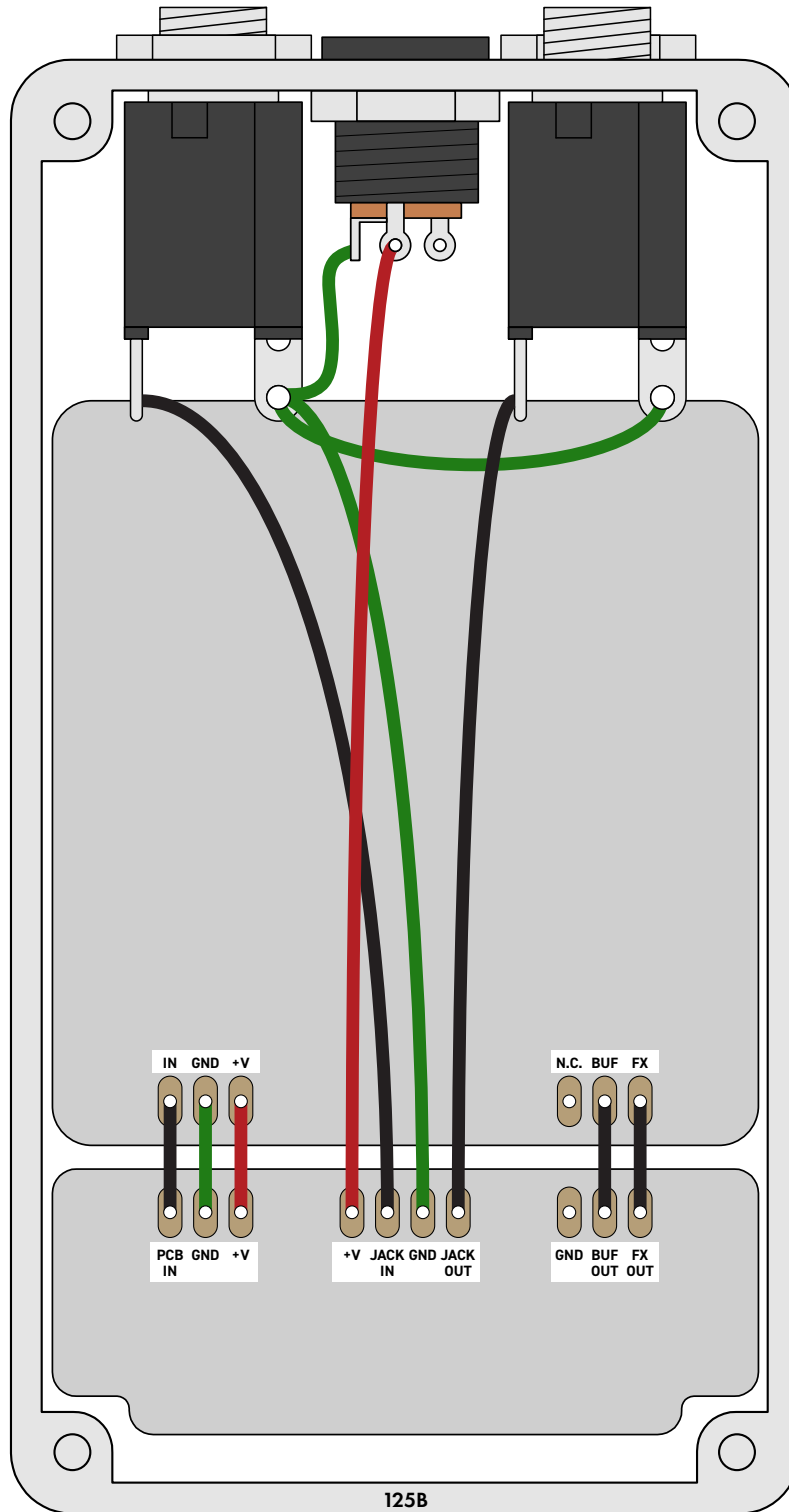

LICENSE & USAGE

No direct support is offered for these projects beyond the provided documentation. It's assumed that you have at least some experience building pedals before starting one of these. Replacements and refunds cannot be offered unless it can be shown that the circuit or documentation are in error.

All of these circuits have been tested in good faith in their base configurations. However, not all the modifications or variations have necessarily been tested. These are offered only as suggestions based on the experience and opinions of others.

Projects may be used for commercial endeavors in any quantity unless specifically noted. No attribution is necessary, though a link back is always greatly appreciated. The only usage restrictions are that **(1) you cannot resell the PCB as part of a kit without prior arrangement, and (2) you cannot "goop" the circuit, scratch off the screenprint, or otherwise obfuscate the circuit to disguise its source.** (In other words: you don't have to go out of your way to advertise the fact that you use these PCBs, but please don't go out of your way to hide it. The guitar effects industry needs more transparency, not less!)

DOCUMENT REVISIONS

1.0.0 (2026-07-03)

Initial release.