

PROJECT NAME

MALACANDRA



BASED ON

Xotic AC/RC Booster

BUILD DIFFICULTY



EFFECT TYPE

Boost / Overdrive

DOCUMENT VERSION

2.0.0 (2020-06-26)

PROJECT SUMMARY

A flexible drive pedal that can go from clean volume boost to smooth overdrive. Includes a 2-band tone stack for treble & bass.

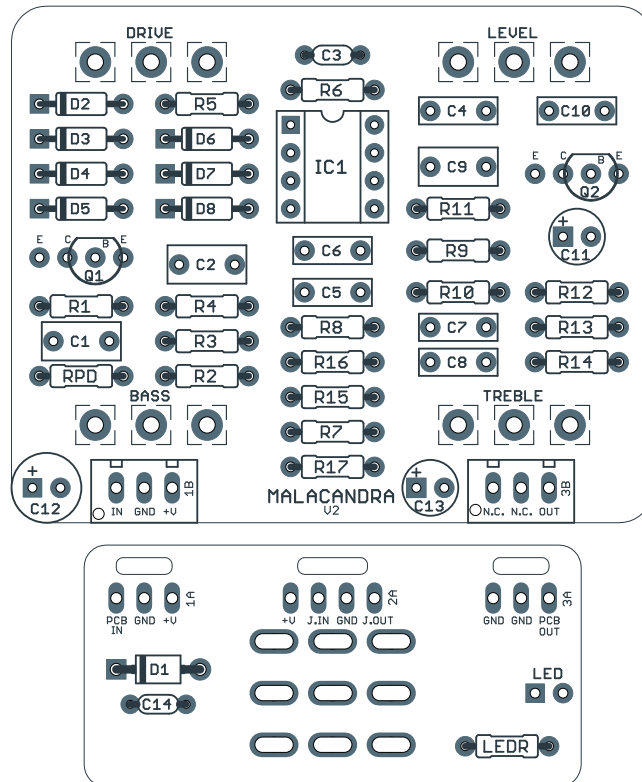

Actual size is 2.3" x 1.86" (main board) and 2.3" x 0.86" (bypass board).

TABLE OF CONTENTS

1	Project Overview	7	Drill Template
2	Introduction & Usage	8	Enclosure Layout
3-4	Parts List	9	Wiring Diagram
5	Build Notes	10	Licensing
6	Schematic	10	Document Revisions

INTRODUCTION

The Malacandra Boost / Overdrive is a recreation of the Xotic AC Booster and RC Booster, two nearly identical pedals that feature a two-band EQ for independent control of bass & treble frequencies. The result is a flexible tone machine that lets you go from a clean volume boost to a thick overdrive.

Looking at the schematic for the AC & RC Booster circuits, it's very similar to a Tube Screamer, starting with an input buffer and an op-amp feedback diode clipping stage. The two major topological differences are that the AC/RC circuit uses an inverting op-amp stage for clipping (the TS is non-inverting), and the Tube Screamer tone control has been replaced by a Baxandall stage with bass and treble.

The BB Preamp (also available from Aion FX, called the [Perelandra](#)) is a similar circuit. The main difference is that it retains the Tube Screamer's tone control section, hard-wired at the 9:00 position.

Version 2 of the Malacandra has been updated slightly based on direct traces of the current-production AC Booster and RC Booster as well as the Bass RC Booster. With the Malacandra PCB, you can build any of the three circuits by changing a few parts. Instructions are provided for each variant.

USAGE

The Malacandra has four controls:

- **Gain** controls the amount of gain from the op amp that is fed through the feedback clipping diodes.
- **Treble** is one half of the Baxandall tone control, allowing you to boost or cut high frequencies.
- **Bass** is the other half of the Baxandall tone control, allowing you to boost or cut low frequencies.
- **Level** sets the overall output of the effect.

PARTS LIST

This parts list is also available in a spreadsheet format which can be imported directly into Mouser for easy parts ordering. Mouser doesn't carry all the parts—notably potentiometers—so the second tab lists all the non-Mouser parts as well as sources for each.

[View parts list spreadsheet](#) →

PART	VALUE	TYPE	NOTES
R1	10k	Metal film resistor, 1/4W	
R2	1M	Metal film resistor, 1/4W	
R3	10k	Metal film resistor, 1/4W	
R4	10k	Metal film resistor, 1/4W	RC Booster and Bass RC use 22k.
R5	47k	Metal film resistor, 1/4W	Bass RC uses 22k.
R6	1k	Metal film resistor, 1/4W	RC Booster and Bass RC jumper this.
R7	4k7	Metal film resistor, 1/4W	
R8	4k7	Metal film resistor, 1/4W	
R9	33k	Metal film resistor, 1/4W	
R10	10k	Metal film resistor, 1/4W	
R11	470k	Metal film resistor, 1/4W	
R12	10k	Metal film resistor, 1/4W	
R13	470R	Metal film resistor, 1/4W	
R14	100k	Metal film resistor, 1/4W	
R15	15k	Metal film resistor, 1/4W	
R16	6k8	Metal film resistor, 1/4W	
R17	22k	Metal film resistor, 1/4W	
RPD	1M	Metal film resistor, 1/4W	Input pulldown resistor.
LEDR	4k7	Metal film resistor, 1/4W	LED current-limiting resistor. Adjust value to change LED brightness.
C1	22n	Film capacitor, 7.2 x 2.5mm	RC Booster uses 1uF. Bass RC Booster uses 100n.
C2	47n	Film capacitor, 7.2 x 2.5mm	RC Booster and Bass RC use 1uF.
C3	150pF	MLCC capacitor, NP0/COG	
C4	100n	Film capacitor, 7.2 x 2.5mm	RC Booster and Bass RC omit this.
C5	33n	Film capacitor, 7.2 x 2.5mm	
C6	33n	Film capacitor, 7.2 x 2.5mm	
C7	4n7	Film capacitor, 7.2 x 2.5mm	Bass RC uses 10n.
C8	4n7	Film capacitor, 7.2 x 2.5mm	Bass RC uses 10n.
C9	1uF	Film capacitor, 7.2 x 3.5mm	
C10	100n	Film capacitor, 7.2 x 2.5mm	
C11	10uF	Electrolytic capacitor, 5mm	

PARTS LIST, CONT.

PART	VALUE	TYPE	NOTES
C12	100uF	Electrolytic capacitor, 6.3mm	Power supply filter capacitor.
C13	47uF	Electrolytic capacitor, 5mm	Reference voltage filter capacitor.
C14	100n	MLCC capacitor, X7R	Power supply filter capacitor.
D1	1N5817	Schottky diode, DO-41	
D2	1N914	Fast-switching diode, DO-35	Bass RC omits this diode.
D3	1N914	Fast-switching diode, DO-35	Bass RC omits this diode.
D4	(jumper)		RC Booster uses 1N914 instead of jumper. Bass RC omits this diode.
D5	1N914	Fast-switching diode, DO-35	RC Booster and Bass RC omit this diode.
D6	1N914	Fast-switching diode, DO-35	Bass RC omits this diode.
D7	1N914	Fast-switching diode, DO-35	RC Booster uses 1N914 instead of jumper. Bass RC omits this diode.
D8	(jumper)		RC Booster uses 1N914 instead of jumper. Bass RC omits this diode.
Q1	2N5088	BJT transistor, NPN, TO-92	Substitute. Original uses 2SC1815.
Q2	2N5088	BJT transistor, NPN, TO-92	Substitute. Original uses 2SC1815.
IC1	JRC4558D	Operational amplifier, DIP8	Substitute. Original likely uses JRC4557 (out of production & almost impossible to find).
IC1-S	DIP-8 socket	IC socket, DIP-8	
GAIN	1MB	16mm right-angle PCB mount pot	RC Booster uses 250kB.
BASS	50kB	16mm right-angle PCB mount pot	
TREBLE	50kB	16mm right-angle PCB mount pot	
LEVEL	100kB	16mm right-angle PCB mount pot	
LED	5mm	LED, 5mm, red diffused	
IN	1/4" stereo	1/4" phone jack, closed frame	Switchcraft 112BX or equivalent.
OUT	1/4" mono	1/4" phone jack, closed frame	Switchcraft 111X or equivalent.
DC	2.1mm	DC jack, 2.1mm panel mount	Mouser 163-4302-E or equivalent.
BATT	Battery snap	9V battery snap	Optional. Use the soft plastic type—the hard-shell type will not fit.
FSW	3PDT	Stomp switch, 3PDT	
ENC	125B	Enclosure, die-cast aluminum	Can also use a Hammond 1590N1.

BUILD NOTES

Building the RC Booster

The schematic and parts list are given for the AC Booster, but only a handful of parts substitutions are needed for the RC Booster.

- **C1:** 22n → 1uF (non-polar film)
- **C2:** 100n → 1uF (non-polar film)
- **C4:** omit (leave empty)
- **R4:** 10k → 22k
- **R6:** jumper
- **D4:** 1N914
- **D5:** omit (leave empty)
- **D8:** 1N914
- **Drive:** 1MB → 250kB

If you're interested in experimenting, you could socket the parts to see the exact changes, and perhaps you'll end up with your own hybrid that's more to your preference.

Building the Bass RC Booster

Starting with the RC Booster changes above, make the following substitutes:

- **C1:** 1uF → 100n
- **C7:** 4n7 → 10n
- **C8:** 4n7 → 10n
- **R5:** 47k → 22k
- **D2-8:** omit (leave empty)

SCHEMATIC

Shown with AC Booster values.

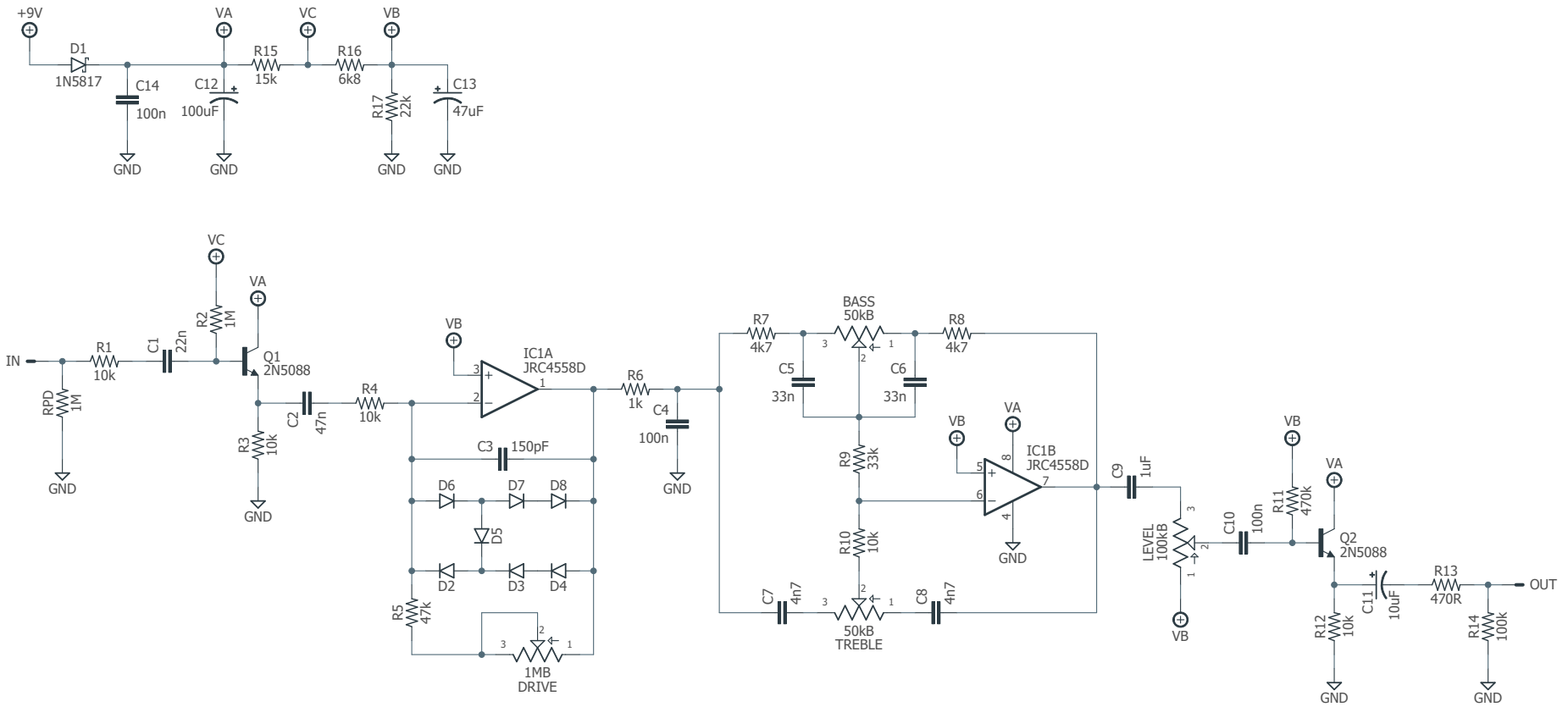

DRILL TEMPLATE

Cut out this drill template, fold the edges and tape it to the enclosure. Before drilling, it's recommended to first use a center punch for each of the holes to help guide the drill bit.

Ensure that this template is printed at 100% or "Actual Size". You can double-check this by measuring the scale on the printed page.

Top jack layout assumes the use of closed-frame jacks like the [Switchcraft 111X](#). If you'd rather use open-frame jacks, please refer to the Open-Frame Jack Drill Template for the top side.

LED hole drill size assumes the use of a [5mm LED bezel](#), available from several parts suppliers. Adjust size accordingly if using something different, such as a 3mm bezel, a plastic bezel, or just a plain LED.

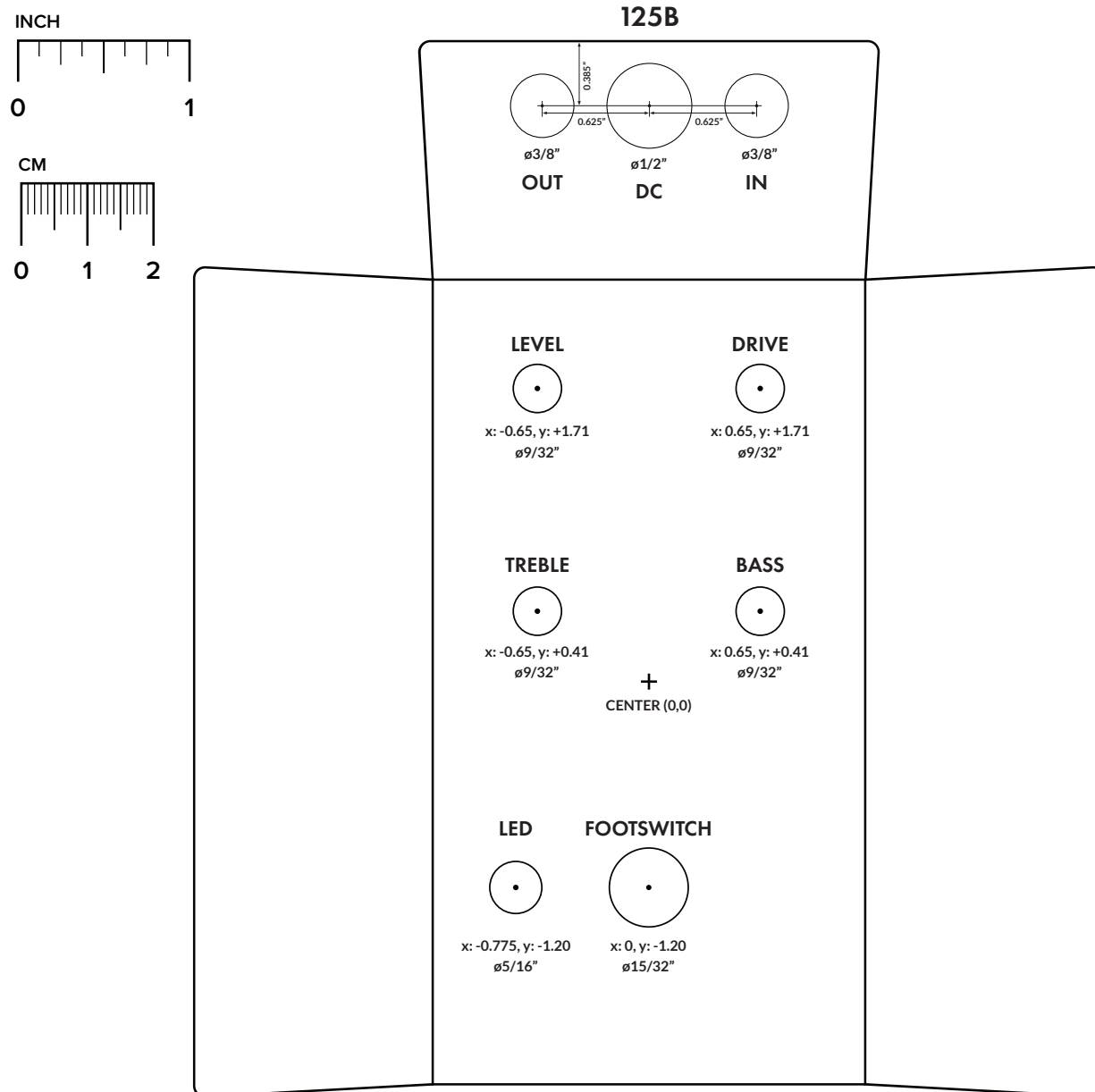

ENCLOSURE LAYOUT

Enclosure is shown without jacks. See next page for jack layout and wiring.

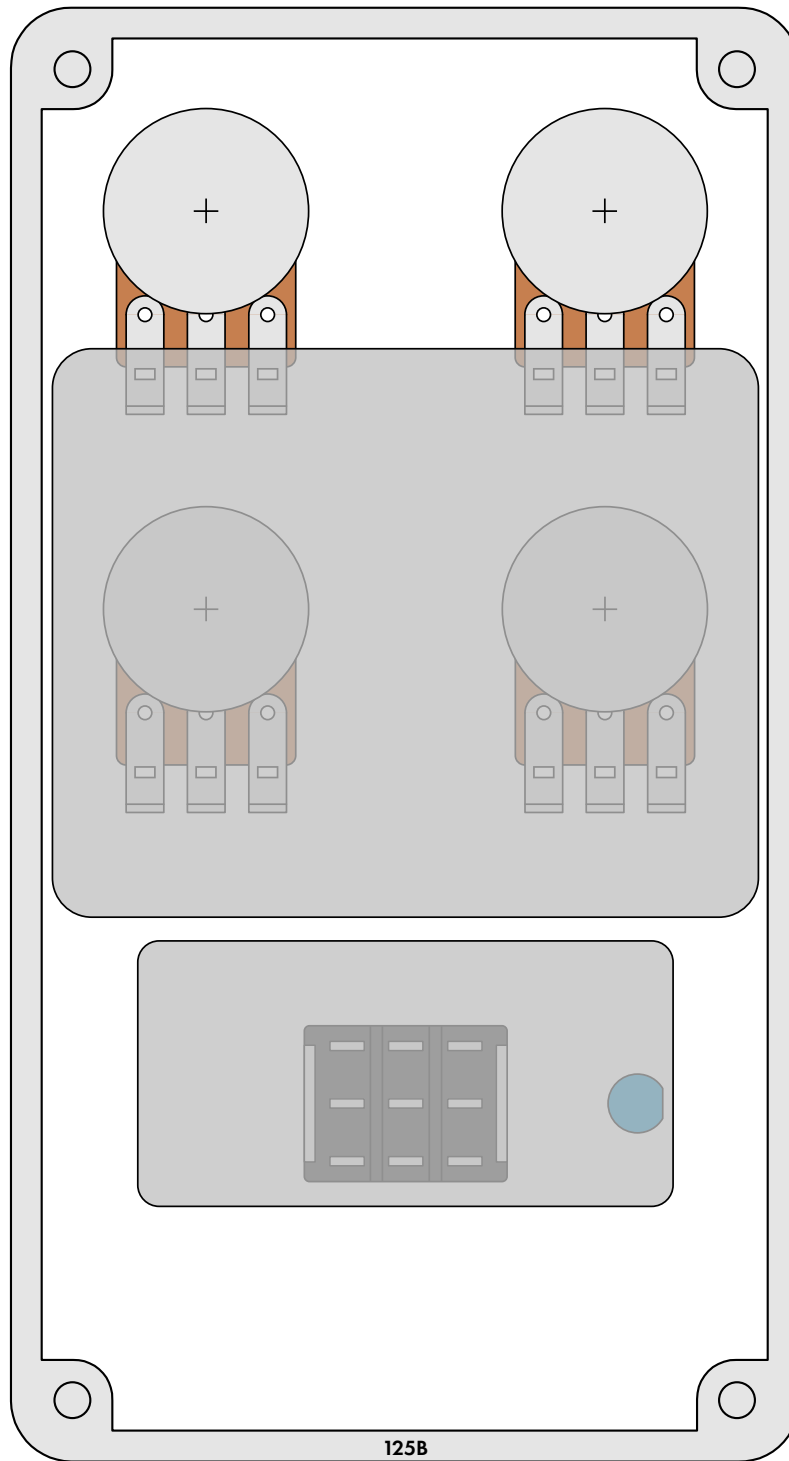

WIRING DIAGRAM

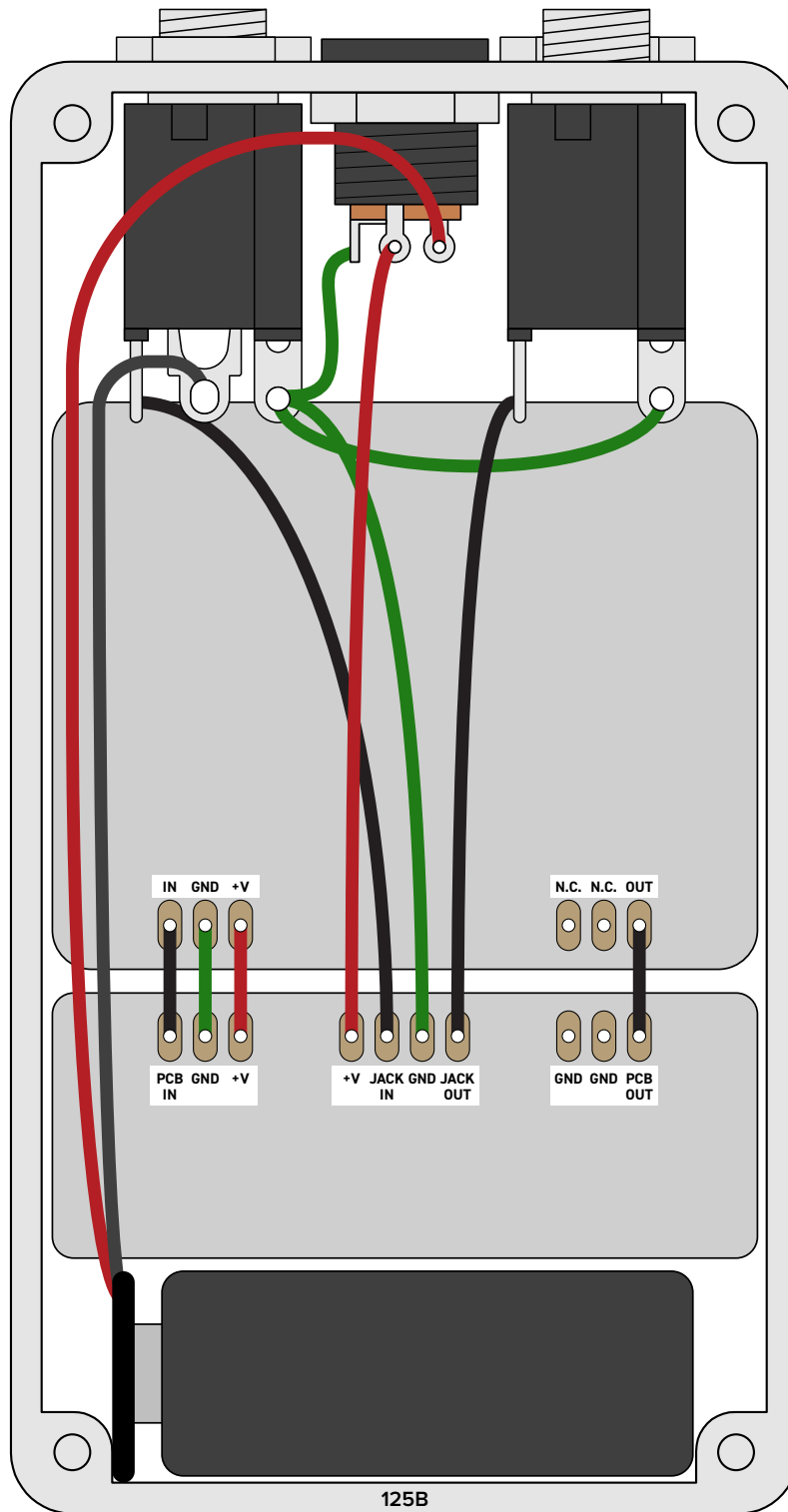

*Shown with optional 9V battery. If battery is omitted, both jacks can be mono rather than one being stereo.
Leave the far-right lug of the DC jack unconnected.*

LICENSE & USAGE

No direct support is offered for these projects beyond the provided documentation. It's assumed that you have at least some experience building pedals before starting one of these. Replacements and refunds cannot be offered unless it can be shown that the circuit or documentation are in error.

All of these circuits have been tested in good faith in their base configurations. However, not all the modifications or variations have necessarily been tested. These are offered only as suggestions based on the experience and opinions of others.

Projects may be used for commercial endeavors in any quantity unless specifically noted. No attribution is necessary, though a link back is always greatly appreciated. The only usage restrictions are that **(1) you cannot resell the PCB as part of a kit without prior arrangement, and (2) you cannot “goop” the circuit, scratch off the screenprint, or otherwise obfuscate the circuit to disguise its source.** (In other words: you don't have to go out of your way to advertise the fact that you use these PCBs, but please don't go out of your way to hide it. The guitar effects industry needs more transparency, not less!)

DOCUMENT REVISIONS

2.0.0 (2020-06-26)

Updated PCB layout based on direct traces of different variants of the AC and RC Booster pedals.

1.0.0 (2018-09-22)

Initial release.