

PROJECT NAME

# LUMITRON



BASED ON  
Mu-tron® III

BUILD DIFFICULTY  
■■■■□ Intermediate

EFFECT TYPE  
Envelope filter / auto-wah

DOCUMENT VERSION  
1.1.0 (2024-11-29)

## PROJECT SUMMARY

The very first commercial envelope filter effect, first released in 1972. Famously used by Bootsy Collins, Jerry Garcia and Stevie Wonder among many others.

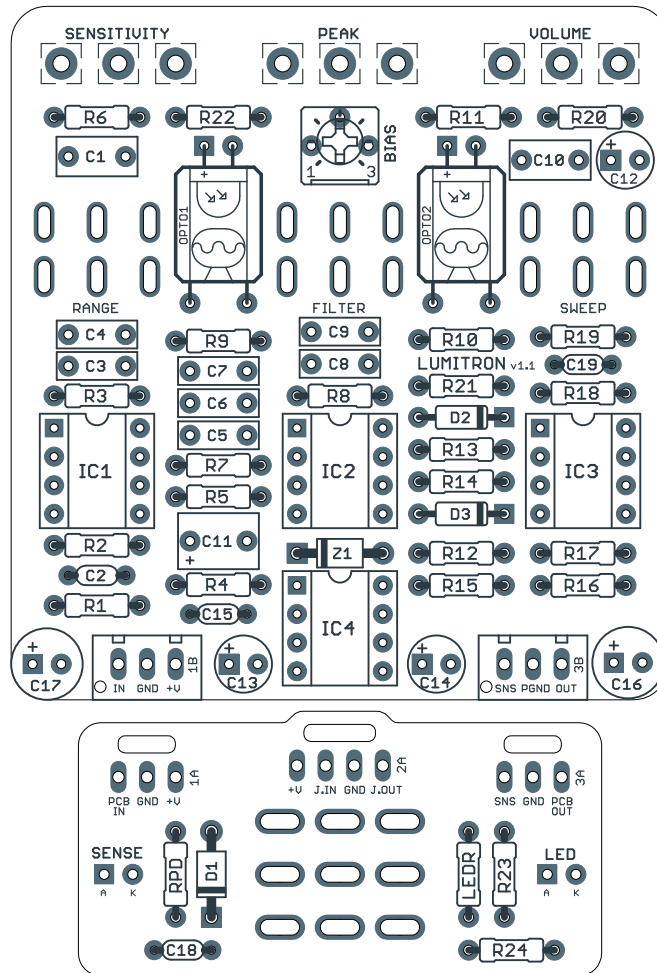

Actual size is 2.3" x 2.42" (main board) and 1.78" x 0.86" (bypass board).

# TABLE OF CONTENTS

---

1	Project Overview	9	Drill Template
2	Introduction & Usage	10	Enclosure Layout
3-5	Parts List	11	Wiring Diagram
6-7	Build Notes	12	Licensing
8	Schematic	12	Document Revisions

## INTRODUCTION

---

The Lumitron Resonant Filter is an adaptation of the Musitronics Mu-tron III, designed by Mike Biegel and originally released in 1972.

The Mu-tron III was the very first commercial envelope filter pedal, also called an autowah, using optocouplers to dynamically control a series of frequency filters based on the level of the input signal. The vocal-like effect was quickly embraced by musicians and soon became a characteristic effect of entire genres, particularly funk. Notable Mu-tron III users include Bootsy Collins on bass, Jerry Garcia on guitar, and even Stevie Wonder, who used it on a Clavinet.

Musitronics was sold to ARP in 1979, who produced the pedals until 1980. Mike Biegel later contracted with Electro-Harmonix to release an updated version of the circuit in 1995, called the Q-Tron, as well as the Bi-Filter rack unit with expanded features. The original Q-Tron was later adapted as the Mini Q-Tron, Micro Q-Tron, and Q-Tron+, the latter two of which are still in production.

In 2019, the Mu-tron brand was resurrected with Mike Biegel once again designing new effects. The Micro-Tron IV is an updated version of the Mu-tron III, with modernized circuitry, CV input and output, and swappable optical modules for different reaction times and filter characteristics.

The Lovetone Meatball (available as our [Spectron](#) project) was based on the Mu-tron III with a greatly expanded feature set. If you wish the Lumitron had a lot more knobs and switches, it's well worth a look.

## USAGE

---

The Lumitron has three knobs and three switches:

- **Sensitivity** boosts the signal level at the input, which drives the envelope detector as well as the main audio signal path.
- **Peak** is a feedback control that sets the sharpness or intensity of the filter.
- **Volume** is the output volume of the effect, which compensates for high input gain levels.
- **Filter** (toggle switch) selects the filter type. LP (lowpass) accentuates lows. BP (bandpass) cuts lows and highs while accentuating the peak frequency. HP (highpass) accentuates highs.
- **Sweep** (toggle switch) selects the direction of the sweep. "Up" starts with a hi-cut and adds highs with the intensity of the signal. "Down" starts with a low-cut and adds lows with the intensity.
- **Range** (toggle switch) sets the input frequency of the envelope detector. "Lo" is more sensitive to bass signals while "Hi" is more sensitive to treble signals.

## PARTS LIST

This parts list is also available in a spreadsheet format which can be imported directly into Mouser for easy parts ordering. Mouser doesn't carry all the parts—notably potentiometers—so the second tab lists all the non-Mouser parts as well as sources for each.

[View parts list spreadsheet](#) →

PART	VALUE	TYPE	NOTES
R1	3k3	Metal film resistor, 1/4W	
R2	120k	Metal film resistor, 1/4W	
R3	120k	Metal film resistor, 1/4W	
R4	4k7	Metal film resistor, 1/4W	
R5	12k	Metal film resistor, 1/4W	
R6	390k	Metal film resistor, 1/4W	
R7	22k	Metal film resistor, 1/4W	
R8	22k	Metal film resistor, 1/4W	
R9	220k	Metal film resistor, 1/4W	
R10	220k	Metal film resistor, 1/4W	
R11	560R	Metal film resistor, 1/4W	
R12	22k	Metal film resistor, 1/4W	
R13	12k	Metal film resistor, 1/4W	
R14	1M	Metal film resistor, 1/4W	
R15	1M	Metal film resistor, 1/4W	
R16	330R	Metal film resistor, 1/4W	
R17	47k	Metal film resistor, 1/4W	
R18	120k	Metal film resistor, 1/4W	
R19	180k	Metal film resistor, 1/4W	
R20	120k	Metal film resistor, 1/4W	
R21	120k	Metal film resistor, 1/4W	
R22	680R	Metal film resistor, 1/4W	
R23	1k	Metal film resistor, 1/4W	Used for envelope indicator LED.
R24	1k	Metal film resistor, 1/4W	Used for envelope indicator LED.
RPD	2M2	Metal film resistor, 1/4W	Input pull-down resistor. Can be as low as 1M.
LEDR	10k	Metal film resistor, 1/4W	LED current-limiting resistor. Adjust value to change LED brightness.
C1	1uF	Film capacitor, 7.2 x 3.5mm	
C2	10pF	MLCC capacitor, NP0/C0G	
C3	100n	Film capacitor, 7.2 x 2.5mm	
C4	2n2	Film capacitor, 7.2 x 2.5mm	
C5	1n	Film capacitor, 7.2 x 2.5mm	
C6	1n8	Film capacitor, 7.2 x 2.5mm	

## PARTS LIST, CONT.

PART	VALUE	TYPE	NOTES
C7	2n2	Film capacitor, 7.2 x 2.5mm	
C8	1n	Film capacitor, 7.2 x 2.5mm	
C9	1n8	Film capacitor, 7.2 x 2.5mm	
C10	1uF	Film capacitor, 7.2 x 3.5mm	
C11	2.2uF	Film capacitor, 7.2 x 5mm	
C12	4.7uF	Electrolytic capacitor, 4mm	
C13	10uF	Electrolytic capacitor, 5mm	
C14	10uF	Electrolytic capacitor, 5mm	Power supply filter capacitor.
C15	470n	MLCC capacitor, X7R	Power supply filter capacitor.
C16	100uF	Electrolytic capacitor, 6.3mm	Power supply filter capacitor.
C17	100uF	Electrolytic capacitor, 6.3mm	Power supply filter capacitor.
C18	100n	MLCC capacitor, X7R	Power supply filter capacitor.
C19	100pF	MLCC capacitor, NPO/COG	Added in v1.1. See build notes.
Z1	1N4742A	Zener diode, 12V, DO-41	
D1	1N5817	Schottky diode, DO-41	
D2	1N914	Fast-switching diode, DO-35	
D3	1N914	Fast-switching diode, DO-35	
IC1	RC4558P	Operational amplifier, dual, DIP8	
IC1-S	DIP-8 socket	IC socket, DIP-8	
IC2	RC4558P	Operational amplifier, dual, DIP8	
IC2-S	DIP-8 socket	IC socket, DIP-8	
IC3	RC4558P	Operational amplifier, dual, DIP8	
IC3-S	DIP-8 socket	IC socket, DIP-8	
IC4	LT1054CP	Charge pump, DIP8	Can also use TC1044SCPA.
IC4-S	DIP-8 socket	IC socket, DIP-8	
BIAS	5k trimmer	Trimmer, 10%, 1/4"	Bourns 3362P
OPTO1	VTL5C3	Vactrol, fast on/fast off	Available from <a href="#">Aion FX</a> . See build notes.
OPTO2	VTL5C3	Vactrol, fast on/fast off	Available from <a href="#">Aion FX</a> . See build notes.
SENSITIVITY	1MC	16mm right-angle PCB mount pot	
PEAK	250kA	16mm right-angle PCB mount pot	
VOLUME	100kA	16mm right-angle PCB mount pot	
SWEEP	DPDT on-on	Toggle switch, DPDT on-on	
FILTER	DPDT on-on-on	Toggle switch, DPDT on-on-on	
RANGE	DPDT on-off-on	Toggle switch, DPDT center off	

## PARTS LIST, CONT.

PART	VALUE	TYPE	NOTES
LED	5mm	LED, 5mm, red diffused	
SENSE	5mm	LED, 5mm, red diffused	Can also use a different color to differentiate from bypass LED.
IN	1/4" mono	1/4" phone jack, closed frame	Switchcraft 111X or equivalent.
OUT	1/4" mono	1/4" phone jack, closed frame	Switchcraft 111X or equivalent.
DC	2.1mm	DC jack, 2.1mm panel mount	Mouser 163-4302-E or equivalent.
FSW	3PDT	Stomp switch, 3PDT	
ENC	125B	Enclosure, die-cast aluminum	Can also use a Hammond 1590N1.

## BUILD NOTES

---

### Setting the bias trimmer

The original units did not have a trimmer for the bias control. They used a fixed resistor in this position whose value depended on the specs of the optocoupler. Mu-tron's process for selecting this resistor value is not known.

In the Lumitron, as with many other DIY clones, we've made this a trimmer so that the resistance value can be adjusted to preference. Start with the trimmer in the middle and turn it to the left and right to see how it changes the sound, then leave it where it sounds best.

Some Mu-tron clones make this an external control, and you're welcome to wire it offboard if you like, but there is generally a sweet spot and on-the-fly adjustment isn't nearly as useful once it's been set.

### Vactrol selection

The original Mu-tron III used a dual-element optocoupler from Hamamatsu, marked with the part number 805A, which had a single LED and two fully independent LDRs in one package.

There is no record of the 805A part number in Hamamatsu's catalogs or datasheets. However, the Mu-tron III service manual from after the ARP acquisition (1979) lists it as the P873-13, which is a standard Hamamatsu part with the same dual-LDR configuration and the same physical appearance.

It's not known whether the 805A is just an internal part number or if Hamamatsu may have produced it specially for Mu-tron, either a custom specification or selected for certain characteristics. It's known that they had Hamamatsu manufacture custom optocouplers for the Phasor II, so they did have a direct relationship with the company that went beyond just ordering from a catalog.

Regardless, there is nothing particularly notable about the specifications of the P873-13 other than the dual LDR. Most Mu-tron III clones just use two fully separate optocouplers with the LEDs in series or parallel, which makes no difference to the operation.

It's recommended to use the [VTL5C3](#) here, as it's been used successfully for years in DIY adaptations. This is also the type used in the EHX Q-Tron, a variant of the Mu-tron III that was designed by Mike Biegel for EHX in the 1990s. Other types such as the NSL-32 can be made to work, but you may have to modify some of the surrounding circuitry since the "on" resistance is much lower.

### Series vs. parallel LEDs

In the original Lumitron, the LEDs were in parallel, following Madbean's various Mu-tron implementations such as the Nautilus and NaughtyFish. In version 1.1, we changed this to series, following R.G. Keen's [Neutron](#). There is no difference when using the VTL5C3 since the LEDs are very consistent between parts, but it should work better in situations where the LEDs are not as well matched, which can happen when using discrete LED-LDR pairs.

### C19 capacitor

Version 1.1 adds C19, a 100pF capacitor in the feedback loop of the envelope detector op-amp. This solves a rare issue where the op-amp will oscillate and kill the gain or cause a crackling or distorted noise. It's recommended to include in all builds since there are no changes to the sound.

## BUILD NOTES, CONT.

---

### Peak potentiometer value

In the original units, the Peak control was a 150kA (log/audio taper) potentiometer. This value is very difficult to find today, so it's recommended to use 250kA with a 390k resistor in parallel (R6), which approximates a 150kA pot. If you do manage to find a 150kA potentiometer, you can omit R6 entirely.

### Envelope indicator LED

The footswitch PCB includes a second LED that shows the envelope. This correlates closely to the optocoupler LEDs that drive the filter, so it's a good way of seeing the action directly. Note that if the "Drive" switch is set to DOWN (in other words, it starts high and sweeps low with the envelope), the LED will be on by default and will turn off when the envelope detector engages.

If you want to omit this LED, you can just leave the LED unpopulated along with R23 and R24 on the footswitch board. No jumpers are necessary. Just make sure to only drill the left-side LED hole on the drill template.

### DPDT switches

The Lumitron uses three DPDT switches and each of them is a different type. Be very careful that you have the correct switch in the correct position before soldering.

The Sweep switch is a DPDT **on-on**, selecting between two positions, "Up" and "Down".

The Range switch is a DPDT **on-off-on** with three positions. This is a modification to the original Mu-tron III circuit, adding an in-between "Medium" mode in addition to "Low" and "High".

The Filter switch is a DPDT **on-on-on**, selecting between lowpass, bandpass and highpass. (In the original unit, this was a 3-position rotary switch.) For this type of on-on-on switch, there are two different configurations for the center position depending on the manufacturer, which are as follows:

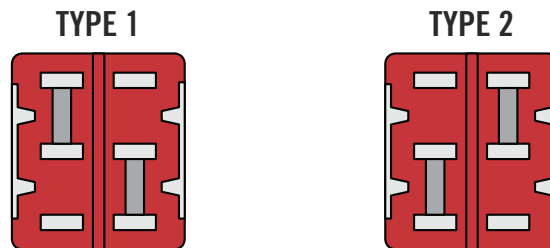

The Lumitron requires the **Type 2** configuration, which is used by most major manufacturers such as Taiway. If you're considering a different brand, make sure you know the configuration of the center position. Many of the off-brand on-on-on switches such as the ones sold by Tayda Electronics are Type 1 and will not work in this circuit.

# SCHEMATIC

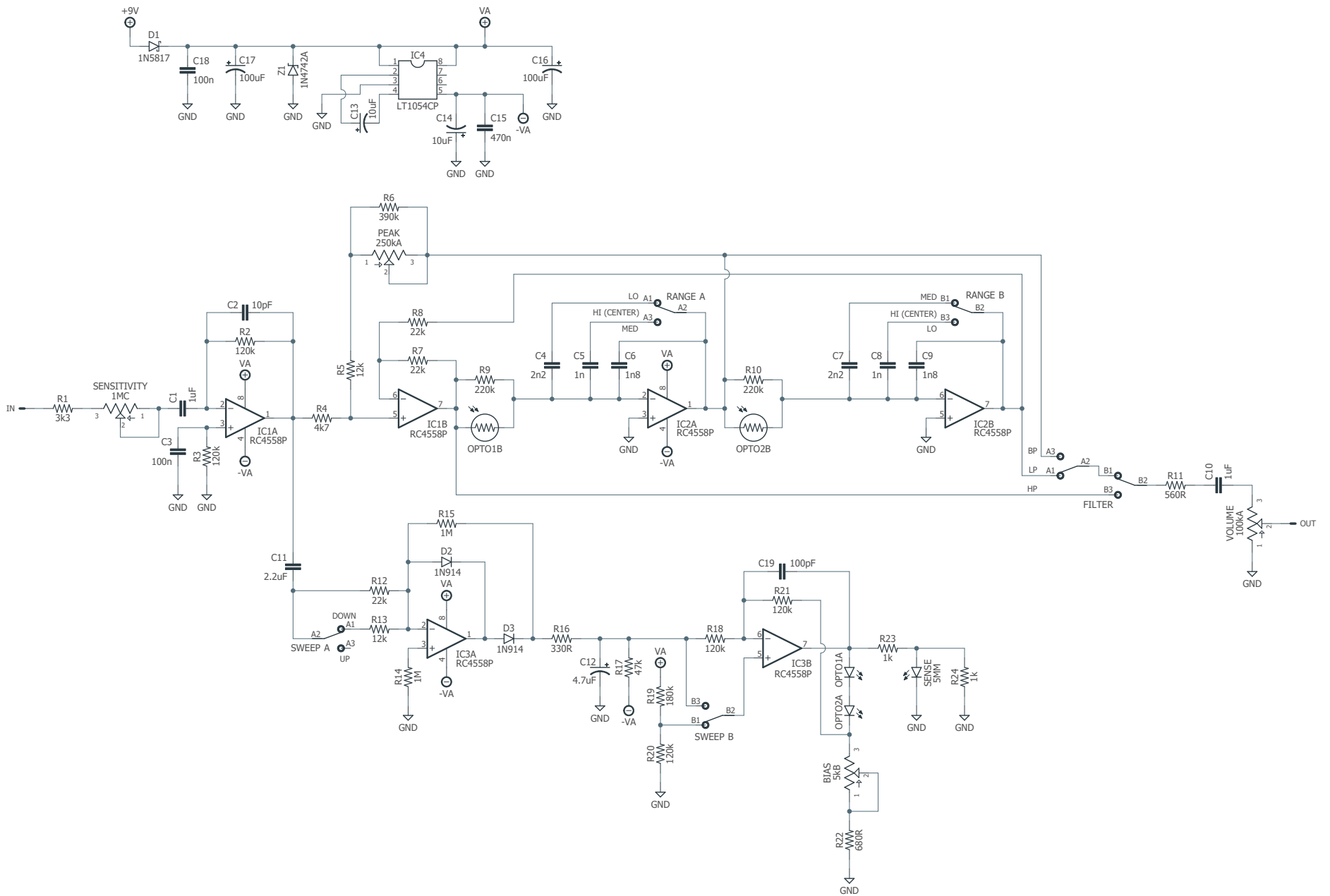



# DRILL TEMPLATE

Cut out this drill template, fold the edges and tape it to the enclosure. Before drilling, it's recommended to first use a center punch for each of the holes to help guide the drill bit.

Ensure that this template is printed at 100% or "Actual Size". You can double-check this by measuring the scale on the printed page.

**Top jack layout** assumes the use of closed-frame jacks like the [Switchcraft 111X](#). Open-frame jacks will not fit in layouts with 3 knobs along the top due to the placement of the DC jack.

**LED hole drill size** assumes the use of a [5mm LED bezel](#), available from several parts suppliers. Adjust size accordingly if using something different, such as a 3mm bezel, a plastic bezel, or just a plain LED.

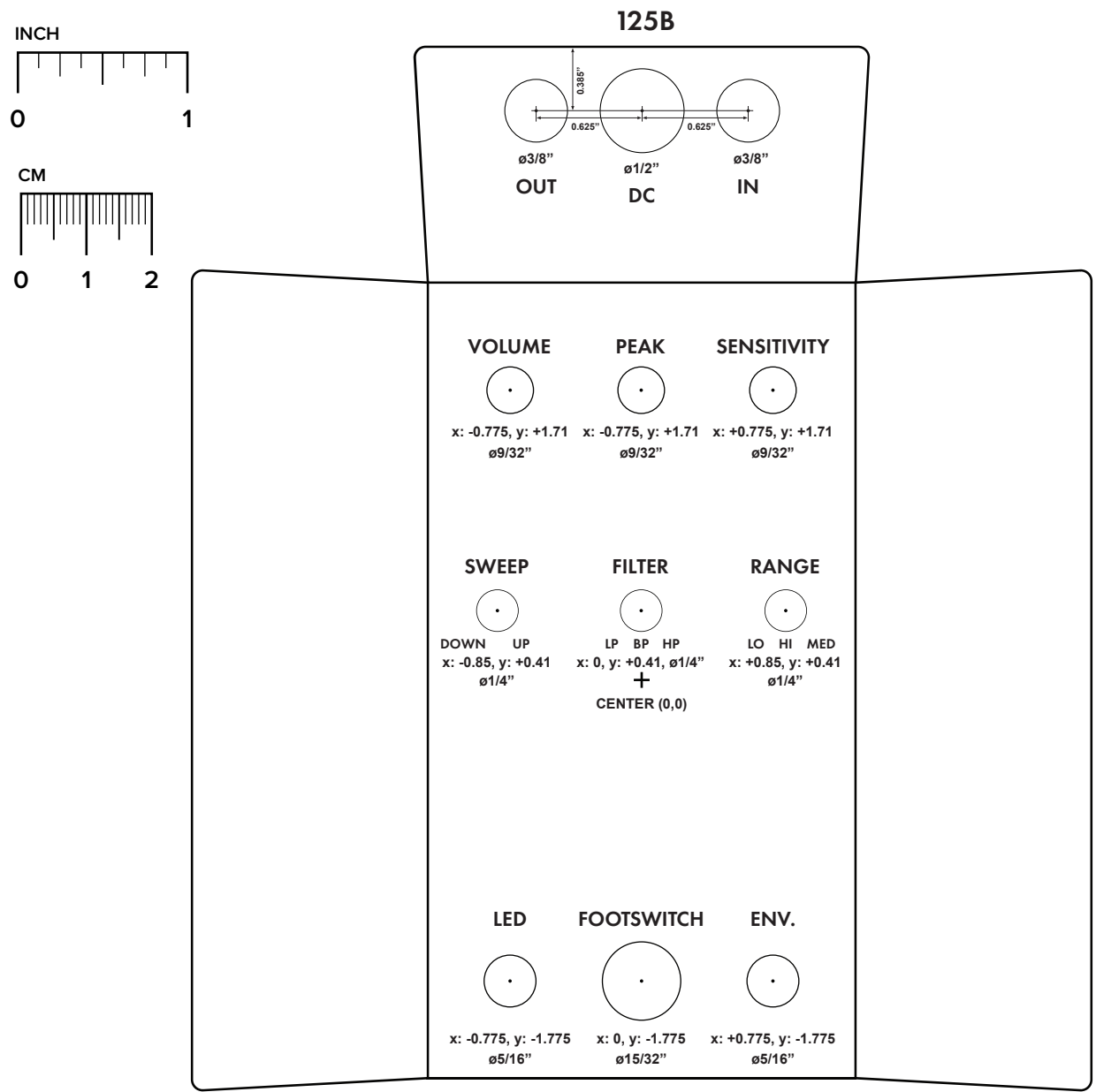

# ENCLOSURE LAYOUT

---

Enclosure is shown without jacks. See next page for jack layout and wiring.

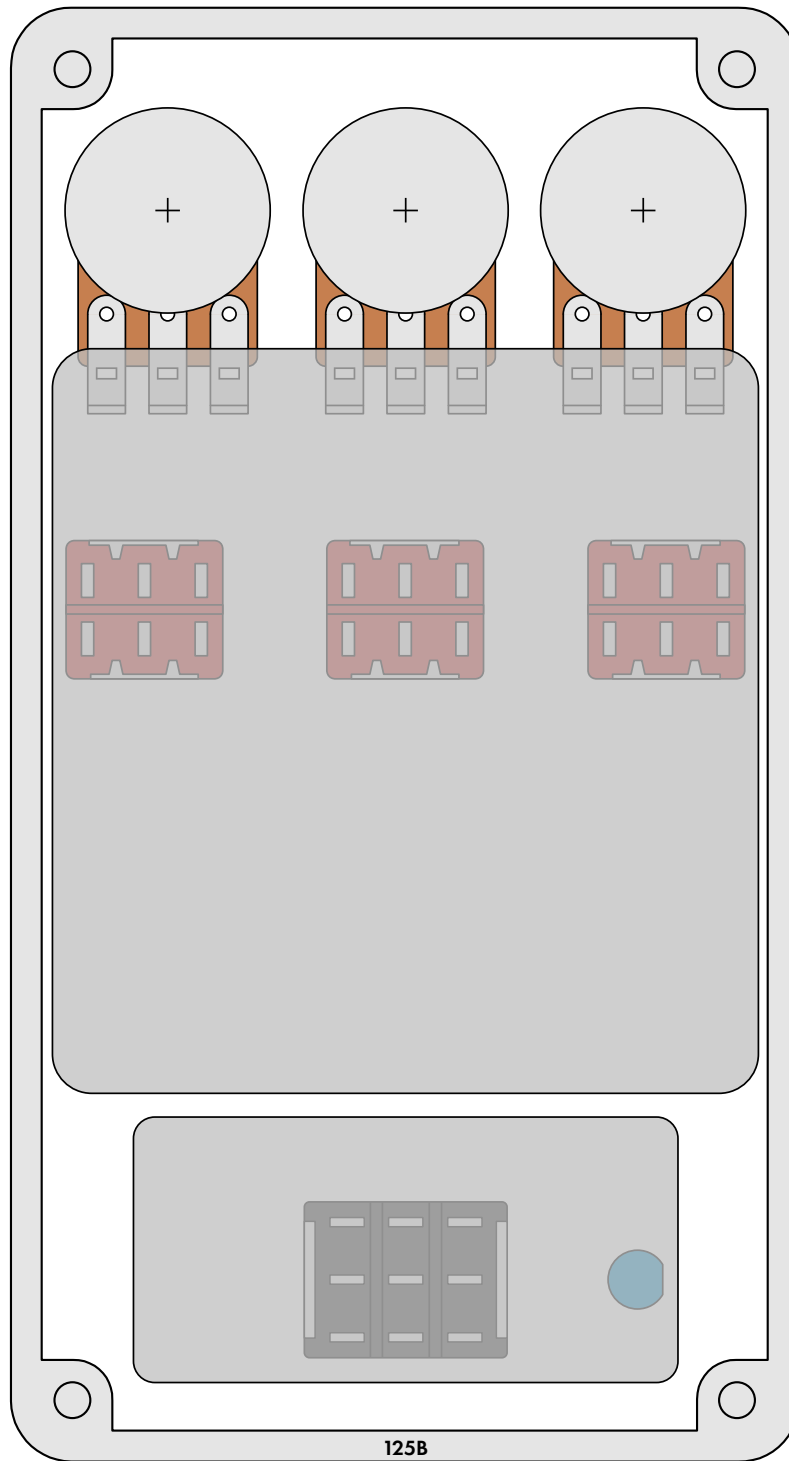

# WIRING DIAGRAM

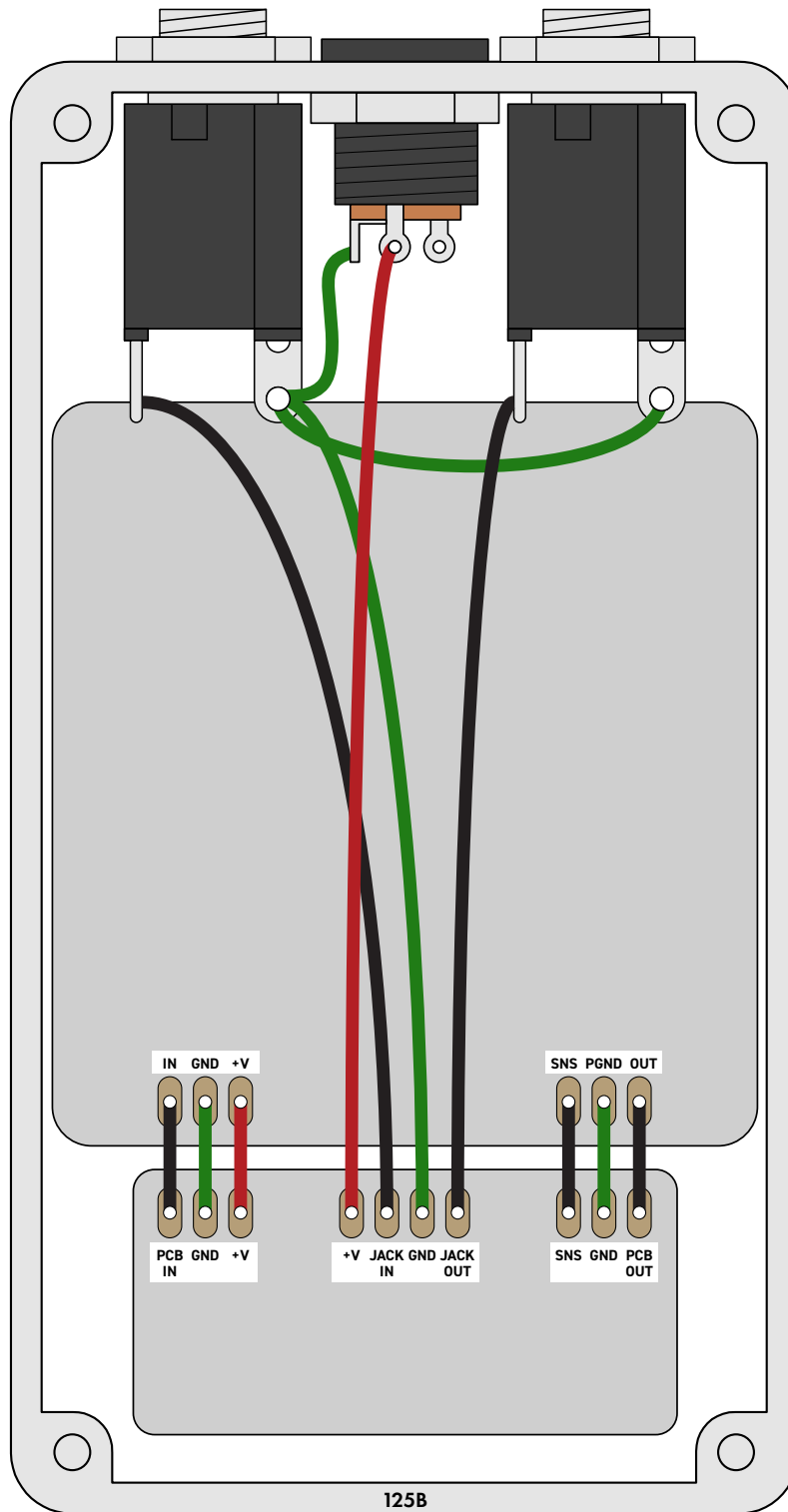

## LICENSE & USAGE

---

**No direct support is offered for these projects beyond the provided documentation.** It's assumed that you have at least some experience building pedals before starting one of these. Replacements and refunds cannot be offered unless it can be shown that the circuit or documentation are in error.

**All of these circuits have been tested in good faith in their base configurations.** However, not all the modifications or variations have necessarily been tested. These are offered only as suggestions based on the experience and opinions of others.

**Projects may be used for commercial endeavors in any quantity** unless specifically noted. No attribution is necessary, though a link back is always greatly appreciated. The only usage restrictions are that **(1) you cannot resell the PCB as part of a kit without prior arrangement, and (2) you cannot “goop” the circuit, scratch off the screenprint, or otherwise obfuscate the circuit to disguise its source.** (In other words: you don't have to go out of your way to advertise the fact that you use these PCBs, but please don't go out of your way to hide it. The guitar effects industry needs more transparency, not less!)

## DOCUMENT REVISIONS

---

### 1.1.0 (2024-11-29)

- Changed optocoupler LEDs from parallel to series so it works better with a wider variety of LEDs and LEDRs. See build notes for more details.
- Changed R22 (minimum bias resistor for optocoupler LEDs) from 330R to 680R.
- Added C19, a 100pF capacitor in the feedback loop of IC3B, which can help prevent oscillation or distortion in the envelope detector.
- Renamed controls: (PCB label only, no circuit changes)
  - “Gain” changed to “Sensitivity”
  - “Drive” changed to “Sweep”
  - “Sweep” (trimmer) changed to “Bias”

### 1.0.2 (2023-12-15)

Added switch position labels to the drill template.

### 1.0.1 (2023-09-11)

Added more info about the DPDT switches.

### 1.0.0 (2023-09-08)

Initial release.