

PROJECT NAME

# HELIODOR

BASED ON

BOSS® OD-3 Overdrive

EFFECT TYPE

Overdrive

BUILD DIFFICULTY

■■■■□ Intermediate

DOCUMENT VERSION

1.0.0 (2024-06-01)

**QION**  
DIY GUITAR EFFECTS

## PROJECT SUMMARY

The final entry in a series of legendary pedals using BOSS's "discrete op-amp" topology that overdrives more like an amplifier than traditional drive circuits.



### IMPORTANT NOTE

This documentation is for the **kit** version of the project. If you purchased the PCB by itself, please use the [PCB-only version](#) of the documentation instead. The circuit is the same, but the instructions are completely different due to the specialized parts and assembly methods used in the kit.

# TABLE OF CONTENTS

---

- 1 Project Overview
- 2 Table of Contents
- 3 Introduction
- 4 Packing List
- 5 Packing List (Cont.)
- 6 Tools Needed
- 7 Component Identification
- 8 Hardware Identification
- 9 Overview
- 10 Resistors
- 11 Diodes
- 12 Sockets & ICs
- 13 Transistors
- 14 JFETs
- 15 Capacitors (Non-Polarized)
- 16 Wire Headers
- 17 Capacitors (Polarized)
- 18 Footswitch PCB
- 19 Input/Output PCB
- 20 Enclosure Layout: Panel Mounts
- 21 Enclosure Layout: Main & Footswitch PCBs
- 22 Enclosure Layout: Input/Output PCB
- 23 Final Testing & Assembly
- 24 Schematic
- 25 Full Parts List
- 26 Troubleshooting Information
- 27 Support & Resale Terms
- 28 Legal Information & Document Revisions

# INTRODUCTION

---

If this is your first pedal, welcome to the hobby and thank you for choosing Aion FX. You've just joined a community of over 40,000 people around the world with a passion for building homemade noise machines using obsolete electronics technologies, and we're glad to have you!

If you've done this before, it's great to see you again and we're confident you'll find this build experience an enjoyable one.

Aion FX kits are designed to empower anyone to build a high-quality pedal, no matter the skill level. The pedalbuilding hobby has traditionally had a steep learning curve, but don't be overwhelmed—we've done all the hard work for you. All you need to do is follow these instructions and you'll be on your way to transforming your tone.

There are a few things to go over before you get started.

- **You're going to have to get your hands dirty**—there's no way around it. Nothing here comes preassembled, and you'll have to learn the skills to put it all together. This document will walk you through everything you need, but be prepared to learn a few things along the way.
- **This will take time.** Plan on about two hours start to finish. It may take even longer if it's your first time building. Don't rush it. If you find yourself getting frustrated or overwhelmed, take a break and come back in a couple of hours or the next day.
- **No direct technical support is offered.** There are several DIY forums and Facebook groups with thousands of members who enjoy troubleshooting and teaching. But please be sensitive to the fact that the staff at Aion FX is minimal, and every minute spent helping individuals in private is time that can't be spent on new project development.
- **There is no implied guarantee of a final product.** Aion FX provides the ingredients and the recipe, but you are responsible for putting everything together to make it work. We've tried to make the process as clear and accessible as possible, but it must be expressly stated that purchasing the kit is not a guarantee that you will end up with a working pedal.

It's recommended to read through all of the instructions before you start, particularly if you've never built a pedal before. If you familiarize yourself with the entire process ahead of time and you know what the goal looks like, each step will make more sense.

Now, on to the fun stuff!

# PACKING LIST

---

This is a list of all the parts that are included with the kit, grouped by value. For a list of all the parts based on their PCB part numbers, please see page 25.

If you find that any parts are missing or damaged, please fill out the [Missing Parts](#) form.

## Film Capacitors

| NAME        | QTY |
|-------------|-----|
| 1n2         | 1   |
| 6n8         | 1   |
| 10n (0.01)  | 1   |
| 12n (0.012) | 1   |
| 18n (0.018) | 2   |
| 22n (0.022) | 1   |
| 33n (0.033) | 1   |
| 47n (0.047) | 1   |
| 56n (0.056) | 2   |
| 470n (0.47) | 2   |
| 1uF         | 5   |

## Electrolytic Capacitors

| NAME  | QTY |
|-------|-----|
| 10uF  | 2   |
| 47uF  | 1   |
| 100uF | 1   |

## MLCC Capacitors

| NAME                | QTY |
|---------------------|-----|
| 47pF (marked "470") | 1   |
| 100n (marked "104") | 1   |

## Transistors

| NAME                       | QTY |
|----------------------------|-----|
| 2N3906                     | 1   |
| 2N5088                     | 1   |
| 2SK209-GR with PCB adapter | 5   |

## Resistors

| NAME | QTY |
|------|-----|
| 470R | 1   |
| 1k   | 3   |
| 2k2  | 1   |
| 2k7  | 2   |
| 3k3  | 2   |
| 4k7  | 3   |
| 6k8  | 2   |
| 10k  | 9   |
| 12k  | 2   |
| 22k  | 1   |
| 33k  | 1   |
| 47k  | 1   |
| 100k | 4   |
| 150k | 1   |
| 220k | 2   |
| 1M   | 1   |
| 2M2  | 1   |

## Diodes

| NAME   | QTY |
|--------|-----|
| 1N5817 | 1   |
| 1N914  | 6   |

## ICs

| NAME         | QTY |
|--------------|-----|
| JRC4558D     | 1   |
| 8-pin socket | 1   |

## PACKING LIST (CONT.)

---

### Potentiometers

| NAME                                | QTY |
|-------------------------------------|-----|
| 10kB                                | 1   |
| 100kA                               | 1   |
| 100kB                               | 1   |
| Dust cover                          | 3   |
| Knob                                | 3   |
| Mounting nut, potentiometer, 0.44"  | 3   |
| Lock washer, potentiometer, 0.5"    | 3   |
| Outer washer, potentiometer, 0.475" | 3   |

### Other

| NAME                           | QTY |
|--------------------------------|-----|
| LED bezel                      | 1   |
| LED, white                     | 1   |
| DC jack                        | 1   |
| Input/output jack              | 2   |
| Mounting nut, jack, 0.54"      | 4   |
| Outer washer, jack, 0.6"       | 2   |
| Lock washer, jack, 0.5" (thin) | 2   |
| Enclosure                      | 1   |
| Enclosure screws               | 4   |
| PCB, main circuit              | 1   |
| PCB, footswitch                | 1   |
| PCB, input/output/DC           | 1   |

### Switches

| NAME                             | QTY |
|----------------------------------|-----|
| Stomp switch, 3PDT               | 1   |
| Mounting nut, stomp switch, 0.6" | 2   |
| Lock washer, stomp switch, 0.6"  | 1   |
| Dress nut, stomp switch, 0.77"   | 1   |

### Wiring

| NAME                          | QTY |
|-------------------------------|-----|
| 3-strand wire assembly, 70mm  | 2   |
| 4-strand wire assembly, 122mm | 1   |
| 3-pin wire assembly header    | 2   |
| 4-pin wire assembly header    | 1   |

## TOOLS NEEDED

---



### SOLDERING IRON

Temperature-adjustable is recommended. The optimum soldering temperature is 700-725° F (371-385° C) for leaded solder, or 750° F (400° C) for lead-free.

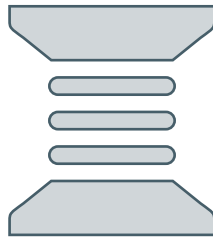

### SOLDER

Preferably 63/37 or 60/40 leaded solder. Lead-free is more difficult to use, so if that's the only type you can get, it's best to watch tutorials that are specific to lead-free solder.

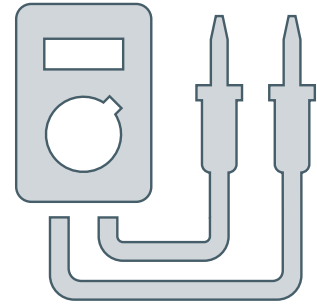

### DIGITAL MULTIMETER (DMM)

Most cheap ones in the \$10-30 range are fine for what we're doing. Make sure it has audible continuity testing (i.e. it beeps at the lowest resistance) and transistor hFE measurement.

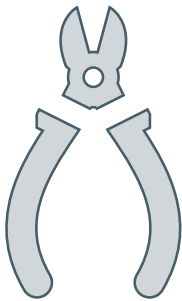

### WIRE SNIPPERS

Also called nippers or wire cutters. The Hakko CHP-170 is the best you can get for less than \$10.

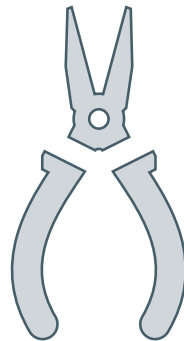

### FLAT-NOSE PLIERS

Many general-purpose uses, but particularly tightening the nuts of pots, switches and jacks. Quicker than changing out sockets on a ratchet.

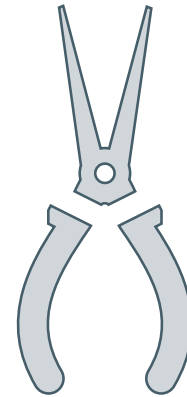

### NEEDLE-NOSE PLIERS

These are used for bending leads on components and other general uses. Use the smaller type with a tip that's approximately 0.05" (1.25mm) wide.

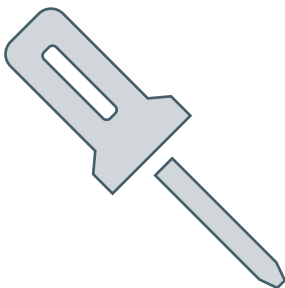

### SCREWDRIVER (PHILLIPS)

Used for the enclosure screws. Get a powered driver if you'll be building a lot of pedals!

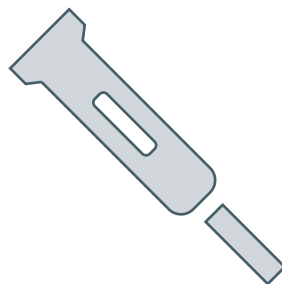

### FLAT SCREWDRIVER (SMALL)

This is used for tightening the set screws on the knobs. The tip should be no more than 0.1" (2.5mm) wide.

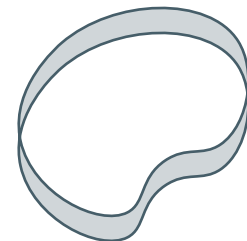

### RUBBER BAND

Yes, a plain old rubber band. This is used to tighten the dress nut to avoid scratching or denting it (which can happen with metal tools).

# COMPONENT IDENTIFICATION

If you've never built a pedal before, you'll need to know what all the components are. These are shown actual size. (Not all of these types of components may be part of this kit.)

## RESISTOR

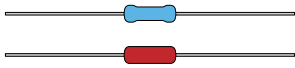

## TRIM POTENTIOMETER

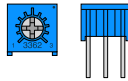

## LED

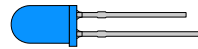

## SILICON DIODE



## GERMANIUM DIODE

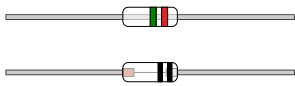

These are very fragile, so be careful when handling them.

## RECTIFIER DIODE



## SCHOTTKY DIODE



Some Schottky diodes also look like this.

## ZENER DIODE



## FILM CAPACITOR

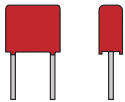

Not polarized. Color may vary by brand and type.

## ELECTROLYTIC CAPACITOR



Polarized. The negative side is marked.

## MLCC

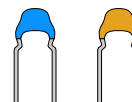

Not polarized. MLCC stands for "multi-layer ceramic capacitor."

## TANTALUM CAPACITOR



Polarized. The positive side is marked.

## IC OR OP-AMP



Charge pumps and delay chips also look like this. They may have more than 8 legs.

## IC SOCKET

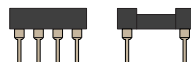

## TRANSISTOR OR JFET

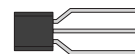

Some voltage regulators also look like this.

## TRANSISTOR WITH ADAPTER



The pins will be soldered to the adapter during kit assembly.

## WIRE ASSEMBLY



## WIRE ASSEMBLY HEADER

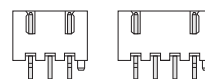

## DC JACK

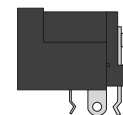





## LED BEZEL



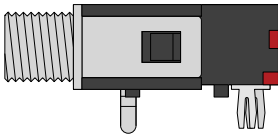
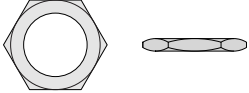
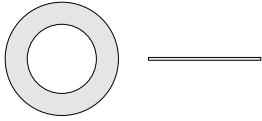
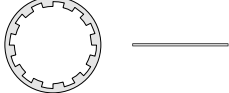

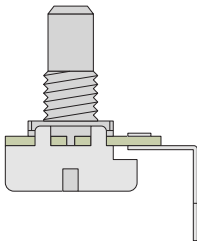
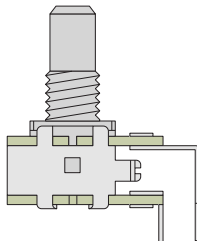
# HARDWARE IDENTIFICATION

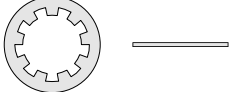
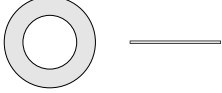
The hardware comes unassembled, so you'll need to sort & identify each of the pieces. The diagrams below are actual size, so you can set them against the printed page to identify them if needed.

|  |  |  |  |
|--|--|--|--|
| <p><b>I/O JACK</b></p>  | <p><b>MOUNTING NUT</b></p>  <p>DIAMETER: 0.54" / 13.7mm</p> | <p><b>OUTER WASHER</b></p>  <p>DIAMETER: 0.6" / 15.2mm</p> | <p><b>LOCK WASHER</b></p>  <p>DIAMETER: 0.5" / 12.7mm</p> |
|--|--|--|--|

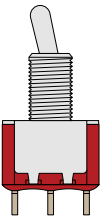
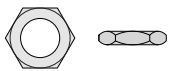
|  |  |   |  |
|--|--|---|--|
| <p><b>POTENTIOMETER (SINGLE)</b></p>  | <p><b>POTENTIOMETER (DUAL)</b></p>  | <p><b>MOUNTING NUT</b></p>  <p>DIAMETER: 0.44" / 11.2mm</p> | <p><b>LOCK WASHER</b></p>  <p>DIAMETER: 0.5" / 12.7mm</p> |
|  |  | <p><b>OUTER WASHER</b></p>  <p>DIAMETER: 0.475" / 12mm</p> | <p><b>KNOB</b></p>                                       |

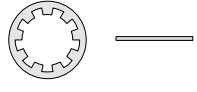
|   |   |  |  |
|---|---|--|--|
| <p><b>TOGGLE SWITCH</b></p>  | <p><b>MOUNTING NUT</b></p>  <p>DIAMETER: 0.36" / 9.1mm</p> | <p><b>DRESS NUT</b></p>  <p>DIAMETER: 0.375" / 9.5mm</p> | <p><b>LOCK WASHER</b></p>  <p>DIAMETER: 0.4" / 10.1mm</p> |
|---|---|--|--|

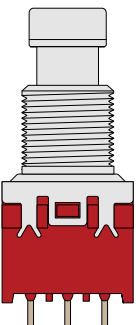
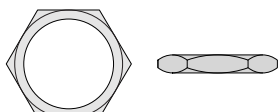
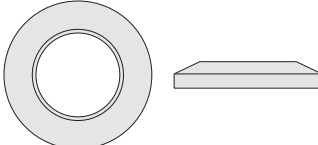
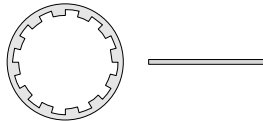
|  |   |  |  |
|--|---|--|--|
| <p><b>FOOTSWITCH</b></p>  | <p><b>MOUNTING NUT</b></p>  <p>DIAMETER: 0.6" / 15.2mm</p> | <p><b>DRESS NUT</b></p>  <p>DIAMETER: 0.77" / 19.6mm</p> | <p><b>LOCK WASHER</b></p>  <p>DIAMETER: 0.6" / 15.2mm</p> |
|--|---|--|--|



# PCB ASSEMBLY OVERVIEW

Now it's time to start building!

The first thing you need to do is snap apart the PCBs into 3 separate boards (if needed) and break off the tabs from each using needle-nose or flat-head pliers. You should be left with the PCBs shown to the right.

The general principle for PCB population is that you want to work in layers from shortest components (i.e. lowest-profile) to tallest so that when the PCB is upside-down, everything is making contact with the work surface and is held in place.

Generally speaking, you should populate the components in this order:

1. Resistors
2. Diodes
3. IC sockets
4. MLCC capacitors
5. Film capacitors
6. Transistors
7. Electrolytic capacitors

Not all of these component types are included in each kit, so skip them if they aren't applicable. Some types of film capacitors are taller than electrolytics, so those can be done last.

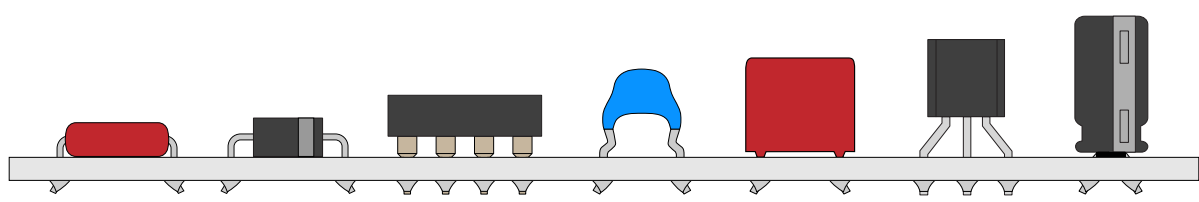
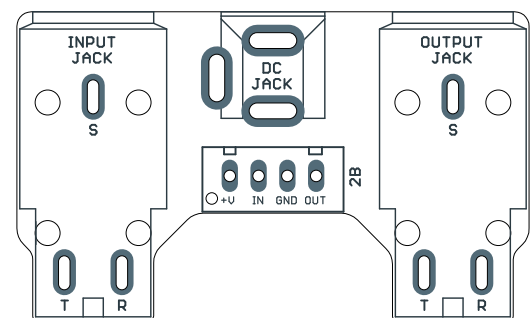
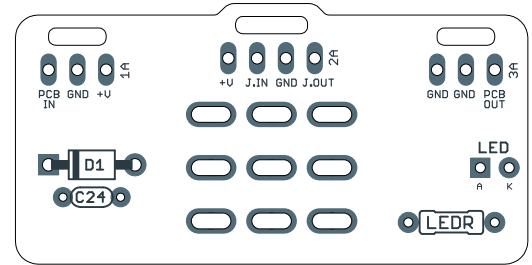
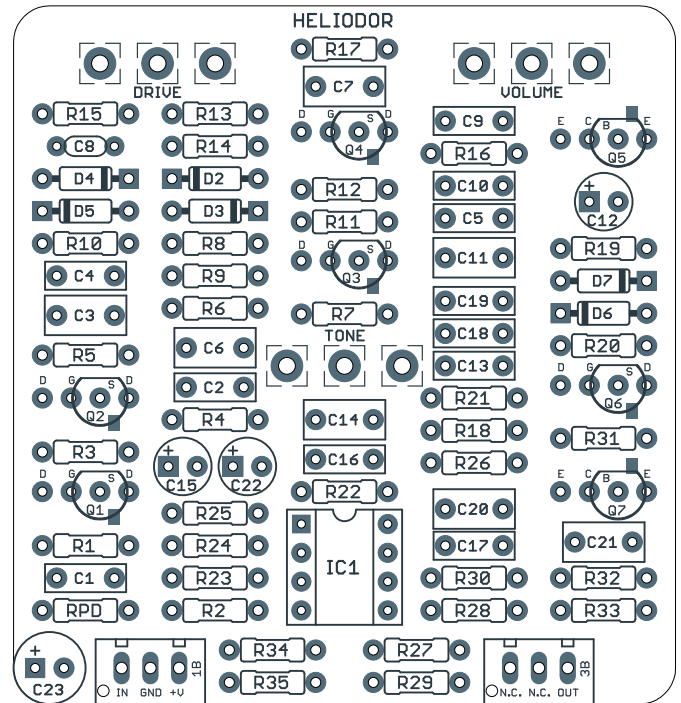

# RESISTORS

| PART | VALUE |
|------|-------|
| R1   | 10k   |
| R2   | 1M    |
| R3   | 10k   |
| R4   | 100k  |
| R5   | 10k   |
| R6   | 10k   |
| R7   | 3k3   |
| R8   | 10k   |
| R9   | 220k  |
| R10  | 220k  |

| PART | VALUE |
|------|-------|
| R11  | 2k7   |
| R12  | 6k8   |
| R13  | 470R  |
| R14  | 3k3   |
| R15  | 2k7   |
| R16  | 100k  |
| R17  | 33k   |
| R18  | 10k   |
| R19  | 1k    |
| R20  | 2k2   |

| PART | VALUE |
|------|-------|
| R21  | 4k7   |
| R22  | 47k   |
| R23  | 150k  |
| R24  | 1k    |
| R25  | 6k8   |
| R26  | 12k   |
| R27  | 4k7   |
| R28  | 12k   |
| R29  | 4k7   |
| R30  | 100k  |

| PART | VALUE |
|------|-------|
| R31  | 10k   |
| R32  | 100k  |
| R33  | 1k    |
| R34  | 10k   |
| R35  | 10k   |
| RPD  | 2M2   |
| LEDR | 22k   |

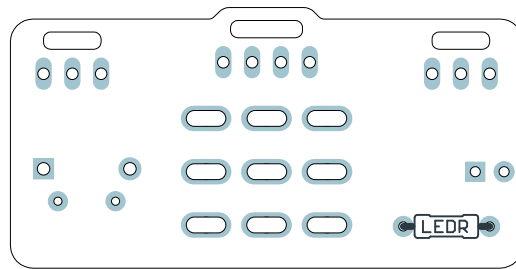
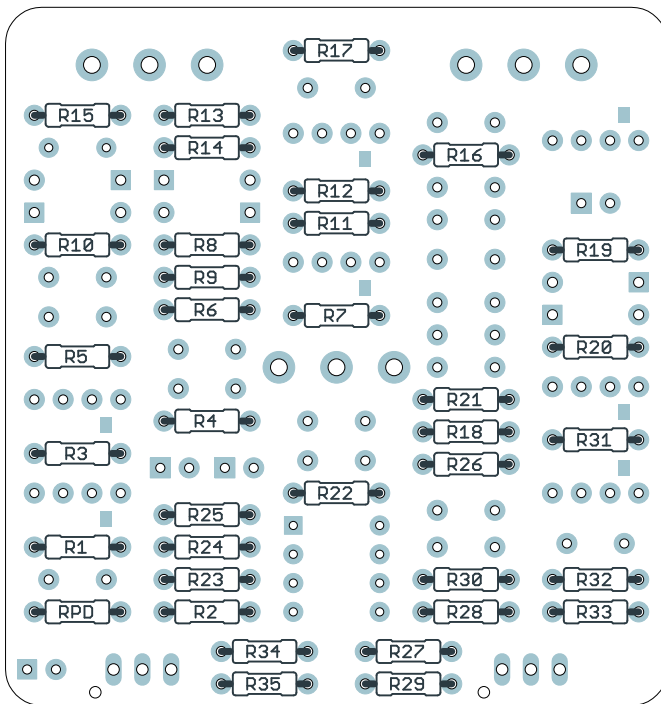

Using the parts list above, populate the resistors by pushing them through the holes and bending the leads outward at an angle to hold them in place. Resistors are not polarized, so they will work in any direction. Turn the board upside-down to keep the components held in place while you solder.

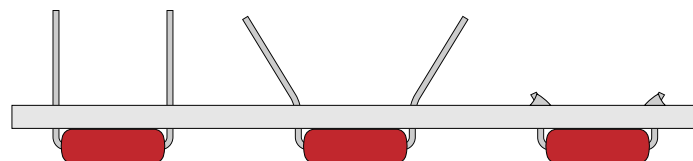

Don't try to do all of the resistors at once. You'll want to stop periodically flip the board and solder everything, then cut the leads using the wire snippers to make room for more.

# DIODES

| PART | VALUE  | PART | VALUE |
|------|--------|------|-------|
| D1   | 1N5817 | D5   | 1N914 |
| D2   | 1N914  | D6   | 1N914 |
| D3   | 1N914  | D7   | 1N914 |
| D4   | 1N914  |      |       |

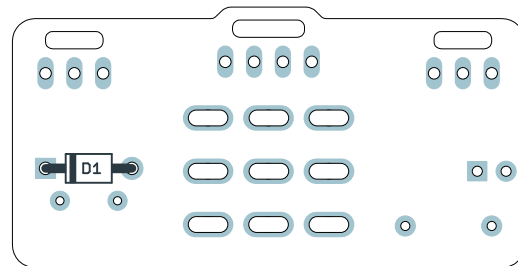
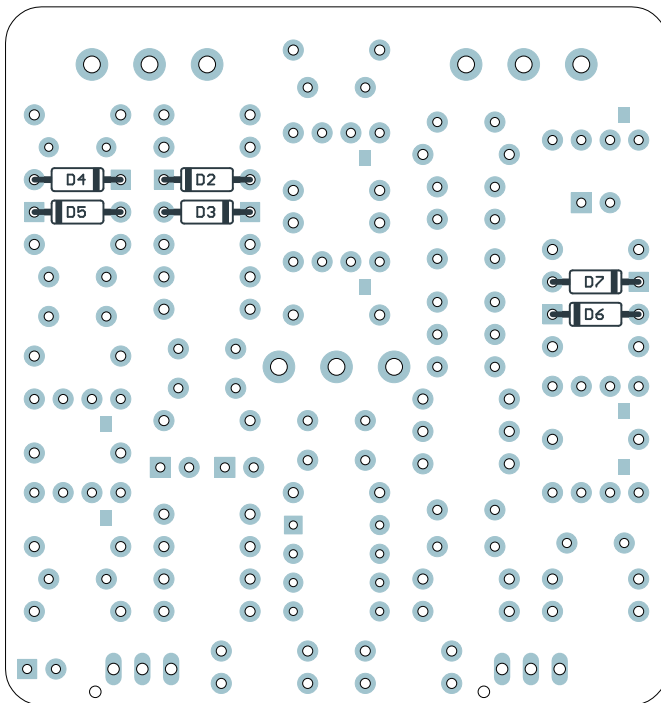

Next, you'll populate the diodes. Diodes are polarized, so make sure to identify the polarity band (which indicates the "cathode", or negative side) and match the band to the footprint on the PCB.

# SOCKET & IC

| PART | VALUE    |
|------|----------|
| IC1  | JRC4558D |

Next up is the IC socket. You can't bend the leads of the socket as with the other components, so it won't stay in on its own until it is soldered. Flip the PCB over and use gravity to hold it in place.

## Installing the IC

Don't insert the IC into the socket just yet. We will do this in a later step, after we've finished soldering the tallest components (the polarized capacitors). This information is just listed here for reference.

The legs of the IC are bent outward slightly during manufacturing, so they'll need to be bent back inward before they can be inserted into the sockets. It's easiest to do this by laying the IC legs against the table and bending the body itself so all four legs on the side are straightened out at once. Then, flip it and do the other side.

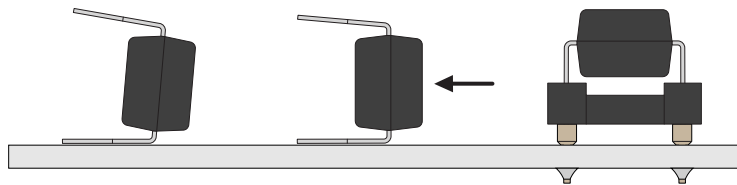
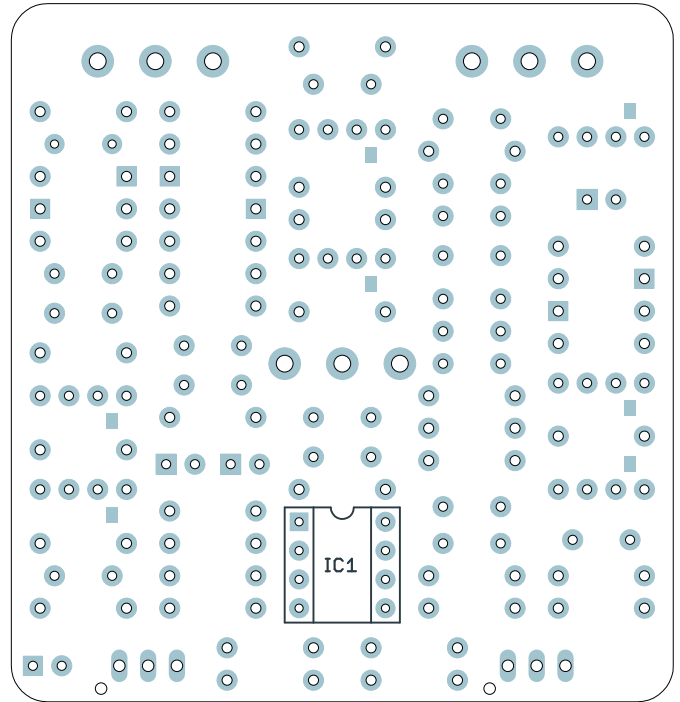

ICs may have two different orientation marks: either a dot in the upper-left or a half-circle notch in the middle of the top side. Some ICs have both marks. This shows which way the IC should be rotated when inserting it into a socket (the socket also has a half-circle notch).

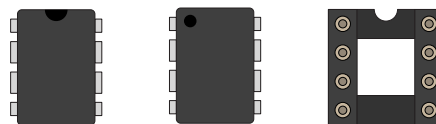

# TRANSISTORS

| PART | VALUE  |
|------|--------|
| Q5   | 2N3906 |
| Q7   | 2N5088 |

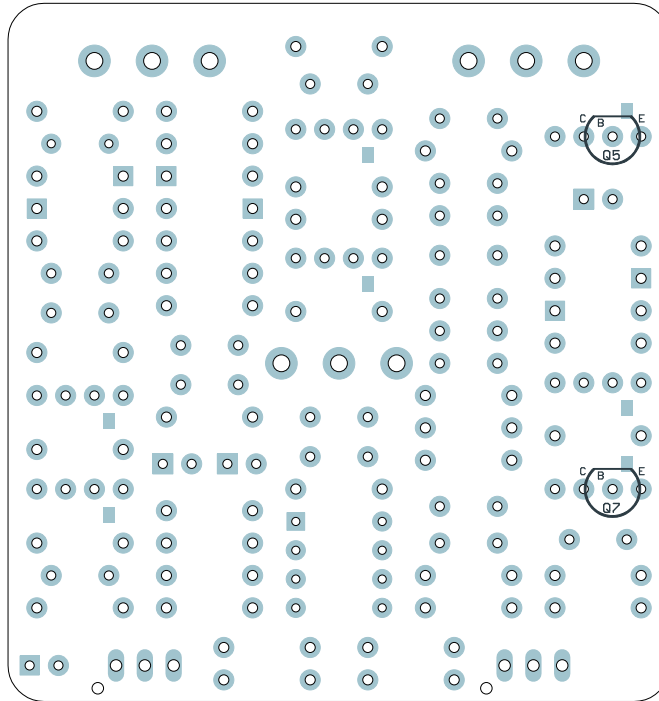

Now we'll do the two transistors. For each, if the legs are not already bent into 0.1" spacing, use your needle-nose pliers to bend the outer two legs as shown.

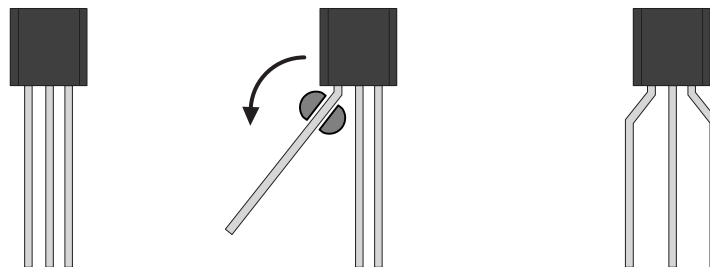

Once installed, bend the two outer legs to hold it in place on the board. Then, solder them in place and clip the leads.

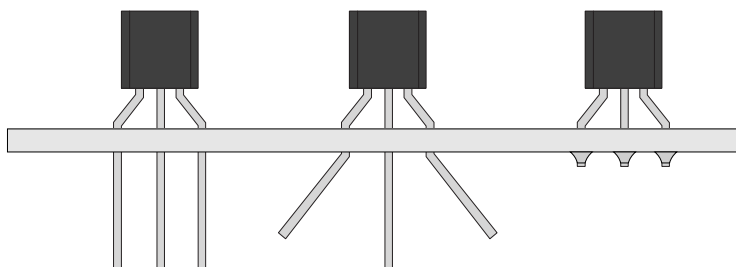

Note that there is an extra "E" pad next to each transistor outline. These are only used for NOS Japanese transistors with different pinouts and should be ignored for the kit build. Install each transistor as shown in the silkscreen on the PCB.

# JFETS

| PART | VALUE     |
|------|-----------|
| Q1   | 2SK209-GR |
| Q2   | 2SK209-GR |
| Q3   | 2SK209-GR |
| Q4   | 2SK209-GR |
| Q6   | 2SK209-GR |

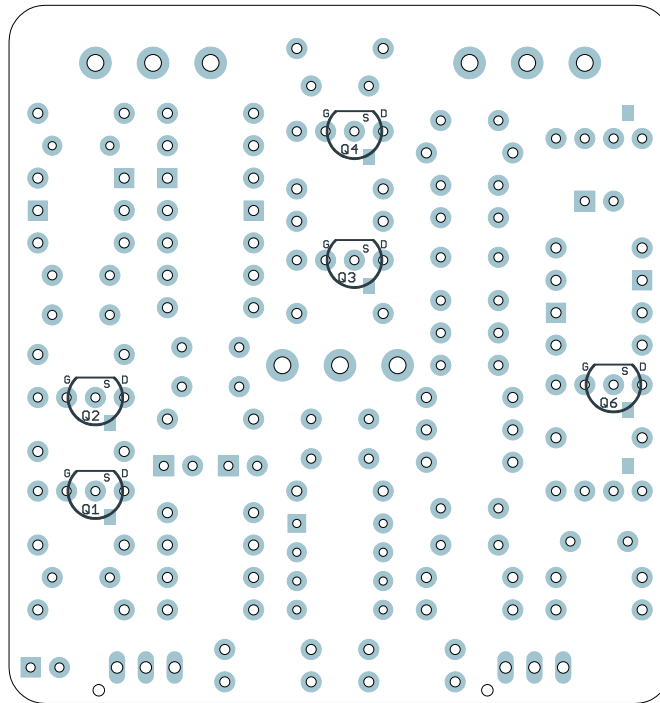

Now we'll do the five JFET transistors. The PCB outline shows through-hole TO-92 outlines, but the through-hole 2SK209 has been discontinued for many years.

We use current-production surface-mount JFETs which perform identically to those used in the original Boss pedal. These are mounted to adapter boards so they can be used in through-hole designs such as this one. However, this does require some extra work since the legs must be soldered to the adapter.

## STEP 1

Break apart the adapter PCBs (you can just use your fingers for this) and then use pliers to snap off the tabs.

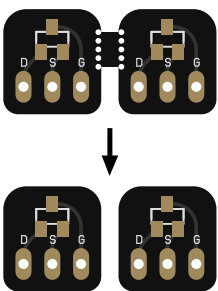

## STEP 2

Using wire cutters, cut the pin strip into two sets of three. Separate the top panel from the pin strip by bending it back.

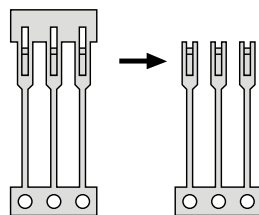

## STEP 3

Clip the pins to the adapter, making sure they're centered on the pads and pushed up all the way.

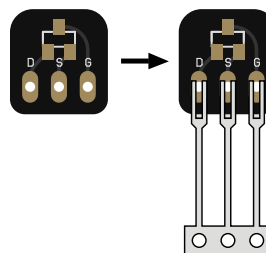

## STEP 4

Solder the pins (including the reverse side, if needed). Then, using wire cutters, clip the bottom strip from the pins.

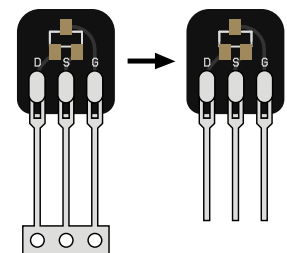

Once the pins are installed, the JFETs can be soldered to the PCB like any other normal component.

**Be very careful to line up the D-S-G labels with the markings on the PCB or the effect will not work.** The component side of the PCB adapter should face toward the top of the PCB.

As with the transistors, there is an extra "D" pad to the left of each JFET which is not used in the kit build.

## CAPACITORS (NON-POLARIZED)

| PART | VALUE    |
|------|----------|
| C1   | 47n film |
| C2   | 18n film |
| C3   | 1uF film |
| C4   | 10n film |
| C5   | 56n film |

| PART | VALUE     |
|------|-----------|
| C6   | 1uF film  |
| C7   | 470n film |
| C8   | 47pF MLCC |
| C9   | 56n film  |
| C10  | 1n2 film  |

| PART | VALUE     |
|------|-----------|
| C11  | 470n film |
| C13  | 12n film  |
| C14  | 1uF film  |
| C16  | 6n8 film  |
| C17  | 18n film  |

| PART | VALUE     |
|------|-----------|
| C18  | 33n film  |
| C19  | 22n film  |
| C20  | 1uF film  |
| C21  | 1uF film  |
| C24  | 100n MLCC |

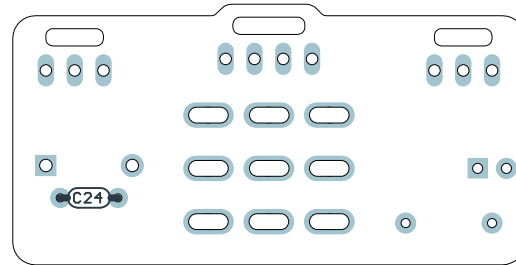
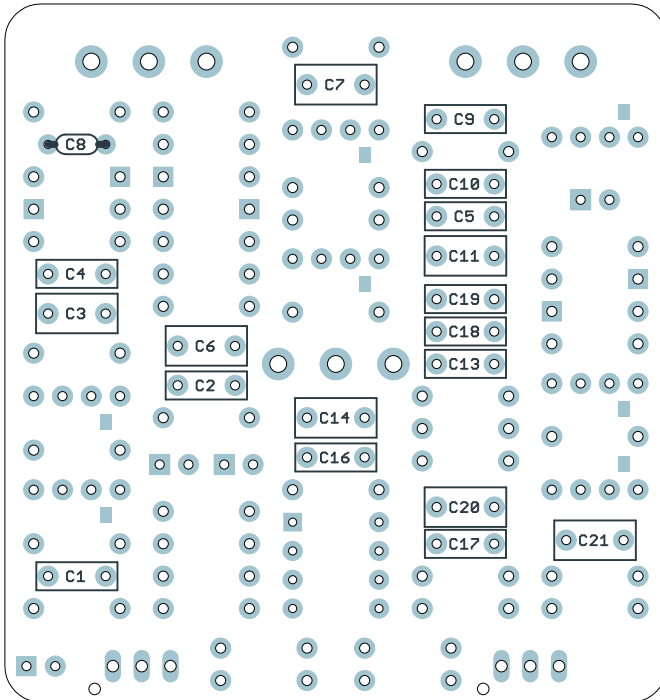

After the sockets come the box film and MLCC capacitors. These are all several different heights, so it's recommended to do the taller 1uF capacitors last. Bend the leads at an angle to hold them in place.

MLCCs and box capacitors are not polarized, so they will work in any direction, but to keep things neat, it's best to put them all facing the same way.

**Note:** C10 and C13 are usually blue box-film capacitors. For these, the value is printed on the top rather than the side.

C8 is a blue MLCC taped to cardboard. C24 (100n MLCC) is always yellow. It can be hard to read the code since it's so small, so it's easier to identify these two by color.

## WIRE HEADERS

---

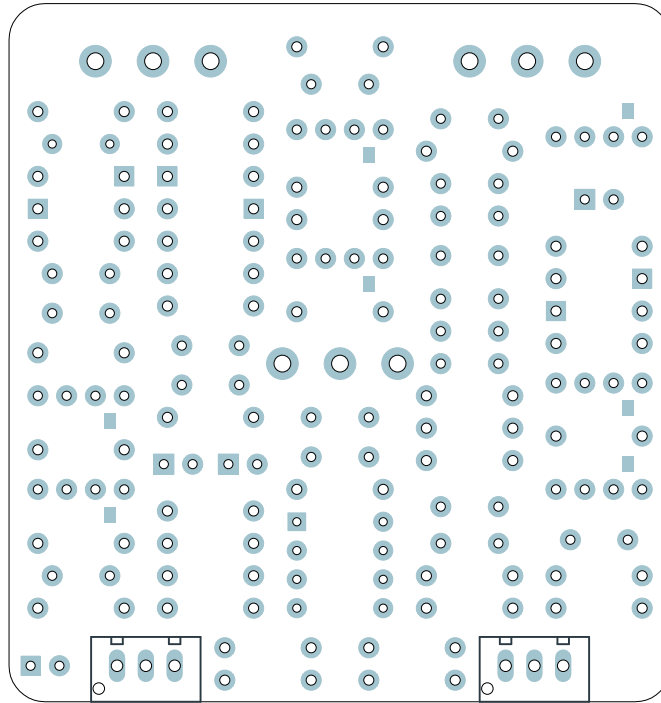

Install the two 3-pin headers (wire connectors) as shown above. These have a polarity pin, so as long as they are pressed all the way down, there's only one possible way to install them. They do fit pretty tightly in the holes, though, so press firmly.

There's also a 4-pin header on the I/O board that we will do in a later step.



# CAPACITORS (POLARIZED)

| PART | VALUE |
|------|-------|
| C12  | 10uF  |
| C15  | 10uF  |
| C22  | 47uF  |
| C23  | 100uF |

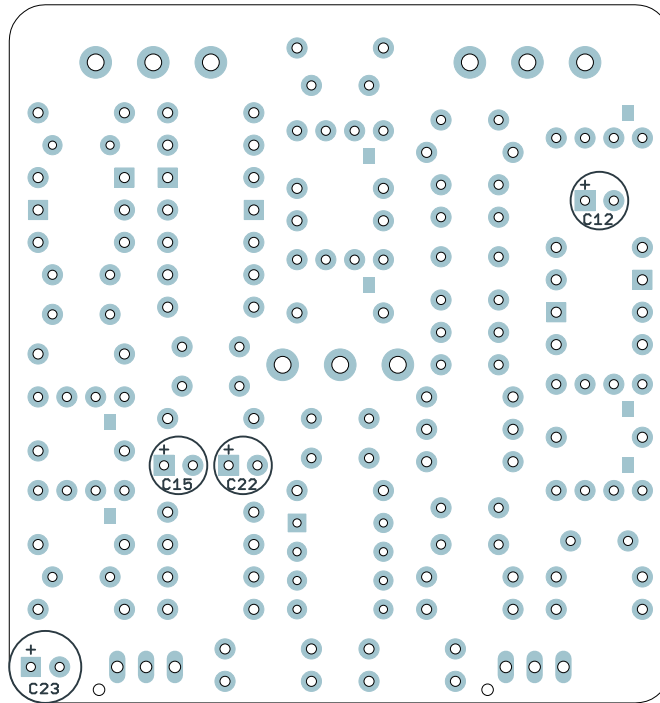

Populate the electrolytic capacitors. These are the tallest components, so we save them for last. They are polarized (i.e. they will only work in one direction), so note the vertical mark that indicates the negative side. The longer leg is positive and fits in the square pad.

These are the last of the on-board components. Now is the time to go back to page 12 and insert the IC into the socket.

# FOOTSWITCH PCB

## PARTS

3-strand wire assembly (2)

4-strand wire assembly

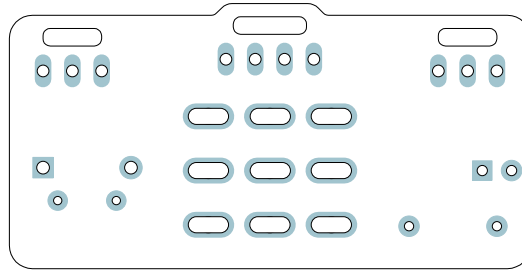

Next, it's time to finish up the footswitch board. You should have done most of the on-board components on this board in a previous step, but if not, go back and do those.

There will be one longer assembly with 4 wires and two shorter ones with 3 wires. The longer one goes in the middle and the shorter ones go on the left and right sides. The wire assemblies should then be soldered to the footswitch board as shown.

### STEP 1

First, thread the wire through the strain-relief slots, with the blue side facing outward and the PCB's previously-installed components facing up.

For now, pull it through as far as it can go.

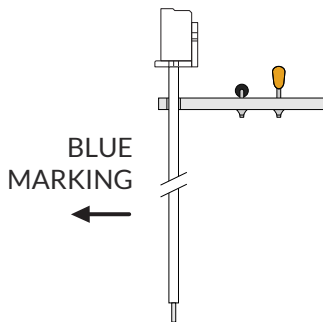

### STEP 2

Next, bend the wires back upward and fit the ends of the wires into the solder pads.

On the top side of the PCB, bend the exposed wires backward so it holds the wire in place. Pull the header back up through the slot partway.

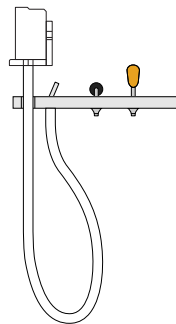

### STEP 3

Then, solder the wires from the top. This is the trickiest part of the whole build. You want to solder the pads without touching the iron to the wires themselves and risking burning through the insulation. It helps to use a sharp or narrow tip on the soldering iron.

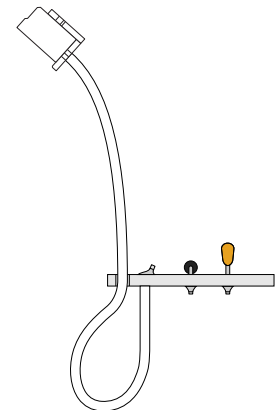

Once all three wire assemblies are soldered, set the footswitch PCB aside. We'll solder the actual footswitch and LED in a later step.

# INPUT/OUTPUT PCB

## PARTS

Input & output jacks

DC jack

Wire header

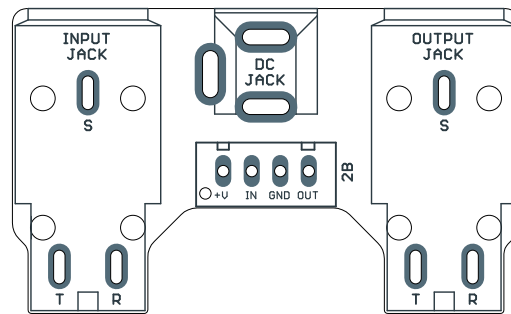

Almost done! Get the two input/output jacks, the DC jack and the wire header and snap them in place. The PCB is designed for them to fit securely, so you can do them all at once before flipping and soldering.

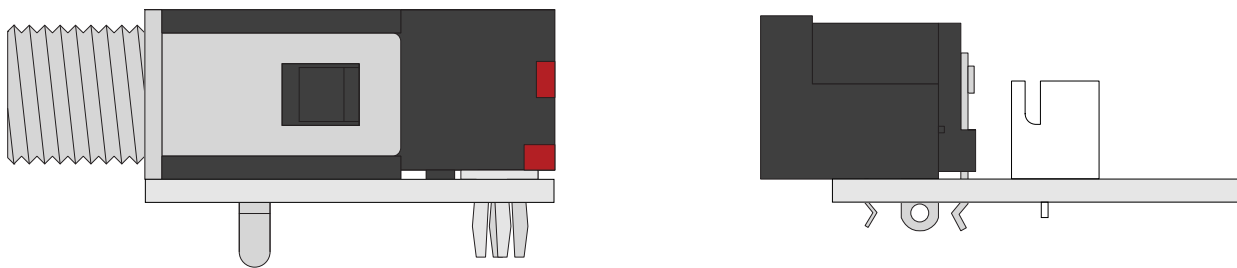

After you've soldered everything, make sure to **snip the leads on the I/O jacks as close as possible to the PCB**. There's not a lot of clearance between the bottom of this board and the top of the main PCB once everything is in place, and you don't want the pins to short against anything on accident.

# ENCLOSURE LAYOUT: PANEL MOUNTS

Attach the hardware to the enclosure as shown. (The I/O board is done in a later step.)

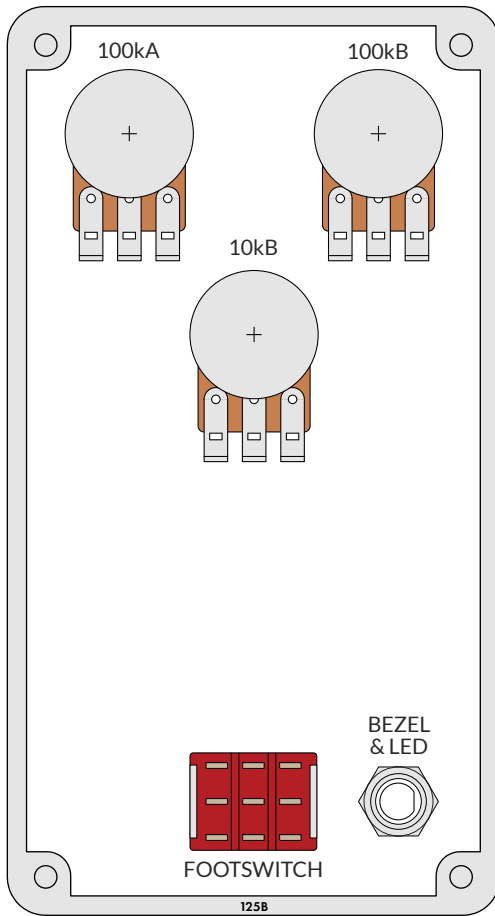

## FOOTSWITCH

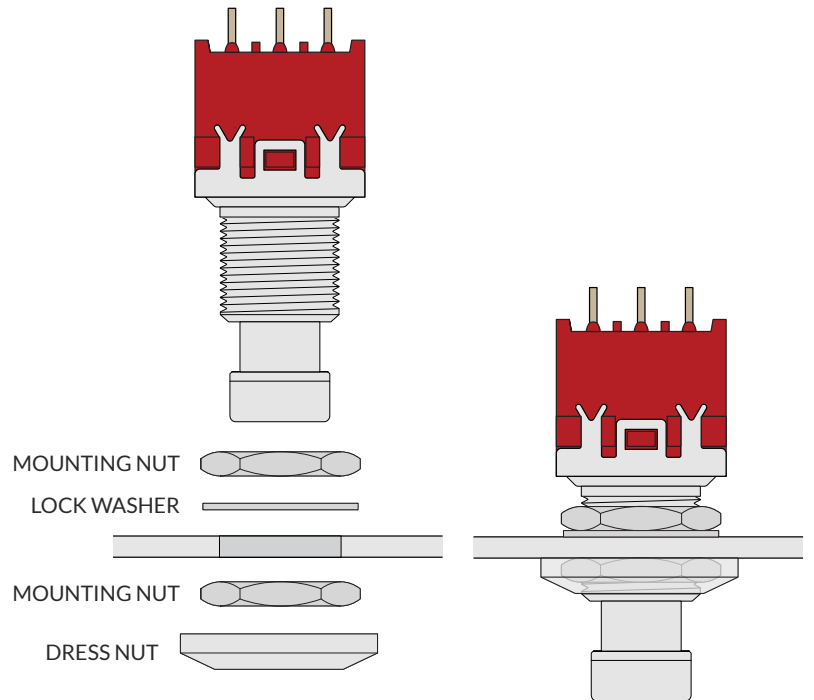

The dress nut fits over the top of the mounting nut and is for aesthetic purposes only. Wrap a rubber band around it to use as a grip when tightening. Avoid using metal tools on it or you run the risk of scratching or denting it.

## POTENTIOMETERS

Drive: 100kA

Tone: 10kB

Volume: 100kB

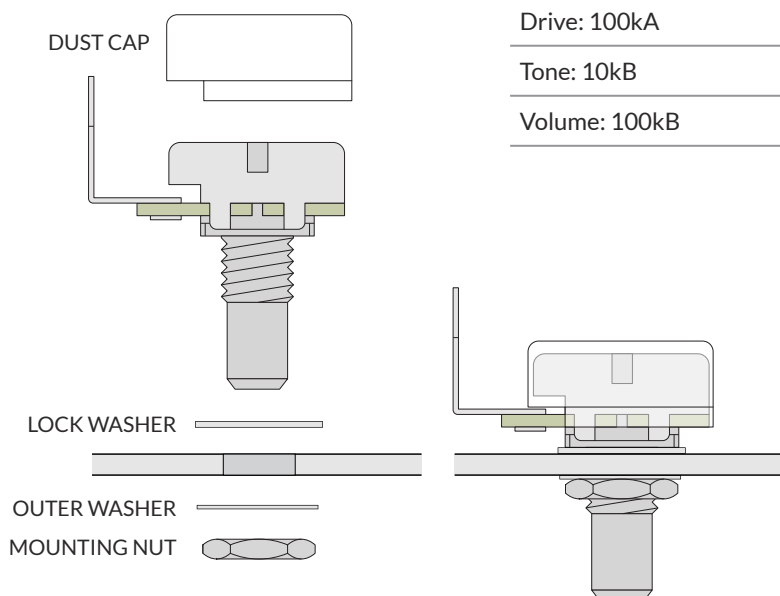

## BEZEL & LED

The LED will just sit loosely inside the bezel for now.

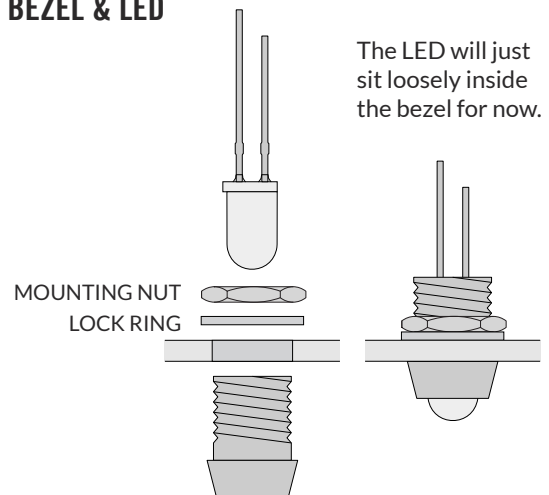

You'll need to hold the bezel in place when tightening the nut. Be aware that the bezel is fairly sharp. Try using a rubber band for grip instead of just pressing your finger against the bottom.

## ENCLOSURE LAYOUT: MAIN & FOOTSWITCH PCBs

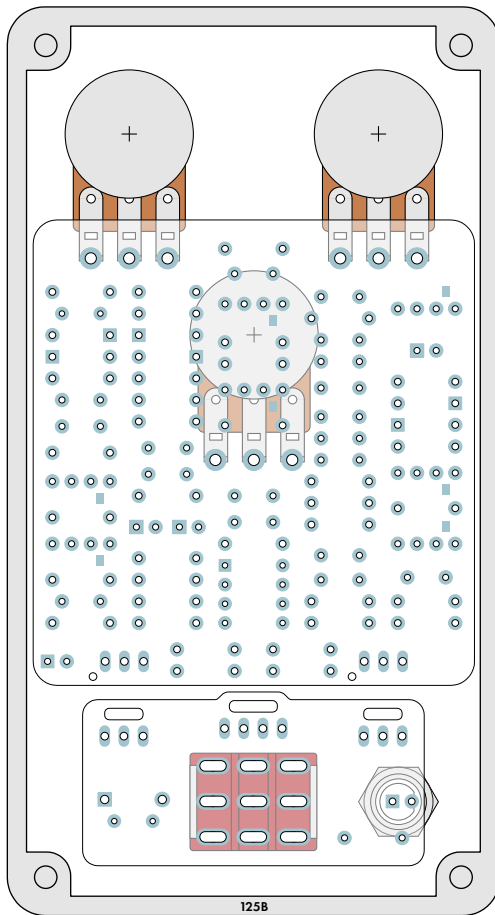

After all the components are affixed to the enclosure as shown on the previous page, place the main PCB on top of the potentiometers as in the diagram to the left.

You may need to adjust the position of the potentiometers slightly if they are not aligned straight.

Once all of the pins are through and the PCB is laying flat, solder each of the pins from the top, being careful not to touch any of the surrounding components with the soldering iron.

After you've finished soldering the pots, **clip the leads as close as you can to the main PCB**. This is important because the input/output PCB overlaps them and you need to avoid any of the components shorting.

Next, do the same thing with the footswitch board—the 3PDT footswitch and the LED.

Before soldering, double-check to **make sure the flat side of the LED is facing to the right**, as shown in the diagram, and that the short leg is coming through the pad on the right. It won't work if it's turned the other way.

### Why solder everything inside the enclosure before testing it?

“Rock it before you box it” is conventional wisdom in pedalbuilding, and you'll often hear it recommended that builders should test the circuit before putting everything inside the enclosure. However, Aion FX projects are designed to be extremely easy to remove from the enclosure for troubleshooting, with no desoldering required—so with these kits, it's actually much easier to “box it before you rock it”.

If you've read the documentation carefully and followed all the instructions, there's a good chance you will get it right the first time!

# ENCLOSURE LAYOUT: INPUT/OUTPUT PCB

Affix the input/output PCB to the north-facing panel of the enclosure as shown.

Note the use of two mounting nuts on each of the jacks, one inside and one outside. The inner nut acts as a spacer to set the DC jack flush with the outside of the enclosure. The inner nuts should be threaded as far down as they can go.

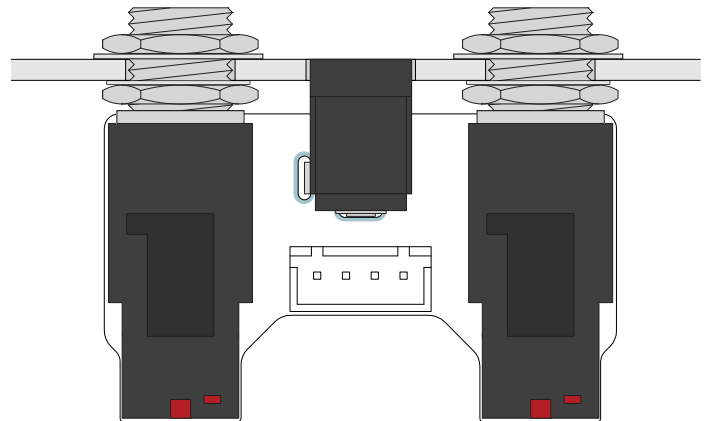
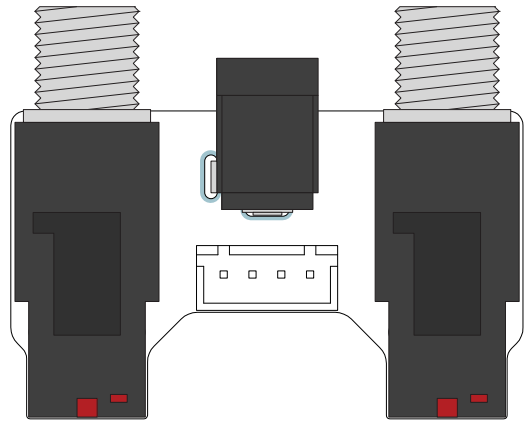
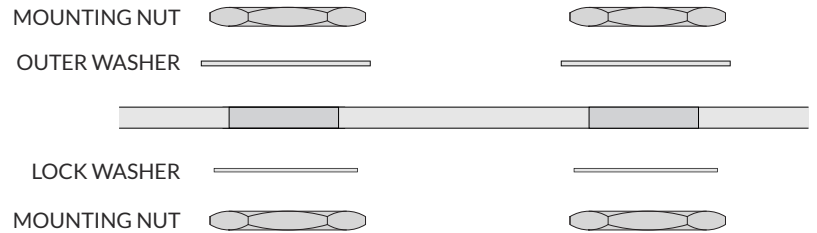
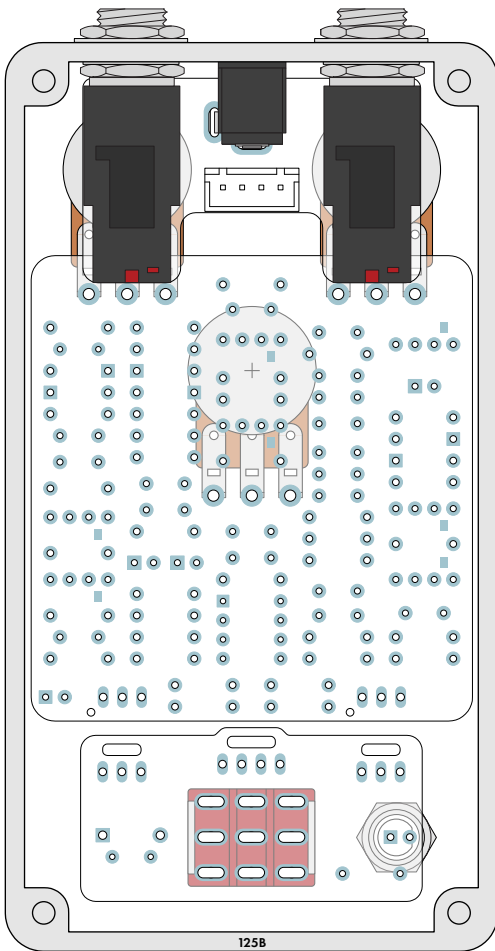

## FINAL TESTING & ASSEMBLY

After everything is in place, just plug the 3 wire assemblies into their respective headers and make sure they're secure. That's it! Here is a cross-section of the inside of the completed pedal.

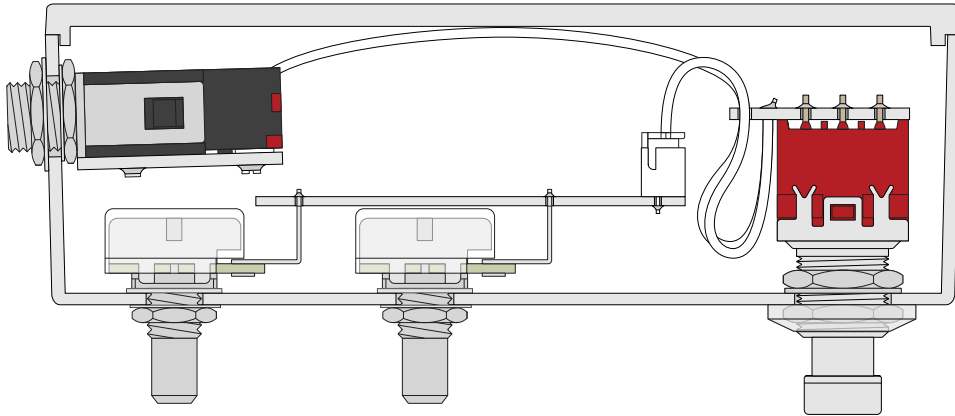

At this point, you have completed the full circuit as far as the electrons are concerned. Plug in a 9-volt supply and test it out with a guitar and an amplifier.

Test the bypass switch a few times, then start turning the knobs and see if everything sounds OK. If it works, great! If not, don't be discouraged. See page 26 for troubleshooting info.

### Finishing touches

Now, just a couple of things for the final assembly. Turn the shafts all fully counter-clockwise, then put on the knob and rotate until the indicator line is aligned with the dot on the enclosure that shows the zero point. Affix the knobs to each of the potentiometer shafts as shown in the diagram below.

Using a small flat-head screwdriver (no more than 0.1" / 2.5mm in diameter), tighten the set screw until it presses against the shaft of the potentiometer and holds the knob in place.

Don't over-tighten or you could damage the set screw. But on the other hand, if it's not tight enough then the knob will be prone to falling off or losing its alignment with the markings on the enclosure.

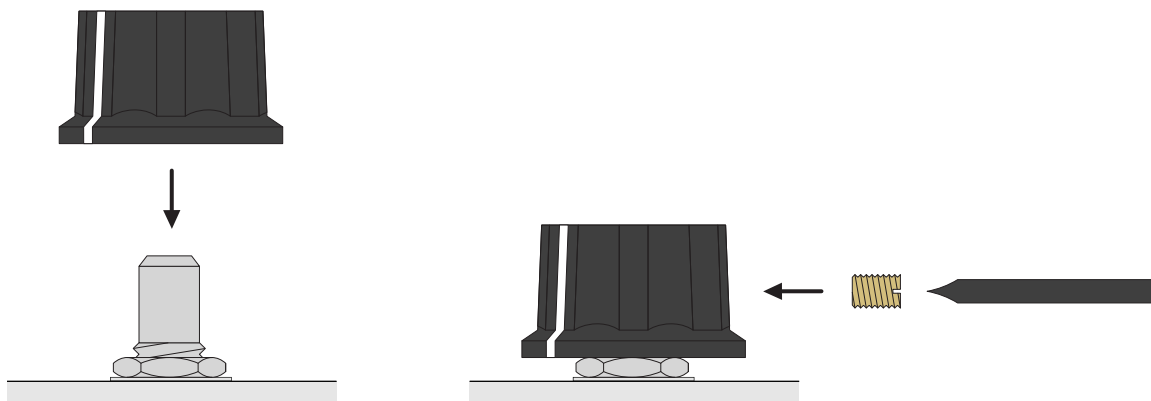

Last, just close the panel on the back using the four screws. Before that, though, grab a permanent marker and write your name and the completion date on the inside of the back panel. This is an accomplishment!

# SCHEMATIC

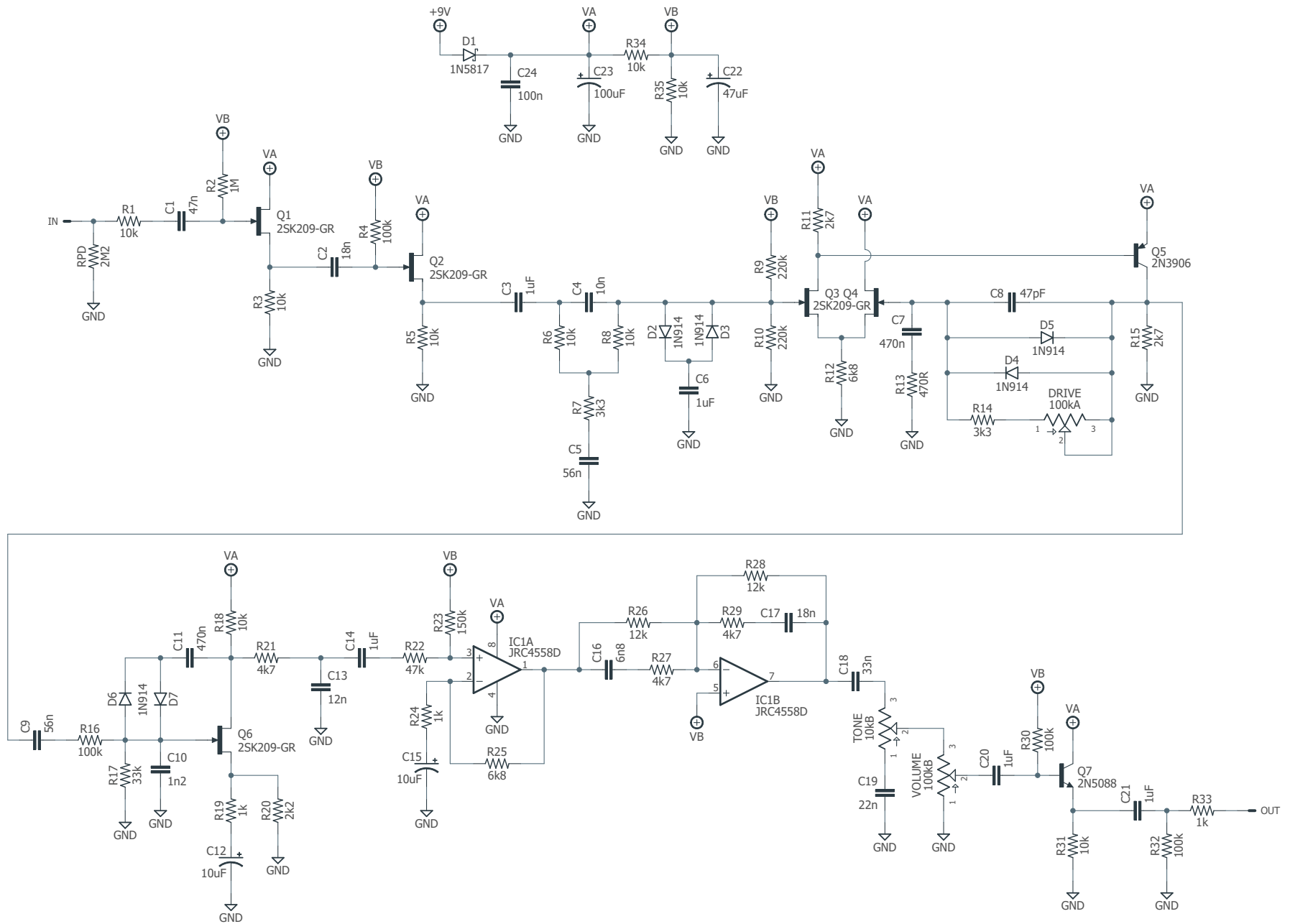



# FULL PARTS LIST

---

In this document, the parts list is spread out across several pages by step. For more experienced builders, though, it may be easier to have everything in one place.

## Resistors

| PART | VALUE |
|------|-------|
| R1   | 10k   |
| R2   | 1M    |
| R3   | 10k   |
| R4   | 100k  |
| R5   | 10k   |
| R6   | 10k   |
| R7   | 3k3   |
| R8   | 10k   |
| R9   | 220k  |
| R10  | 220k  |

| PART | VALUE |
|------|-------|
| R11  | 2k7   |
| R12  | 6k8   |
| R13  | 470R  |
| R14  | 3k3   |
| R15  | 2k7   |
| R16  | 100k  |
| R17  | 33k   |
| R18  | 10k   |
| R19  | 1k    |

| PART | VALUE |
|------|-------|
| R20  | 2k2   |
| R21  | 4k7   |
| R22  | 47k   |
| R23  | 150k  |
| R24  | 1k    |
| R25  | 6k8   |
| R26  | 12k   |
| R27  | 4k7   |
| R28  | 12k   |

| PART | VALUE |
|------|-------|
| R29  | 4k7   |
| R30  | 100k  |
| R31  | 10k   |
| R32  | 100k  |
| R33  | 1k    |
| R34  | 10k   |
| R35  | 10k   |
| RPD  | 2M2   |
| LEDR | 22k   |

## Capacitors

| PART | VALUE     |
|------|-----------|
| C1   | 47n film  |
| C2   | 18n film  |
| C3   | 1uF film  |
| C4   | 10n film  |
| C5   | 56n film  |
| C6   | 1uF film  |
| C7   | 470n film |
| C8   | 47pF MLCC |

| PART | VALUE        |
|------|--------------|
| C9   | 56n film     |
| C10  | 1n2 film     |
| C11  | 470n film    |
| C12  | 10uF electro |
| C13  | 12n film     |
| C14  | 1uF film     |
| C15  | 10uF electro |
| C16  | 6n8 film     |

| PART | VALUE         |
|------|---------------|
| C17  | 18n film      |
| C18  | 33n film      |
| C19  | 22n film      |
| C20  | 1uF film      |
| C21  | 1uF film      |
| C22  | 47uF electro  |
| C23  | 100uF electro |
| C24  | 100n MLCC     |

## Transistors

| PART | VALUE     |
|------|-----------|
| Q1   | 2SK209-GR |
| Q2   | 2SK209-GR |
| Q3   | 2SK209-GR |
| Q4   | 2SK209-GR |
| Q5   | 2N3906    |
| Q6   | 2SK209-GR |
| Q7   | 2N5088    |

## IC

| PART         | VALUE    |
|--------------|----------|
| IC1          | JRC4558D |
| 8-pin socket |          |

## Diodes

| PART  | VALUE  |
|-------|--------|
| D1    | 1N5817 |
| D2-D7 | 1N914  |

## Potentiometers

| PART   | VALUE |
|--------|-------|
| Drive  | 100kA |
| Tone   | 10kB  |
| Volume | 100kB |

## Switches

| PART       | VALUE |
|------------|-------|
| 3PDT stomp |       |

# TROUBLESHOOTING INFORMATION

If you finish building the kit and find that it doesn't work right, we've written a separate in-depth [Troubleshooting Guide](#) that applies to all of our kits. The main troubleshooting process is covered there. Here you will find information specific to this kit that will help with that process.

## Voltages

The following voltages are taken from our prototype unit using a **9.6V** supply. Your measured voltages won't be exactly the same due to variance in power supplies and component tolerances. However, if you see anything more than +/-0.5V from the listed voltages, it's a good indicator of an issue, and the exact voltages can help narrow it down.

Note that IC pins are labeled counter-clockwise from the upper-left, as shown in the diagram to the right. Transistors and JFETs have their pins labeled on the PCB.

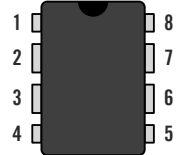

### IC1

| PIN | VOLTAGE |
|-----|---------|
| 1   | 4.65    |
| 2   | 4.65    |
| 3   | 4.60    |
| 4   | 0       |
| 5   | 4.64    |
| 6   | 4.65    |
| 7   | 4.64    |
| 8   | 9.40    |

### Q1

| PIN | VOLTAGE |
|-----|---------|
| G   | 4.24    |
| S   | 4.95    |
| D   | 9.40    |

### Q2

| PIN | VOLTAGE |
|-----|---------|
| G   | 4.59    |
| S   | 4.94    |
| D   | 9.40    |

### Q3

| PIN | VOLTAGE |
|-----|---------|
| G   | 2.31    |
| S   | 2.67    |
| D   | 8.75    |

### Q4

| PIN | VOLTAGE |
|-----|---------|
| G   | 2.30    |
| S   | 2.67    |
| D   | 9.40    |

### Q5

| PIN | VOLTAGE |
|-----|---------|
| C   | 2.30    |
| B   | 8.75    |
| E   | 9.40    |

### Q6

| PIN | VOLTAGE |
|-----|---------|
| G   | 0       |
| S   | 0.36    |
| D   | 7.73    |

### Q7

| PIN | VOLTAGE |
|-----|---------|
| C   | 9.40    |
| B   | 4.52    |
| E   | 3.96    |

## SUPPORT

---

**Aion FX does not offer direct support for these projects beyond the provided documentation.**

Replacements and refunds cannot be offered unless it can be shown that the circuit or documentation are in error or that the included components are non-functional.

### Where to get help

The two best places to ask for help are the [DIY Stompboxes forum](#) and the [DIY Stompboxes Facebook group](#). Both communities have thousands upon thousands of members and they are very accommodating to new builders.

When posting a troubleshooting request, always include the following:

1. A thorough description of the problem you are experiencing
2. A photo of the inside of the pedal
3. A list of all the measured voltages of each of the pins, described on the previous page

While we cannot offer direct, private support, you may send a link to your public troubleshooting thread to Aion FX using the contact form on the website. There is no guarantee that we will be able to join the discussion and help solve your problem, but this improves the chances.

It benefits the whole community if the troubleshooting process is public because then people who have the same issue in the future may come across it when searching. And if you do get help, remember to pay it forward! The best way to learn new skills is to help others. Even if you've only built one pedal, you have more experience than someone who is brand new, so you have something to offer.

## RESALE TERMS

---

These kits may be used for commercial endeavors in any quantity unless otherwise noted. It's okay to sell individual builds locally or online, or even to offer a service to build pedals based on these kits.

No direct attribution is necessary, though a link back is always greatly appreciated. The only usage restriction is that you cannot "goop" the PCB or otherwise obscure the source. In other words: you don't have to go out of your way to advertise the fact that you use Aion FX kits, but please don't go out of your way to hide it. The guitar effects industry needs more transparency, not less!

## LEGAL INFORMATION

---

BOSS® is a registered trademark of Roland Corporation.

All other trademarks are property of their respective owners.

Any use of trademarks is for comparative advertising purposes only under fair use. It is not an endorsement of this product by the trademark holders.

These kits are intended to be built by the customer. Aion FX is not responsible for language that may be used by the customer in the marketing or resale of the finished product.

All content and graphics in this document are original works and are copyrighted by Aion FX and may not be used without permission.

## DOCUMENT REVISIONS

---

1.0.0 (2024-06-01)

Initial release.