

PROJECT NAME

HALO

BASED ON

Electro-Harmonix Big Muff Pi

BUILD DIFFICULTY

■■■■■ Easy

EFFECT TYPE

Distortion / Sustainer, Fuzz

DOCUMENT VERSION

2.1.1 (2026-02-XX)

QION
DIY GUITAR EFFECTS

PROJECT SUMMARY

One of the most classic guitar effects of all time, its sound falls somewhere between a distortion effect and a fuzz with an incredibly long sustain.

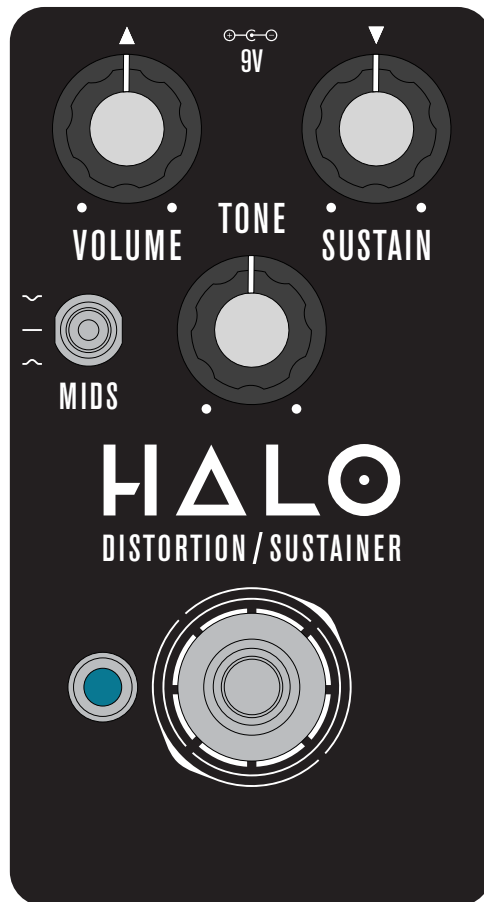

IMPORTANT NOTE

This documentation is for the **kit** version of the project. If you purchased the PCB by itself, please use the [PCB-only version](#) of the documentation instead. The circuit is the same, but the instructions are completely different due to the specialized parts and assembly methods used in the kit.

Additionally, as of February 2026, this kit is available in 3 variants. The bag of resistors & capacitors is color-coded to indicate which variant you have. If your kit does not have a color-coded component bag, please use the earlier version of the build document.

TABLE OF CONTENTS

- 1 Project Overview
- 2 Table of Contents
- 3 Introduction
- 4 Packing List (variations)
- 5 Packing List (all versions)
- 6 Tools Needed
- 7 Component Identification
- 8 Hardware Identification
- 9 PCB Assembly Overview
- 10 Kit Variants
- 11 Resistors Overview
- 12 Resistors (Triangle)
- 13 Resistors (Violet Ram's Head)
- 14 Resistors (Gilmour)
- 15 Resistors (Civil War)
- 16 Diodes
- 17 Transistors
- 18 Capacitor Identification
- 19 Capacitors (Non-Polarized)
- 20 Wire Headers
- 21 Capacitors (Polarized)
- 22 Footswitch PCB
- 23 Input/Output PCB
- 24 Enclosure Layout: Panel Mounts
- 25 Enclosure Layout: Panel Mounts (cont.)
- 26 Enclosure Layout: Main & Footswitch PCBs
- 27 Enclosure Layout: Input/Output PCB
- 28 Final Testing & Assembly
- 29 Schematic (Triangle)
- 30 Schematic (Violet Ram's Head)
- 31 Schematic (Gilmour)
- 32 Schematic (Civil War)
- 33 Full Parts List
- 34 Full Parts List (cont.)
- 35 Troubleshooting Information
- 36 Support & Resale Terms
- 37 Legal Information & Document Revisions

INTRODUCTION

If this is your first pedal, welcome to the hobby and thank you for choosing Aion FX. You've just joined a community of over 100,000 people around the world with a passion for building homemade noise machines using obsolete electronics technology, and we're glad to have you!

If you've done this before, it's great to see you again and we're confident you'll find this build experience an enjoyable one.

Aion FX kits are designed to empower anyone to build a high-quality pedal, no matter the skill level. The pedalbuilding hobby has traditionally had a steep learning curve, but don't be overwhelmed—we've done all the hard work for you. All you need to do is follow these instructions and you'll be on your way to transforming your tone.

There are a few things to go over before you get started.

- **You're going to have to get your hands dirty**—there's no way around it. Nothing here comes preassembled, and you'll have to learn the skills to put it all together. This document will walk you through everything you need, but be prepared to learn a few things along the way.
- **This will take time.** Plan on about two hours start to finish. It may take even longer if it's your first time building. Don't rush it. If you find yourself getting frustrated or overwhelmed, take a break and come back in a couple of hours or the next day.
- **No direct technical support is offered.** There are several DIY forums and Facebook groups with thousands of members who enjoy troubleshooting and teaching. But please be sensitive to the fact that the staff at Aion FX is minimal, and every minute spent helping individuals in private is time that can't be spent on new project development.
- **There is no implied guarantee of a final product.** Aion FX provides the ingredients and the recipe, but you are responsible for putting everything together to make it work. We've tried to make the process as clear and accessible as possible, but it must be expressly stated that purchasing the kit is not a guarantee that you will end up with a working pedal.

It's recommended to read through all of the instructions before you start, particularly if you've never built a pedal before. If you familiarize yourself with the entire process ahead of time and you know what the goal looks like, each step will make more sense.

Now, on to the fun stuff!

PACKING LIST (VARIATIONS)

This is a list of all the parts that are included with the kit, grouped by value and variant. The next page lists all the parts that are common between all versions. For a list of all the parts based on their PCB part numbers, please see pages 30-31.

If you find that any parts are missing or damaged, please fill out the Missing Parts form.

Film Capacitors

TRIANGLE

NAME	QTY
3n9	2
10n (0.01)	2
100n (0.1)	8

VIOLET

NAME	QTY
3n9	2
10n (0.01)	2
100n (0.1)	8

GILMOUR

NAME	QTY
3n9	2
12n (0.012)	2
100n (0.1)	8

CIVIL WAR

NAME	QTY
3n9	2
10n	2
47n	2
100n	6

Resistors

TRIANGLE

NAME	QTY
47R	1
820R	1
2k7	1
8k2	2
100k	4
100R	3
10k	2
12k	1
15k	2
33k	3
390k	1
470k	3
2M2	1

VIOLET

NAME	QTY
47R	1
100R	3
560R	1
2k7	1
8k2	2
10k	1
12k	4
33k	3
100k	4
470k	4
2M2	1

GILMOUR

NAME	QTY
47R	1
100R	3
560R	1
2k7	1
10k	7
33k	3
100k	4
470k	4
2M2	1

CIVIL WAR

NAME	QTY
47R	1
390R	3
1k	1
2k7	1
10k	4
12k	3
20k	1
22k	1
39k	1
100k	4
470k	4
2M2	1

PACKING LIST (ALL VERSIONS)

Electrolytic Capacitors

NAME	QTY
100uF	1

MLCC Capacitors

NAME	QTY
470pF (marked "471")	3
100n (marked "104")	1

Potentiometers

NAME	QTY
100kA	1
100kB	2
Dust cover	3
Knob	3
Mounting nut, potentiometer, 0.44"	3
Lock washer, potentiometer, 0.5"	3
Outer washer, potentiometer, 0.475"	3

Other

NAME	QTY
LED bezel	1
LED, blue	1
9V battery snap	1
DC jack	1
Input/output jack	2
Mounting nut, jack, 0.54"	4
Outer washer, jack, 0.6"	2
Lock washer, jack, 0.5" (thin)	2
Enclosure	1
Enclosure screws	4
PCB, main circuit	1
PCB, footswitch	1
PCB, input/output/DC	1

Transistors

NAME	QTY
2N5088	4

Diodes

NAME	QTY
1N5817	1
1N914	4

Switches

NAME	QTY
Toggle switch, DPDT on-on-on	1
Mounting nut, toggle switch, 0.36"	1
Lock washer, toggle switch, 0.4"	1
Dress nut, toggle switch, 0.375"	1
Stomp switch, 3PDT	1
Mounting nut, stomp switch, 0.6"	2
Lock washer, stomp switch, 0.6"	1
Dress nut, stomp switch, 0.77"	1

Wiring

NAME	QTY
3-strand wire assembly, 70mm	2
4-strand wire assembly, 108mm	1
3-pin wire assembly header	2
4-pin wire assembly header	1

TOOLS NEEDED

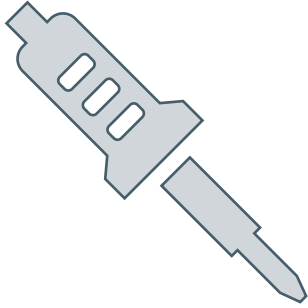

SOLDERING IRON

Temperature-adjustable is recommended. The optimum soldering temperature is 700-725° F (371-385° C) for leaded solder, or 750° F (400° C) for lead-free.

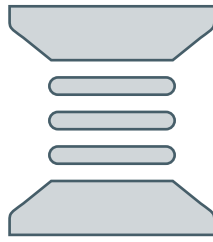

SOLDER

Preferably 63/37 or 60/40 leaded solder. Lead-free is more difficult to use, so if that's the only type you can get, it's best to watch tutorials that are specific to lead-free solder.

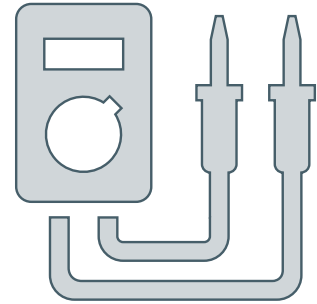

DIGITAL MULTIMETER (DMM)

Most cheap ones in the \$10-30 range are fine for what we're doing. Make sure it has audible continuity testing (i.e. it beeps at the lowest resistance) and transistor hFE measurement.

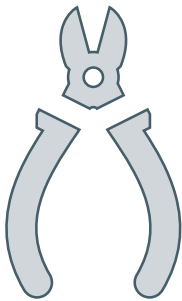

WIRE SNIPPERS

Also called nippers or wire cutters. The Hakko CHP-170 is the best you can get for less than \$10.

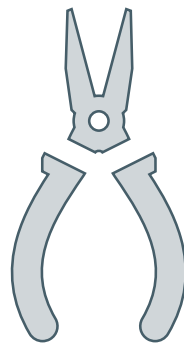

FLAT-NOSE PLIERS

Many general-purpose uses, but particularly tightening the nuts of pots, switches and jacks. Quicker than changing out sockets on a ratchet.

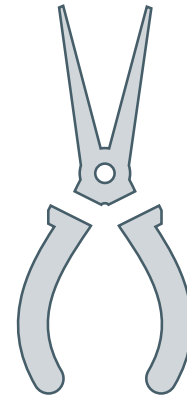

NEEDLE-NOSE PLIERS

These are used for bending leads on components and other general uses. Use the smaller type with a tip that's approximately 0.05" (1.25mm) wide.

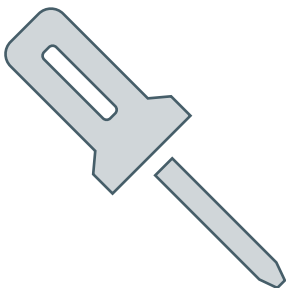

SCREWDRIVER (PHILLIPS)

Used for the enclosure screws. Get a powered driver if you'll be building a lot of pedals!

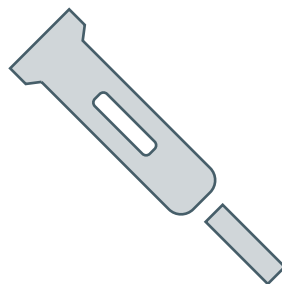

FLAT SCREWDRIVER (SMALL)

This is used for tightening the set screws on the knobs. The tip should be no more than 0.1" (2.5mm) wide.

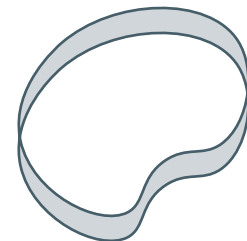

RUBBER BAND

Yes, a plain old rubber band. This is used to tighten the dress nut to avoid scratching or denting it (which can happen with metal tools).

COMPONENT IDENTIFICATION

If you've never built a pedal before, you'll need to know what all the components are. These are shown actual size. (Not all of these types of components may be part of this kit.)

RESISTOR

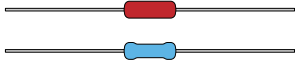

TRIMMER POTENTIOMETER

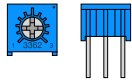

LED

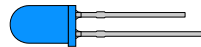

SILICON DIODE



GERMANIUM DIODE

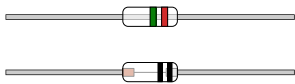

These are very fragile, so be careful when handling them.

RECTIFIER DIODE



SCHOTTKY DIODE



Some Schottky diodes also look like this.

ZENER DIODE



FILM CAPACITOR

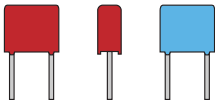

Not polarized. Color may vary by brand and type.

ELECTROLYTIC CAPACITOR



Polarized. The negative side is marked.

MLCC

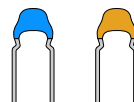

Not polarized. MLCC stands for "multi-layer ceramic capacitor."

TANTALUM CAPACITOR



Polarized. The positive side is marked.

OP-AMP / IC



Charge pumps and delay chips also look like this. They may have more than 8 legs.

IC SOCKET

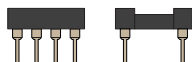

TRANSISTOR, JFET, MOSFET

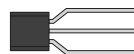

Some voltage regulators also look like this.

SNAP-APART SOCKET

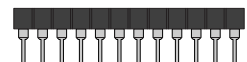

It's recommended to use a razor blade to separate these cleanly.

WIRE ASSEMBLY



WIRE ASSEMBLY HEADER

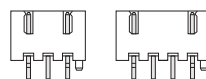

DC JACK

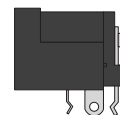





LED BEZEL



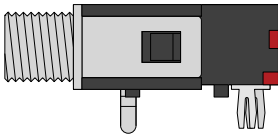
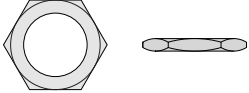
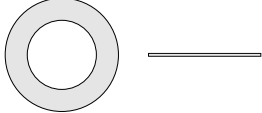
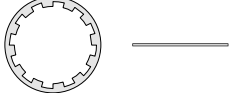

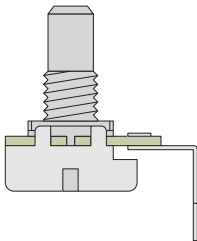
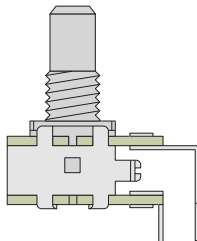
HARDWARE IDENTIFICATION

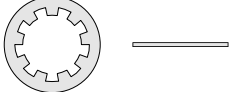
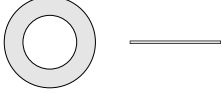
The hardware comes unassembled, so you'll need to sort & identify each of the pieces. The diagrams below are actual size, so you can set them against the printed page to identify them if needed.

<p>I/O JACK</p> 	<p>MOUNTING NUT</p>  <p>DIAMETER: 0.54" / 13.7mm</p>	<p>OUTER WASHER</p>  <p>DIAMETER: 0.6" / 15.2mm</p>	<p>LOCK WASHER</p>  <p>DIAMETER: 0.5" / 12.7mm</p>
----------------------------------------------------------------------------------------------------------	----------------------------------------------------------------------------------------------------------------------------------------------	----------------------------------------------------------------------------------------------------------------------------------------------	----------------------------------------------------------------------------------------------------------------------------------------------

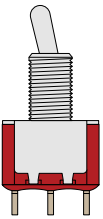
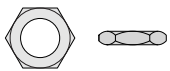
<p>POTENTIOMETER (SINGLE)</p> 	<p>POTENTIOMETER (DUAL)</p> 	<p>MOUNTING NUT</p>  <p>DIAMETER: 0.44" / 11.2mm</p>	<p>LOCK WASHER</p>  <p>DIAMETER: 0.5" / 12.7mm</p>
		<p>OUTER WASHER</p>  <p>DIAMETER: 0.475" / 12mm</p>	<p>KNOB</p> 

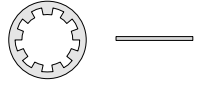
<p>TOGGLE SWITCH</p> 	<p>MOUNTING NUT</p>  <p>DIAMETER: 0.36" / 9.1mm</p>	<p>DRESS NUT</p>  <p>DIAMETER: 0.375" / 9.5mm</p>	<p>LOCK WASHER</p>  <p>DIAMETER: 0.4" / 10.1mm</p>
-----------------------------------------------------------------------------------------------------------------	-----------------------------------------------------------------------------------------------------------------------------------------------	----------------------------------------------------------------------------------------------------------------------------------------------	------------------------------------------------------------------------------------------------------------------------------------------------

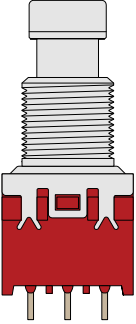
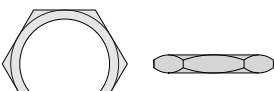
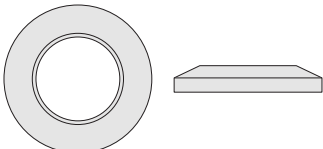
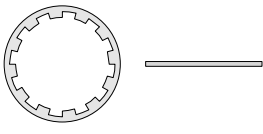
<p>FOOTSWITCH</p> 	<p>MOUNTING NUT</p>  <p>DIAMETER: 0.6" / 15.2mm</p>	<p>DRESS NUT</p>  <p>DIAMETER: 0.77" / 19.6mm</p>	<p>LOCK WASHER</p>  <p>DIAMETER: 0.6" / 15.2mm</p>
--------------------------------------------------------------------------------------------------------------	-----------------------------------------------------------------------------------------------------------------------------------------------	----------------------------------------------------------------------------------------------------------------------------------------------	------------------------------------------------------------------------------------------------------------------------------------------------

PCB ASSEMBLY OVERVIEW

Now it's time to start building!

Before you begin, separate the PCBs into individual boards and break off the tabs from each using needle-nose or flat-head pliers. You should be left with the three PCBs shown to the right.

The general principle for PCB population is that you want to work in layers from shortest components (i.e. lowest-profile) to tallest so that when the PCB is upside-down, everything is making contact with the work surface and is held in place.

Generally speaking, you should populate the components in this order:

1. Resistors
2. Diodes
3. IC sockets
4. MLCC capacitors
5. Film capacitors
6. Transistors
7. Electrolytic capacitors

Not all of these component types are included in each kit, so skip them if they aren't applicable. Some types of film capacitors are taller than electrolytics, so those can be done last.

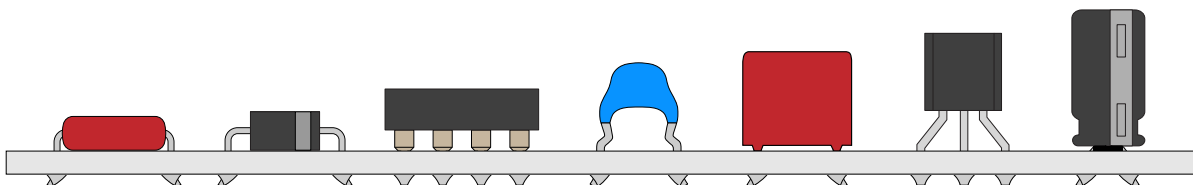
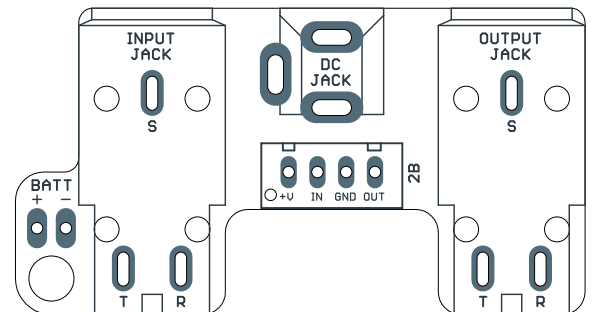
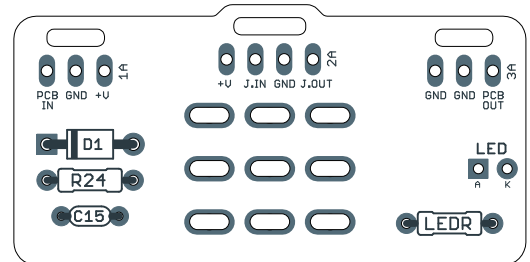
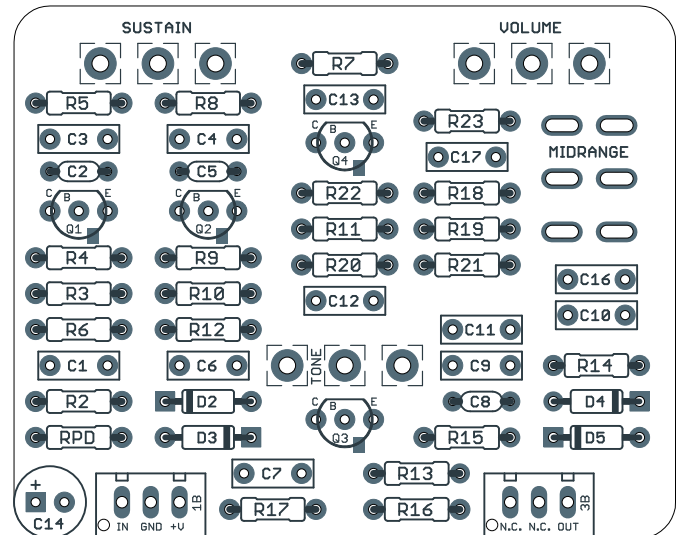

KIT VARIANTS

The Big Muff circuit has been in production for over 50 years, and it has undergone several significant changes during that time. Several versions have become classics in their own rights, and there is no “best” or definitive version of the circuit.

Accordingly, this kit is split into variants that cover the four most notable Big Muff versions, which have traditionally been given nicknames according to their cosmetic appearance.

Triangle (1971)

This was the first mass-produced version of the Big Muff, nicknamed the “Triangle” because the three controls were arranged in a triangular shape, as opposed to the later designs where they were all in a line. Since it was the first version, it’s usually the benchmark by which the other versions are described, meaning it has a balanced gain & EQ and a gentle midrange scoop.

Violet Ram’s Head (1973)

Compared to the Triangle, it has a more pronounced mid-scoop and exceptional sustain. It has a distinctive ram’s head graphic in the lower-right corner, and in the most famous version, the enclosure is screenprinted in all violet ink.

Gilmour (1974)

A red and black Ram’s Head that David Gilmour has used since the mid-1970s. It has several small differences from the Violet Ram’s Head, but most notably a slight cut to the low mids along with reduced gain in the two clipping stages.

Civil War (1991)

Produced throughout the 1990s in post-Soviet Russia, favored by bassists due to the increased low-end emphasis and slightly reduced gain. Also called the Green Russian, which was the same circuit in a different enclosure.

The kit variants differ only in the resistors (pages XX-XX) and a small number of non-polarized capacitors (page XX). The diodes, transistors, potentiometers, switches, and hardware are the same across all versions, and the rest of the build instructions are the same.

RESISTORS OVERVIEW

Using the parts list on the following pages, populate the resistors by pushing them through the holes and bending the leads outward at an angle to hold them in place. Resistors are not polarized, so they will work in any direction.

Turn the board upside-down to keep the components held in place while you solder. This technique is used for the diodes, capacitors and transistors as well.

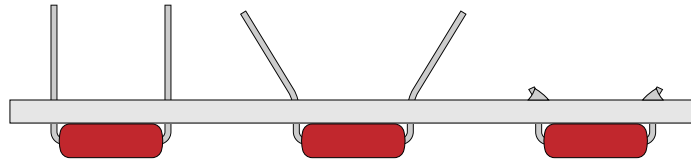

Note that the resistors have thick leads and should be bent very close to the body in order to sit flat against the board. This is not critical, so if they sit above the board slightly or at an angle, it's not going to cause any issues.

You'll want to stop periodically to flip the board and solder everything, then cut the leads using the wire snippers to make room for more. Generally you don't want to do more than ~15 components at a time or the bottom of the board will get too crowded and soldering will be difficult.

If this is your first time soldering, watch tutorial videos on YouTube and make sure you get it down before you begin. Poor soldering technique is the most common cause of failure for beginners. You don't want to practice or experiment on this board!

RESISTORS (TRIANGLE)

IMPORTANT NOTE

This resistor list is for the **Triangle** version of the circuit. The component bag is colored **yellow**. The other variants are listed on separate pages: Violet Ram's Head (purple) on pg. 13, Gilmour (pink) on pg. 14, and Civil War (red) on pg. 15.

PART	VALUE
R2	33k
R3	100k
R4	470k
R5	100R
R6	15k
R7	820R
R8	8k2

PART	VALUE
R9	100k
R10	470k
R11	100R
R12	10k
R13	8k2
R14	100k
R15	470k

PART	VALUE
R16	100R
R17	15k
R18	33k
R19	33k
R20	390k
R21	100k
R22	12k

PART	VALUE
R23	2k7
R24	47R
RPD	2M2
LEDR	10k

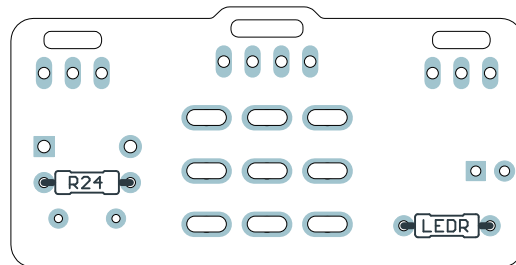
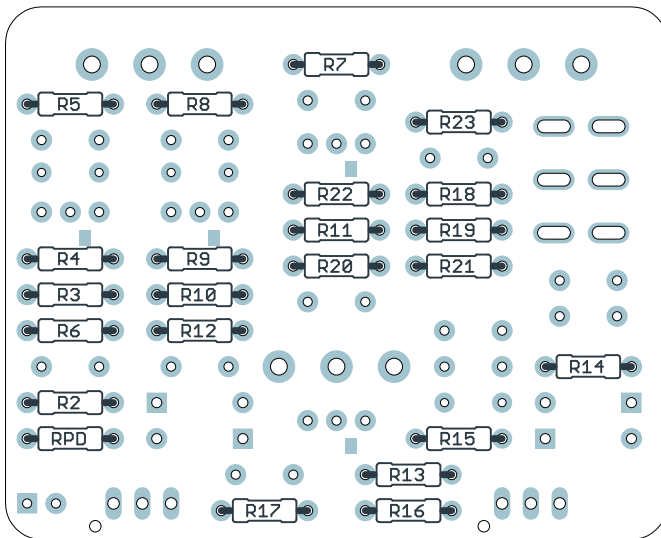

RESISTORS (VIOLET RAM'S HEAD)

IMPORTANT NOTE

This resistor list is for the **Violet Ram's Head** version of the circuit. The component bag is colored **purple**. The other variants are listed on separate pages: Triangle (yellow) on pg. 12, Gilmour (pink) on pg. 14, and Civil War (red) on pg. 15.

PART	VALUE
R2	33k
R3	100k
R4	470k
R5	100R
R6	12k
R7	560R
R8	8k2

PART	VALUE
R9	100k
R10	470k
R11	100R
R12	12k
R13	8k2
R14	100k
R15	470k

PART	VALUE
R16	100R
R17	12k
R18	33k
R19	33k
R20	470k
R21	100k
R22	12k

PART	VALUE
R23	2k7
R24	47R
RPD	2M2
LEDR	10k

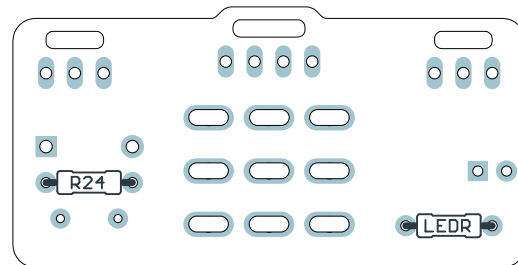
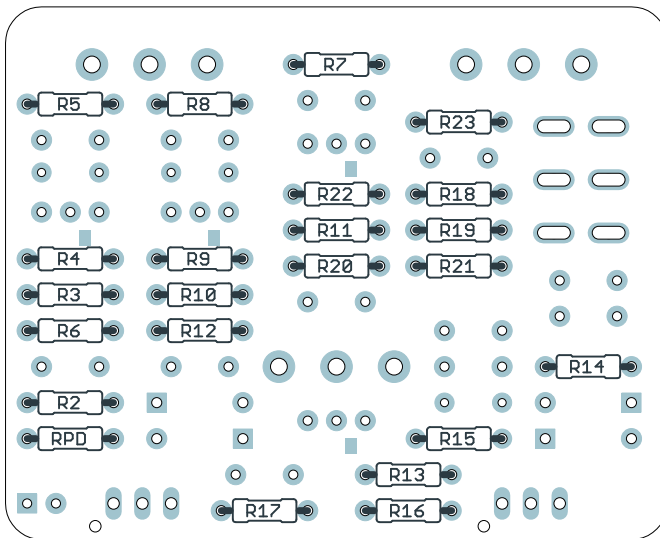

RESISTORS (GILMOUR)

IMPORTANT NOTE

This resistor list is for the **Gilmour** version of the circuit. The component bag is marked **pink**. The other variants are listed on separate pages: Triangle (yellow) on pg. 12, Violet Ram's Head (purple) on pg. 13, and Civil War (red) on pg. 15.

PART	VALUE
R2	33k
R3	100k
R4	470k
R5	100R
R6	10k
R7	560R
R8	10k

PART	VALUE
R9	100k
R10	470k
R11	100R
R12	10k
R13	10k
R14	100k
R15	470k

PART	VALUE
R16	100R
R17	10k
R18	33k
R19	33k
R20	470k
R21	100k
R22	10k

PART	VALUE
R23	2k7
R24	47R
RPD	2M2
LEDR	10k

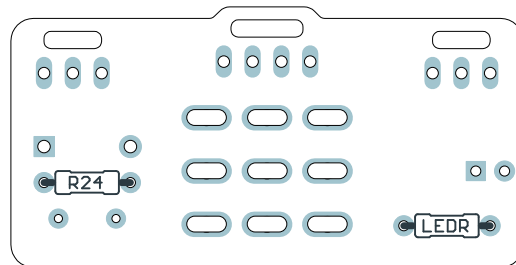
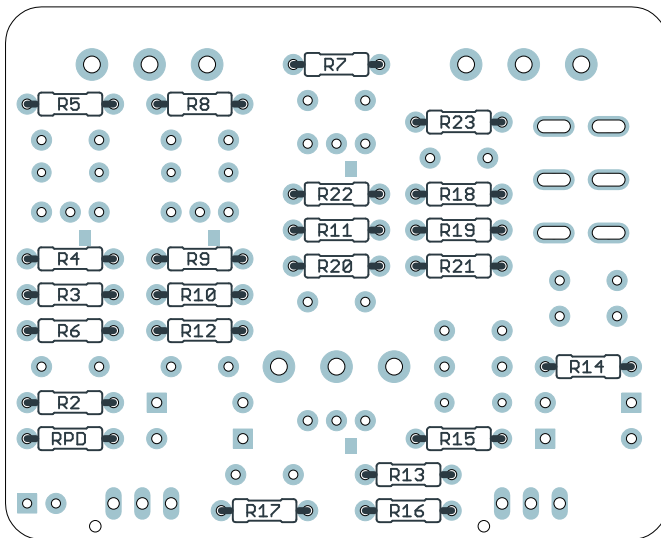

RESISTORS (CIVIL WAR)

IMPORTANT NOTE

This resistor list is for the **Civil War** version of the circuit. The component bag is marked **green**. The other variants are listed on separate pages: Triangle (yellow) on pg. 12, Violet Ram's Head (purple) on pg. 13, and Gilmour (pink) on pg. 14.

PART	VALUE
R2	39k
R3	100k
R4	470k
R5	390R
R6	12k
R7	1k
R8	10k

PART	VALUE
R9	100k
R10	470k
R11	390R
R12	12k
R13	10k
R14	100k
R15	470k

PART	VALUE
R16	390R
R17	12k
R18	22k
R19	20k
R20	470k
R21	100k
R22	10k

PART	VALUE
R23	2k7
R24	47R
RPD	2M2
LEDR	10k

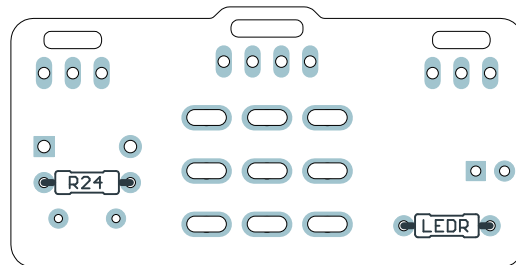
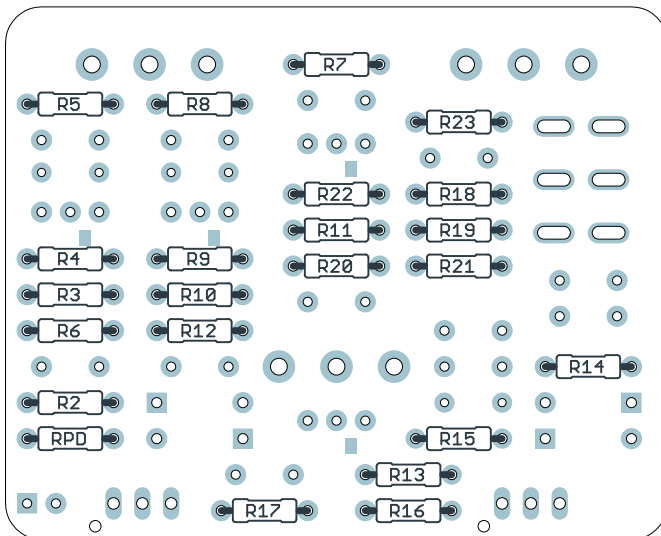

DIODES

PART	VALUE
D1	1N5817
D2	1N914
D3	1N914
D4	1N914
D5	1N914

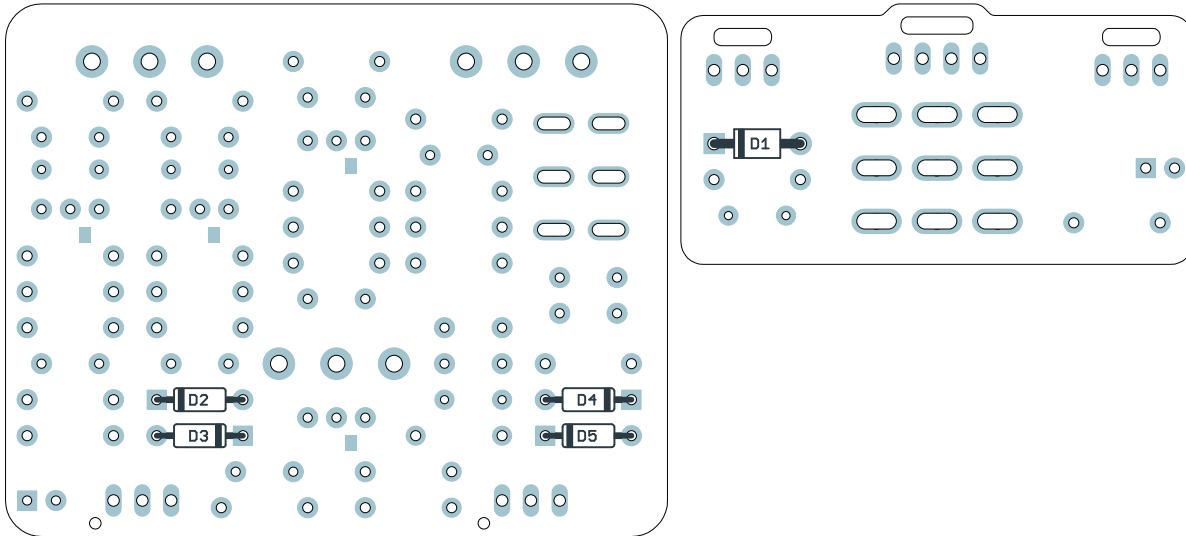

Next, you'll populate the diodes. Diodes are polarized, so make sure to identify the polarity band (which indicates the "cathode", or negative side) and match the band to the footprint on the PCB.

TRANSISTORS

PART	VALUE
Q1	2N5088
Q2	2N5088
Q3	2N5088
Q4	2N5088

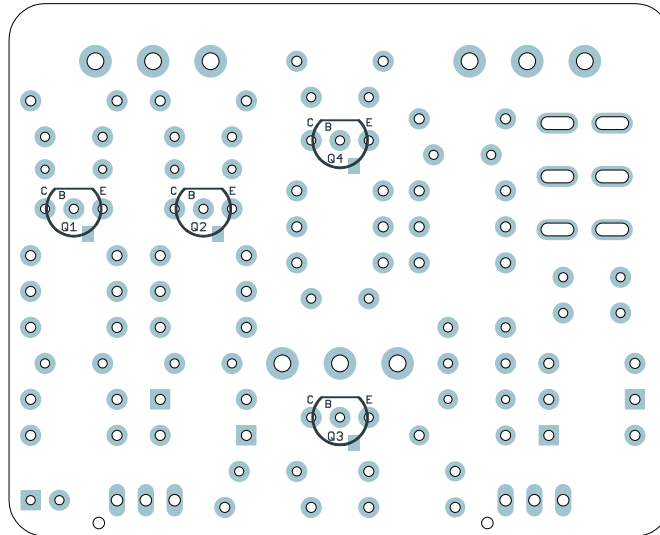

Now we'll do the transistors. If the legs are not already bent into 0.1" spacing, use your needle-nose pliers to bend the outer two legs as shown.

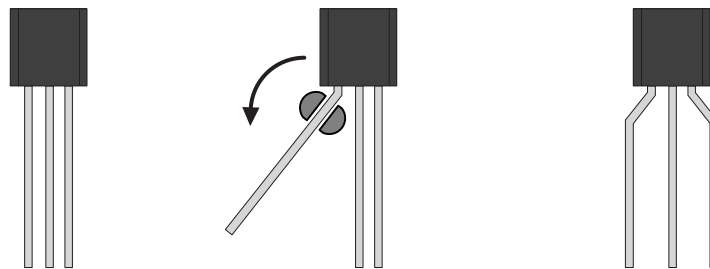

Since the transistors are used in a gain-limited application, they don't need to be selected for any particular characteristics, and sockets are not necessary. You can just solder them directly to the board.

Bend the outer leads to hold it in place on the board. Then, solder them and clip the leads.

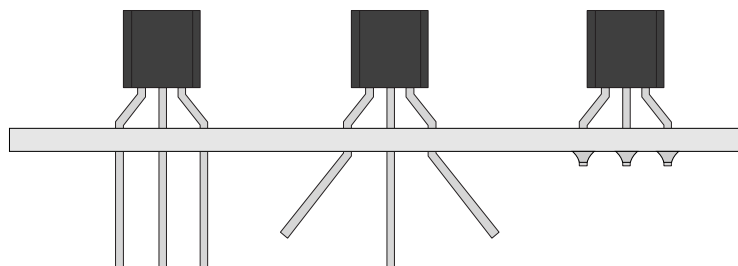

Note that the PCB has an extra pad to the left of each transistor, marked "E". This should be ignored and left empty. These are used for transistors with alternate pin configurations.

CAPACITOR IDENTIFICATION

Before the next step, we need to provide some information on how to identify the value of a capacitor. All of the supplied capacitors have the value printed on them, but there are multiple ways to format this value and no consistent standard between manufacturers. We use several different brands in our kits depending on availability, so it's not possible to give a reliable indicator of what the marking will be.

In audio circuits, most signal capacitors fall between 1 nanofarad (nF) and 1 microfarad (μF). Anything below that range is always given in picofarads (pF), and anything above is always the μF value. Within that range, the DIY audio community usually uses the nF value, often abbreviated to just "n".

In practice, though, a 100n capacitor may be marked in any of these ways:

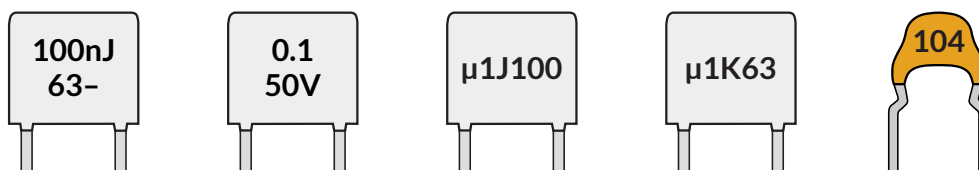

All of the text has a purpose, but for this kit, you only need to know the capacitance value and the rest can be ignored. Here are a few basic rules that will help with this.

- **1 μF = 1,000nF.** If it doesn't specify μF or nF, then always assume μF .
 $0.1 = 0.1\mu\text{F} = 100\text{n}$
 $0.022 = 0.022\mu\text{F} = 22\text{n}$
- **The "n" or " μ " designator may be used in place of a decimal point.** This is from the days of paper schematics and low-quality copies when a stray speck of ink could cause significant mistakes.
 $3\text{n}3 = 3.3\text{nF}$
 $\mu 47 = 0.47 = 470\text{n}$
- **"J" or "K" and everything afterward can be ignored.** This represents the tolerance (J = 5%; K = 10%) and the maximum voltage. We ensure that all of the capacitors in this kit meet the minimum requirements for the circuit, so you will not need to decode either of these ratings.
 $\mu 1\text{J}100$ or $\mu 1\text{K}63 = \mu 1 = 0.1 = 100\text{n}$
 $1\text{n}0\text{J} = 1\text{n}0 = 1.0\text{n} = 1\text{n}$
- **For film capacitors, the value may be printed on either the top or the front of the case.** Check the top first, and if it's blank, look at the front. If the value is printed on the top, then the front will have extraneous information such as the maximum voltage, series name, and production date code.
- **Ceramic capacitors (MLCCs) use a separate 3-digit code format.** Since these are often difficult to read without magnification, we don't rely on this code to identify MLCC capacitors.
 - Nearly all kits come with a single yellow 100n MLCC that is used for power filtering.
 - All other MLCCs are taped to cardboard strips.
 - If there is more than one other value in the kit, the values will be written on the cardboard to differentiate them. This value will be in the same format as the parts list, e.g. "100pF".

CAPACITORS (NON-POLARIZED)

PART	VALUE	PART	VALUE	PART	VALUE	PART	VALUE
C1	100n (0.1)	C6	100n or 47n	C11	10n or 12n	C17	3n9
C2	470pF MLCC	C7	100n (0.1)	C12	100n (0.1)		
C3	100n (0.1)	C8	470pF MLCC	C13	100n (0.1)		
C4	100n (0.1)	C9	100n or 47n	C15	100n MLCC		
C5	470pF MLCC	C10	3n9	C16	10n or 12n		

IMPORTANT NOTE

C6 and C9 are **47n** (0.047uF) for the Civil War version and **100n** (0.1) for the others.

C11 and C16 are **12n** (0.012) for the Gilmour version and **10n** (0.01) for the others.

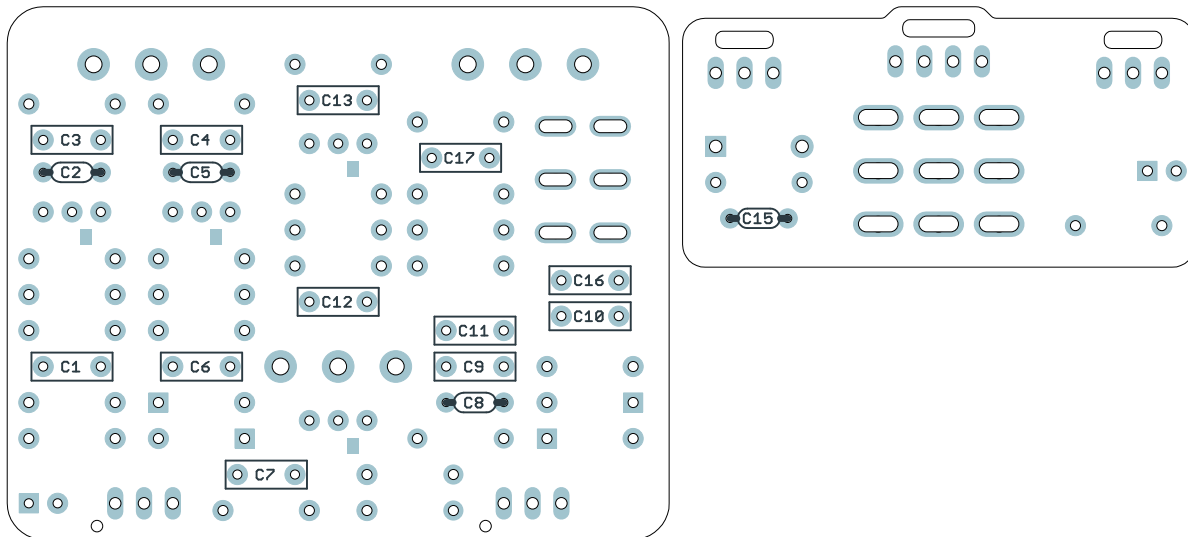

After the transistors come the box film and MLCC capacitors. These are all several different heights, but there aren't as many, so just do them all at once. Bend the leads at an angle to hold them in place.

MLCCs and box capacitors are not polarized and will work in any orientation. To keep things neat, though, it's recommended to install them facing the same direction.

Note: For the box film capacitors, the value may be printed on either the top or the side. See previous page for capacitor identification.

The 470pF MLCC capacitors (C2, C5, C8) are blue and will come taped to a cardboard strip in a set of 3. The 100n MLCC capacitor (C15) is yellow and will be loose. For these, the value is difficult to read, so it's easier to identify them by color.

WIRE HEADERS

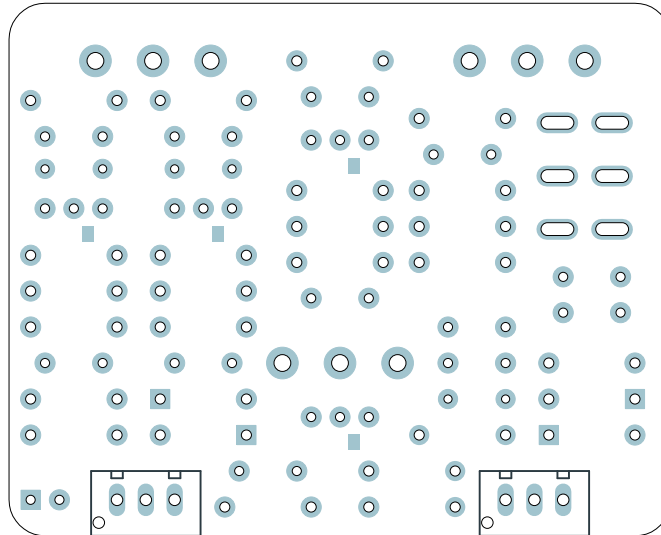

Install the two 3-pin headers (wire connectors) as shown above. These have a polarity pin, so as long as they are pressed all the way down, there's only one possible way to install them. They do fit pretty tightly in the holes, so press firmly.

There's also a 4-pin header on the I/O board that we will do in a later step.

CAPACITORS (POLARIZED)

PART	VALUE
C14	100uF

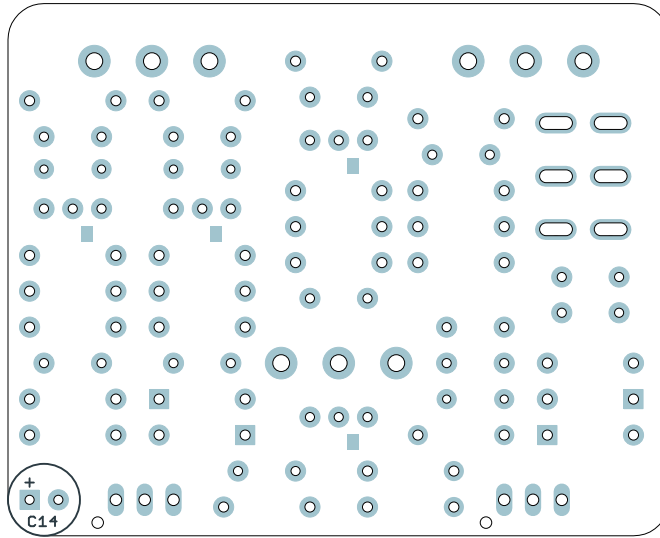

Populate the electrolytic capacitor. This is the tallest component so we save it for last. Electrolytic capacitors are polarized (i.e. they will only work in one direction), so note the vertical mark that indicates the negative side. The longer leg is positive and fits in the square pad.

This is the last of the on-board components.

FOOTSWITCH PCB

PARTS

3-strand wire assembly (2)

4-strand wire assembly

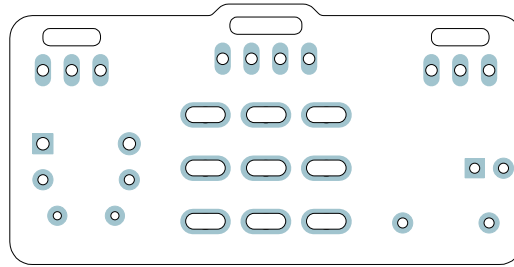

Next, it's time to finish up the footswitch board. You should have done the resistors, diode and capacitor in a previous step, but if not, go back and do those.

There will be one longer assembly with 4 wires and two shorter ones with 3 wires. The longer one goes in the middle and the shorter ones go on the left and right sides. The wire assemblies should then be soldered to the footswitch board as shown.

STEP 1

First, thread the wire through the strain-relief slots, with the blue side facing outward and the PCB's previously-installed components facing up.

For now, pull it through as far as it can go.

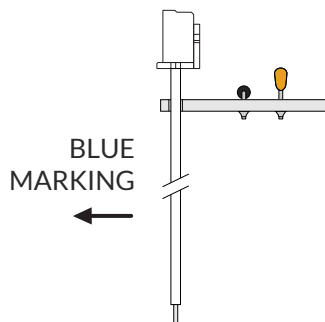

STEP 2

Next, bend the wires back upward and fit the ends of the wires into the solder pads.

On the top side of the PCB, bend the exposed wires backward so it holds the wire in place. Pull the header back up through the slot partway.

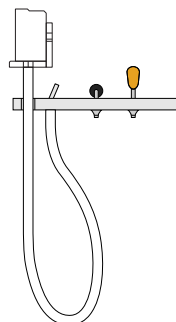

STEP 3

Then, solder the wires from the top. This is the trickiest part of the whole build. You want to solder the pads without touching the iron to the wires themselves and risking burning through the insulation. It helps to use a sharp or narrow tip on the soldering iron.

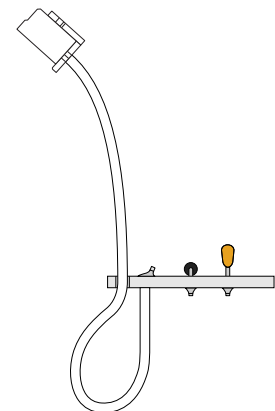

Once all three wire assemblies are soldered, set the footswitch PCB aside. We'll solder the actual footswitch and LED in a later step.

INPUT/OUTPUT PCB

PARTS

Input & output jacks

DC jack

Wire header

9V battery snap

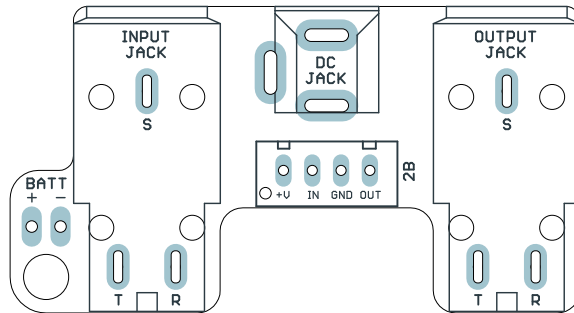

Almost done! Get the two input/output jacks, the DC jack and the wire header and snap them in place. The PCB is designed for them to fit securely, so you can do them all at once before flipping and soldering.

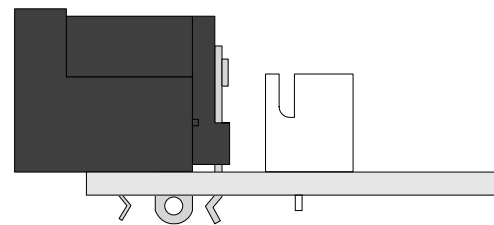
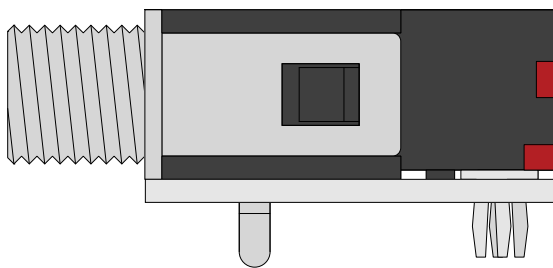

After you've soldered everything, make sure to **snip the leads on the I/O jacks as close as possible to the PCB**. There's not a lot of clearance between the bottom of this board and the top of the main PCB once everything is in place, and you don't want the pins to short against anything on accident.

Next, we'll hook up the 9V battery connector. **This is optional.** Not everyone uses batteries. But, if you do, this pedal should last a long time on a single 9V so you won't need to change it very often.

STEP 1

Thread the battery snap leads through the strain-relief hole twice so it forms a single loop.

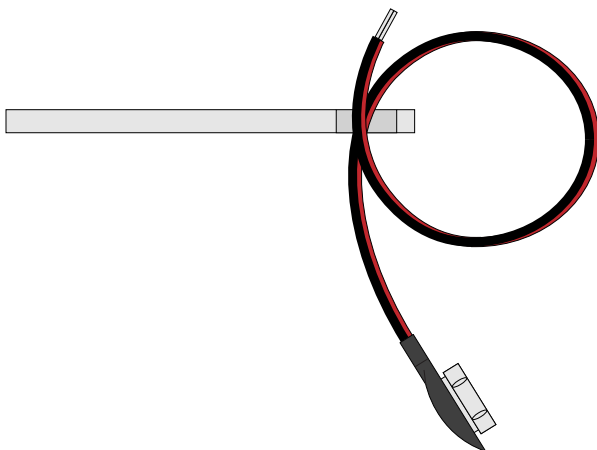

STEP 2

Bend the exposed wires back down and solder them into the pads. Red is positive (+), black is negative (-). After soldering, pull it tight.

For even more strain relief, you can thread the snap through the loop to form a knot. (not shown)

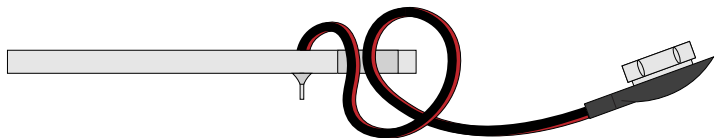

ENCLOSURE LAYOUT: PANEL MOUNTS

Attach the hardware to the enclosure as shown. (The I/O board is done in a later step.)

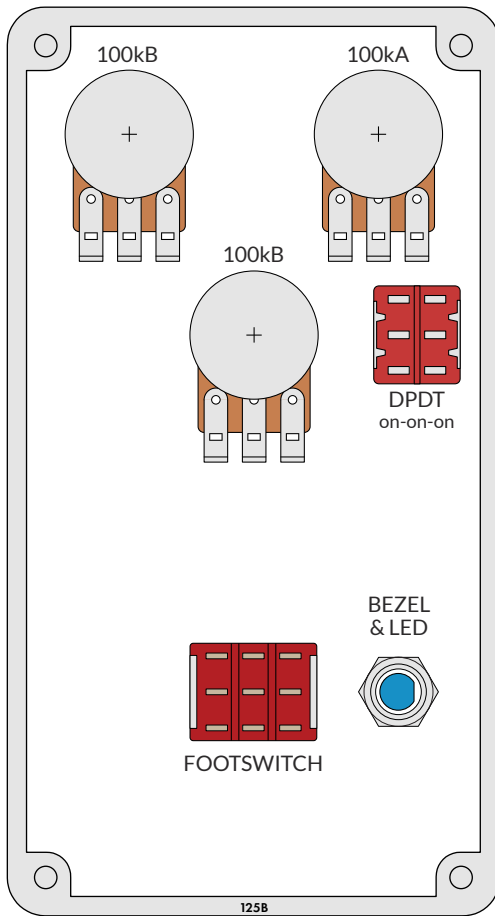

FOOTSWITCH

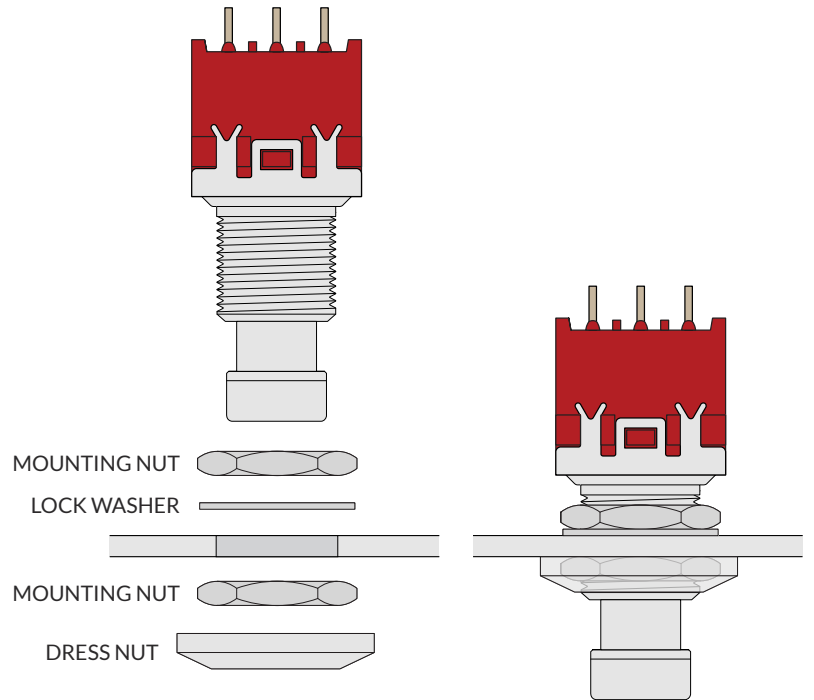

The dress nut fits over the top of the mounting nut and is for aesthetic purposes only. Wrap a rubber band around it to use as a grip when tightening. Do not use metal tools on it or you run the risk of scratching or denting it.

POTENTIOMETERS

Volume: 100kA

Tone: 100kB

Sustain: 100kC

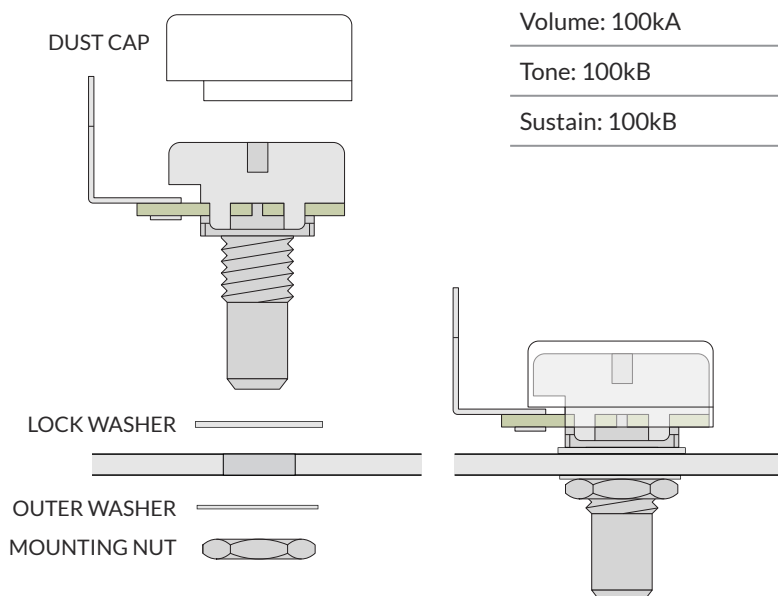

BEZEL & LED

The LED will just sit loosely inside the bezel for now.

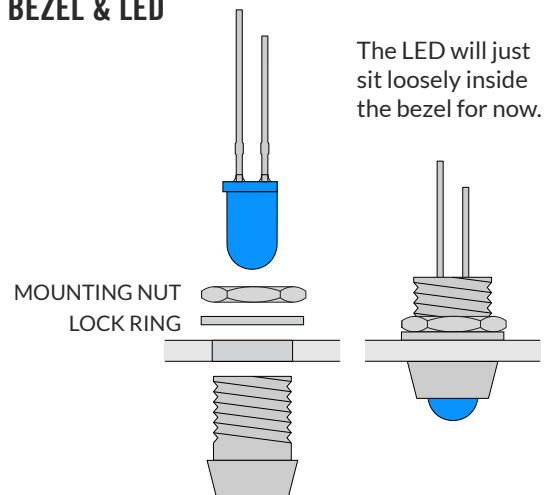

You'll need to hold the bezel in place when tightening the nut. The top of the bezel is fairly sharp, so try using a rubber band for grip instead of pressing your finger against the bottom.

ENCLOSURE LAYOUT: PANEL MOUNTS (CONT.)

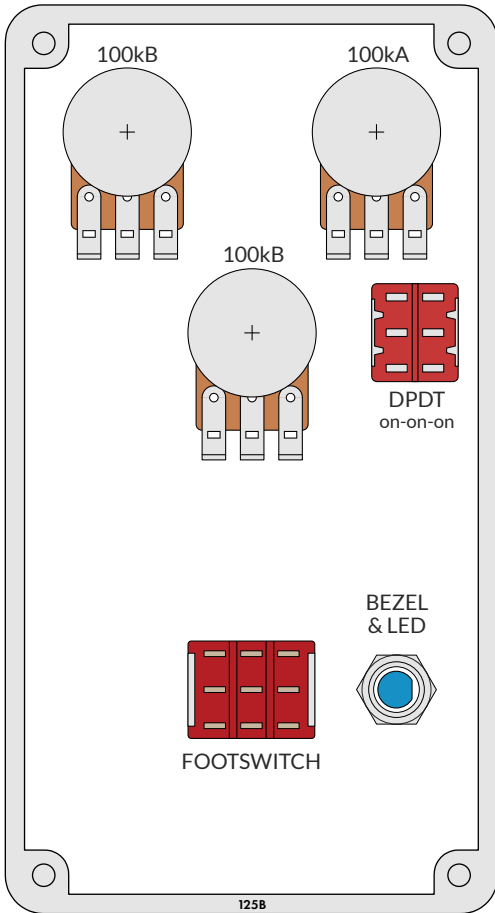

TOGGLE SWITCHES

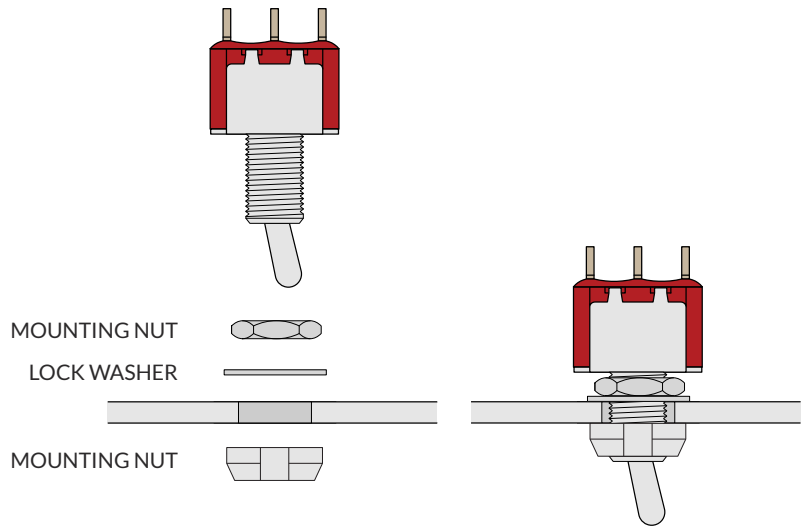

The dress nut acts as a mounting nut, unlike the footswitch dress nut. Use flat-nose pliers on the flat sides of the nut to tighten securely.

ENCLOSURE LAYOUT: MAIN & FOOTSWITCH PCBs

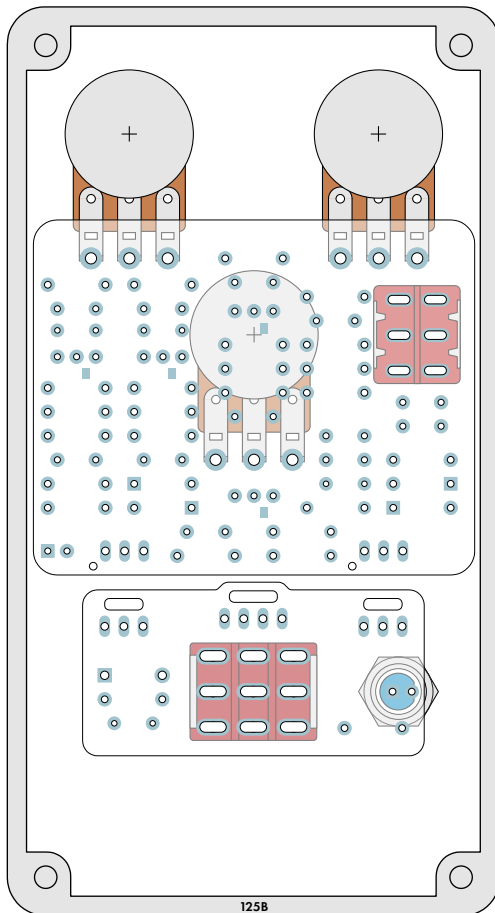

After all the components are affixed to the enclosure as shown on the previous page, place the main PCB on top of the potentiometers and toggle switches as in the diagram to the left.

You may need to adjust the position of the potentiometers and toggles slightly if they are not aligned straight.

Once all of the pins are through their holes and the PCB is laying flat, solder each of the pins from the top. Be careful not to touch any of the surrounding components with the soldering iron.

After you've finished soldering the pots, **clip the leads as close as you can to the main PCB**. This is more important with the two uppermost pots because the input/output PCB overlaps them and you need to avoid any of the components shorting. (The toggle switch lugs do not need to be clipped.)

Next, move to the footswitch board and solder the 3PDT switch.

The LED is last. Before soldering the LED, double-check to **make sure the flat side of the LED is facing to the right**, as shown in the diagram, and that the short leg is coming through the pad on the right. It won't work if it's turned the other way. Then, clip the leads of the LED.

Why solder everything inside the enclosure before testing it?

"Rock it before you box it" is conventional wisdom in pedalbuilding, and you'll often hear it recommended that builders should test the circuit before putting everything inside the enclosure. However, Aion FX projects are designed to be extremely easy to remove from the enclosure for troubleshooting, with no desoldering required—so with these kits, it's actually much easier to "box it before you rock it".

If you've read the documentation carefully and followed all the instructions, there's a good chance you will get it right the first time!

ENCLOSURE LAYOUT: INPUT/OUTPUT PCB

Affix the input/output PCB to the north-facing panel of the enclosure as shown.

Note the use of two mounting nuts on each of the jacks, one inside and one outside. The inner nut acts as a spacer to set the DC jack flush with the outside of the enclosure. The inner nuts should be threaded as far down as they can go.

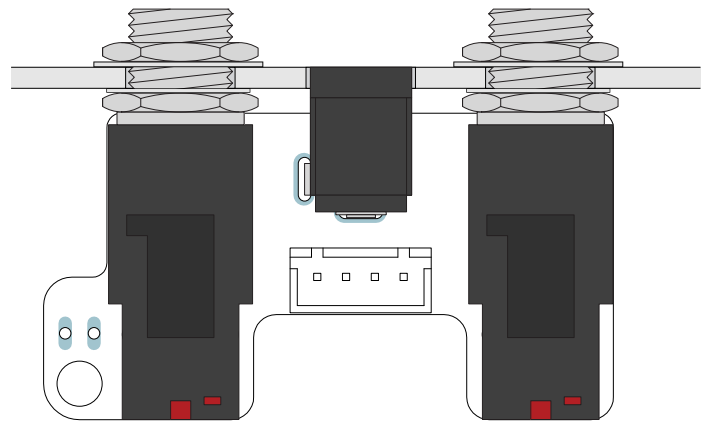
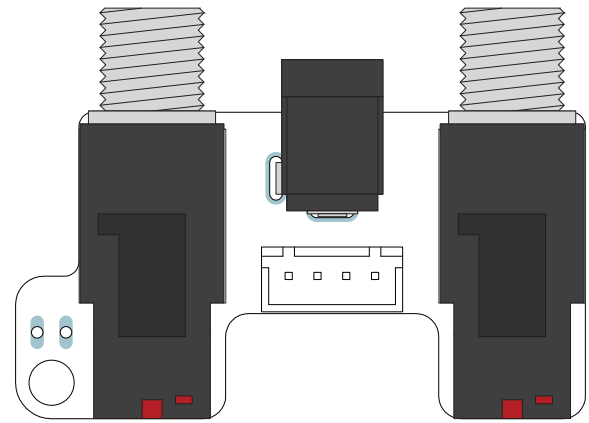
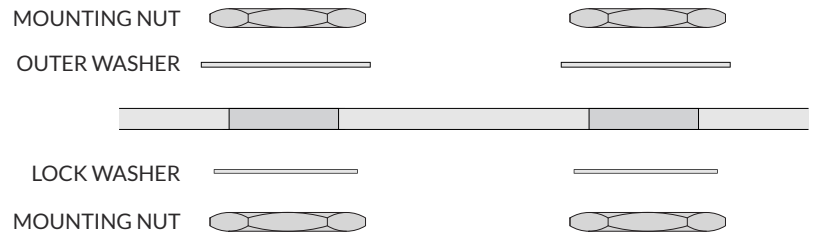
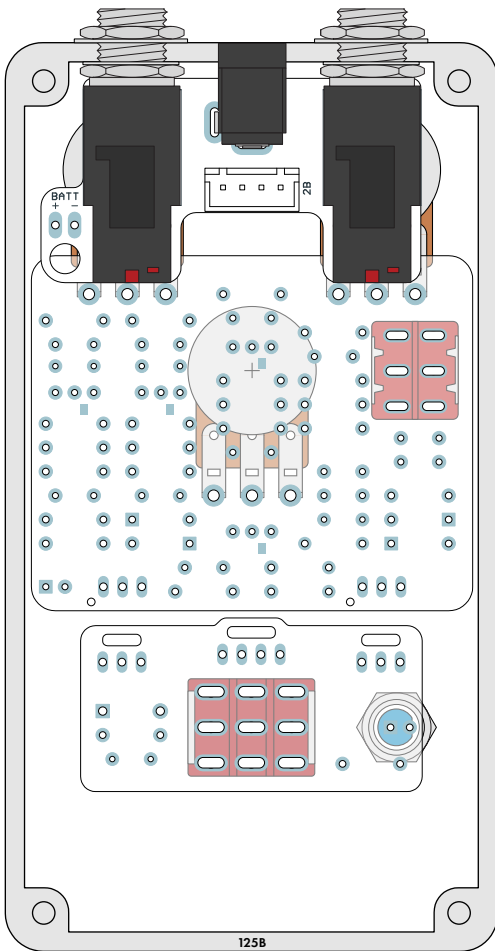

FINAL TESTING & ASSEMBLY

After everything is in place, just plug the 3 wire assemblies into their respective headers and make sure they're secure. Here is a cross-section of the inside of the completed pedal.

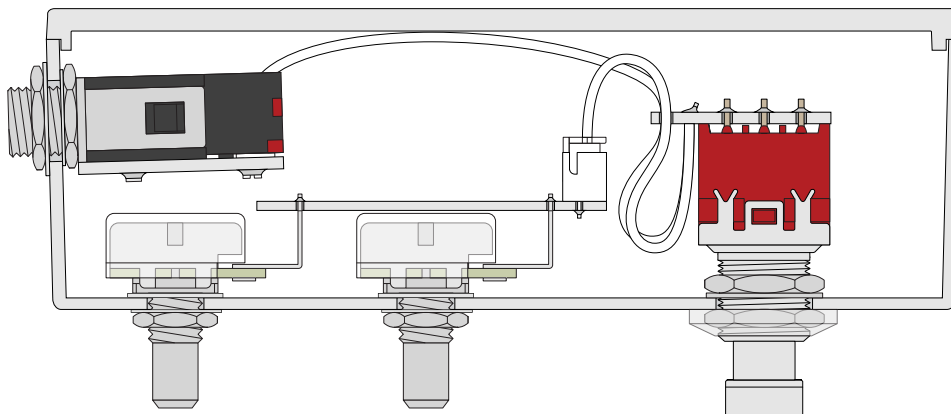

At this point, you have completed the full circuit as far as the electrons are concerned. Plug in a 9-volt supply and test it out with a guitar and an amplifier.

Test the bypass switch a few times, then start turning the knobs and see if everything sounds OK. If it works, great! If not, don't be discouraged. See page 32 for troubleshooting info.

Finishing touches

Now, just a couple of things for the final assembly. Turn the shafts all fully counter-clockwise, then put on the knob and rotate until the indicator line is aligned with the dot on the enclosure that shows the zero point. Affix the knobs to each of the potentiometer shafts as shown in the diagram below.

Using a small flat-head screwdriver (no more than 0.1" / 2.5mm in diameter), firmly tighten the set screw until it presses against the shaft of the potentiometer and holds the knob in place.

Be careful not to over-tighten or you may damage the set screw. But if it's not tight enough, the knob will be more likely to fall off or lose its alignment with the markings on the enclosure.

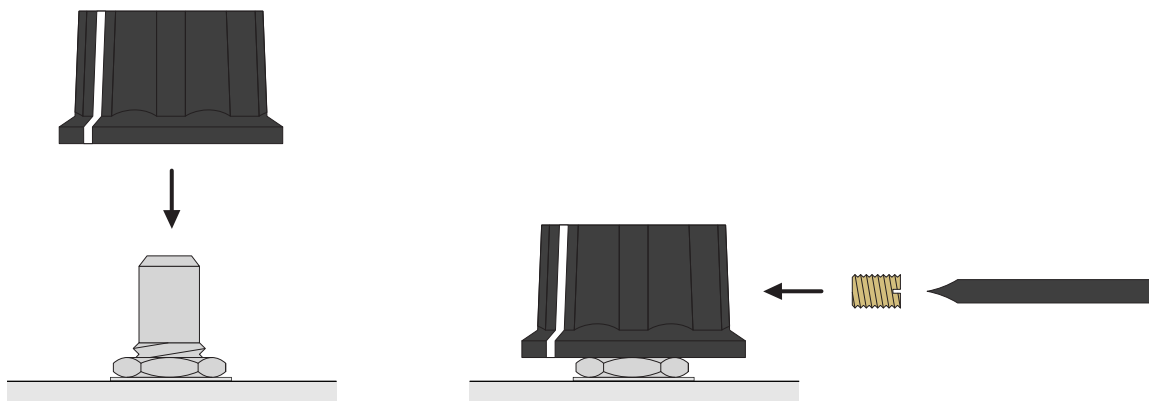

Last, just close the panel on the back using the four screws. That's it!

SCHEMATIC (VIOLET RAM'S HEAD)

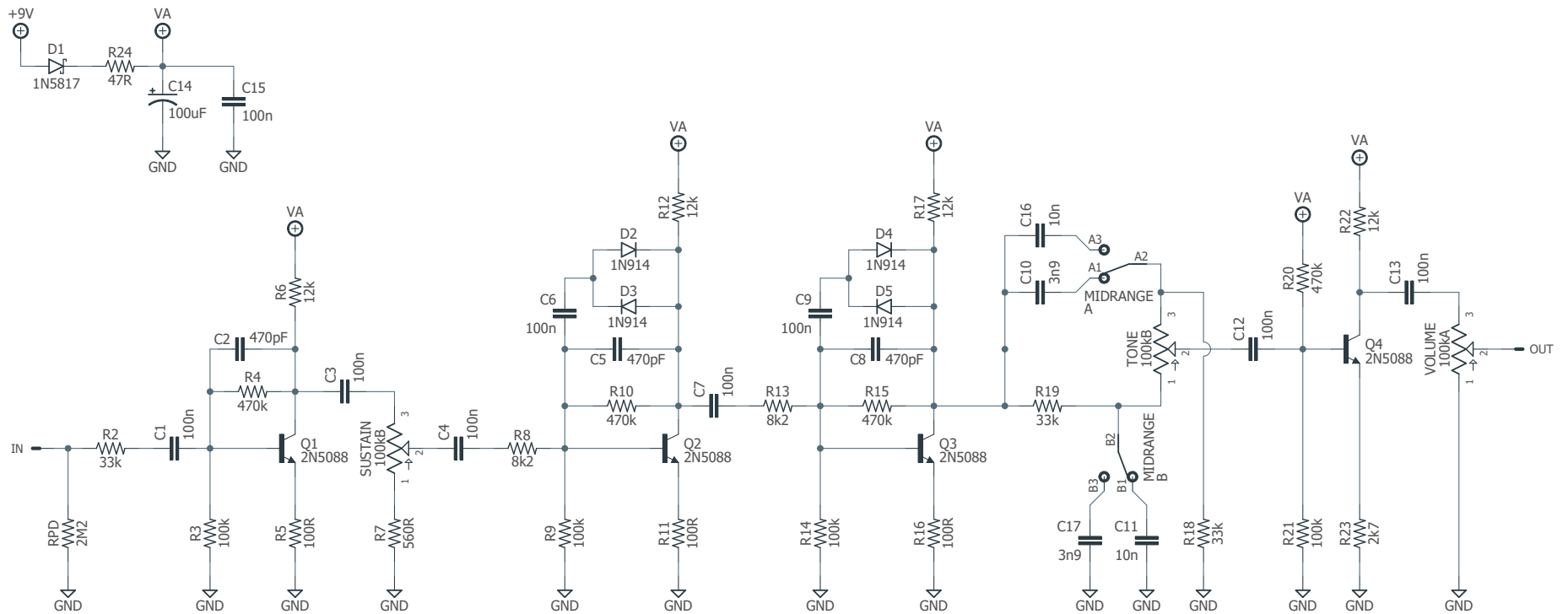

SCHEMATIC (GILMOUR)

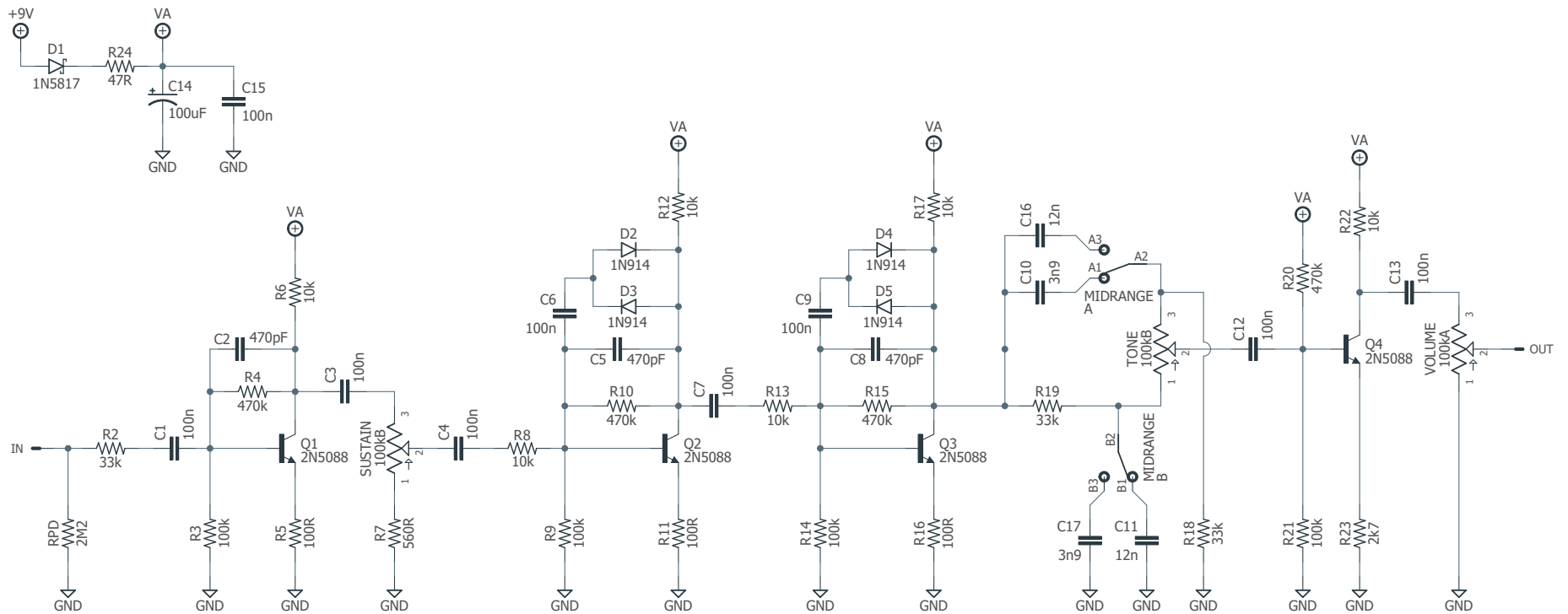

SCHEMATIC (CIVIL WAR / GREEN RUSSIAN)

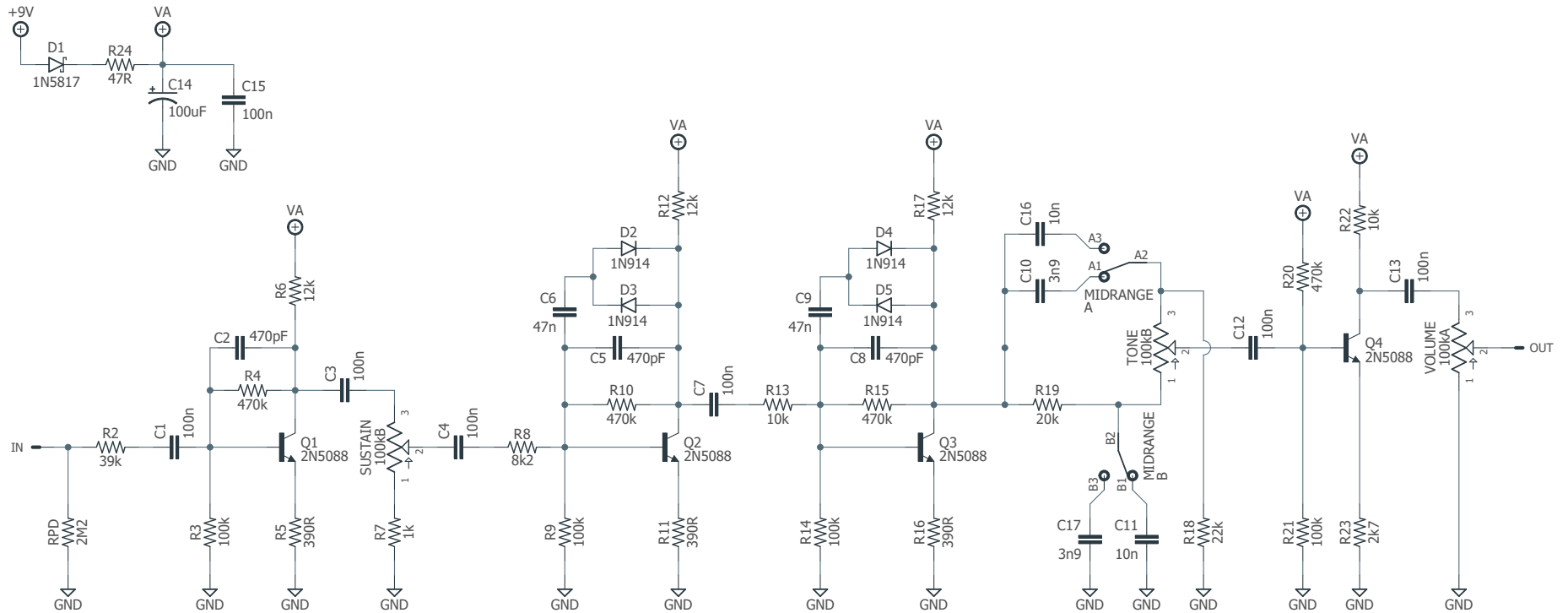

FULL PARTS LIST

Resistors (Triangle)

PART	VALUE
R2	33k
R3	100k
R4	470k
R5	100R
R6	15k
R7	820R
R8	8k2

PART	VALUE
R9	100k
R10	470k
R11	100R
R12	10k
R13	8k2
R14	100k
R15	470k

PART	VALUE
R16	100R
R17	15k
R18	33k
R19	33k
R20	390k
R21	100k
R22	12k

PART	VALUE
R23	2k7
R24	47R
RPD	2M2
LEDR	10k

Resistors (Violet Ram's Head)

PART	VALUE
R2	33k
R3	100k
R4	470k
R5	100R
R6	12k
R7	560R
R8	8k2

PART	VALUE
R9	100k
R10	470k
R11	100R
R12	12k
R13	8k2
R14	100k
R15	470k

PART	VALUE
R16	100R
R17	12k
R18	33k
R19	33k
R20	470k
R21	100k
R22	12k

PART	VALUE
R23	2k7
R24	47R
RPD	2M2
LEDR	10k

Resistors (Gilmour)

PART	VALUE
R2	33k
R3	100k
R4	470k
R5	100R
R6	10k
R7	560R
R8	10k

PART	VALUE
R9	100k
R10	470k
R11	100R
R12	10k
R13	10k
R14	100k
R15	470k

PART	VALUE
R16	100R
R17	10k
R18	33k
R19	33k
R20	470k
R21	100k
R22	10k

PART	VALUE
R23	2k7
R24	47R
RPD	2M2
LEDR	10k

FULL PARTS LIST, CONT.

Resistors (Civil War / Green Russian)

PART	VALUE
R2	39k
R3	100k
R4	470k
R5	390R
R6	12k
R7	1k
R8	10k

PART	VALUE
R9	100k
R10	470k
R11	390R
R12	12k
R13	10k
R14	100k
R15	470k

PART	VALUE
R16	390R
R17	12k
R18	22k
R19	20k
R20	470k
R21	100k
R22	10k

PART	VALUE
R23	2k7
R24	47R
RPD	2M2
LEDR	10k

Capacitors

PART	VALUE
C1	100n film (0.1)
C2	470pF MLCC
C3	100n film (0.1)
C4	100n film (0.1)
C5	470pF MLCC
C6	100n or 47n

PART	VALUE
C7	100n film (0.1)
C8	470pF MLCC
C9	100n or 47n
C10	3n9 film
C11	10n or 12n
C12	100n film (0.1)

PART	VALUE
C13	100n film (0.1)
C14	100uF electro
C15	100n MLCC
C16	10n or 12n
C17	3n9 film

C6 and C9 are 47n in the Civil War / Green Russian variant only and 100n in the others.

C11 and C16 are 12n in the Gilmour variant only and 10n in the others.

Diodes

PART	VALUE
D1	1N5817
D2	1N914
D3	1N914
D4	1N914
D5	1N914

Transistors

PART	VALUE
Q1	2N5088
Q2	2N5088
Q3	2N5088
Q4	2N5088

Potentiometers

PART	VALUE
Volume	100kA
Sustain	100kB
Tone	100kB

Switches

PART
DPDT on-on-on
3PDT stomp

TROUBLESHOOTING INFORMATION

If you finish building the kit and find that it doesn't work right, we've written a separate in-depth [Troubleshooting Guide](#) that applies to all of our kits. The main troubleshooting process is covered there. Here you will find information specific to this kit that will help with that process.

Voltages

The following voltages are taken from our prototype unit using a **9.86V** supply. Your measured voltages won't be exactly the same due to variance in power supplies and component tolerances. However, if you see anything more than +/-0.5V from the listed voltages, it's a good indicator of an issue, and the exact voltages can help narrow it down.

The transistor pins E, B and C are labeled on the PCB, so use the silkscreen as a reference when measuring the voltages.

Q1

PIN	VOLTAGE
E	0.03V
B	0.70V
C	4.68V

Q2

PIN	VOLTAGE
E	0.03V
B	0.70V
C	4.73V

Q3

PIN	VOLTAGE
E	0.03V
B	0.69V
C	4.69V

Q4

PIN	VOLTAGE
E	1.02V
B	1.70V
C	4.87V

SUPPORT

Aion FX does not offer direct support for these projects beyond the provided documentation.

Replacements and refunds cannot be offered unless it can be shown that the circuit or documentation are in error or that the included components are non-functional.

Where to get help

The three best places to ask for help are the [DIY Stompboxes forum](#), the [DIY Stompboxes Facebook group](#), and the [r/diypedals subreddit](#). These communities have more than 150,000 members between them and they are very accommodating to new builders.

When posting a troubleshooting request, always include the following:

1. A thorough description of the problem you are experiencing
2. A photo of the inside of the pedal
3. A list of all the measured voltages of each of the pins, described on the previous page

While we cannot offer direct, private support, you may send a link to your public troubleshooting thread to Aion FX using the contact form on the website. There is no guarantee that we will be able to join the discussion and help solve your problem, but this improves the chances.

It benefits the whole community if the troubleshooting process is public because then people who have the same issue in the future may come across it when searching. And if you do get help, remember to pay it forward! The best way to learn new skills is to help others. Even if you've only built one pedal, you have more experience than someone who is brand new, so you have something to offer.

RESALE TERMS

These kits may be used for commercial endeavors in any quantity unless otherwise noted. It's okay to sell individual builds locally or online, or even to offer a service to build pedals based on these kits.

No direct attribution is necessary, though a link back is always greatly appreciated. The only usage restriction is that you cannot "goop" the PCB or otherwise obscure the source. In other words: you don't have to go out of your way to advertise the fact that you use Aion FX kits, but please don't go out of your way to hide it. The guitar effects industry needs more transparency, not less!

LEGAL INFORMATION

Big Muff® and Electro-Harmonix® are registered trademarks of New Sensor Corp.

All other trademarks are property of their respective owners.

Any use of trademarks is for comparative advertising purposes only under fair use. It is not an endorsement of this product by the trademark holders.

These kits are intended to be built by the customer. Aion FX is not responsible for language that may be used by the customer in the marketing or resale of the finished product.

All content and graphics in this document are original works and are copyrighted by Aion FX and may not be used without permission.

DOCUMENT REVISIONS

2.1.1 (2026-02-XX)

Split into four variants: Triangle, Violet Ram's Head, Gilmour and Civil War. Only the resistors and capacitors are affected. The PCBs are unchanged and still labeled v2.1.

All variants are covered in this document, with certain sections (the packing list, resistor population, and schematic) being split for each of them. The rest of the instructions are shared between all variants.

2.1.0 (2025-11-28)

CX1 and CX2 renamed C16 and C17. "Mids" switch renamed "Midrange". Added capacitor identification section on page 16.

2.0.3 (2024-08-08)

Added link to troubleshooting guide on page 32.

2.0.2 (2024-04-12)

Updated LEDR (LED current-limiting resistor) to 10k to reduce brightness.

2.0.1 (2020-05-04)

Revised some diagrams for clarity.

2.0.0 (2019-12-14)

New PCB layout. Removed CX3 (no longer needs to be jumpered).

1.0.0 (2018-11-22)

Initial release.