

PROJECT NAME

# GRAVITON



BASED ON

BOSS® HM-2 Heavy Metal

BUILD DIFFICULTY

■■■■□ Intermediate

EFFECT TYPE

Metal Distortion

DOCUMENT VERSION

1.1.0 (2019-08-06)

## PROJECT SUMMARY

A unique distortion effect favored by extreme metal guitarists for its characteristic “buzzsaw” sound. It also works very well as a versatile high-gain effect in other styles of music.

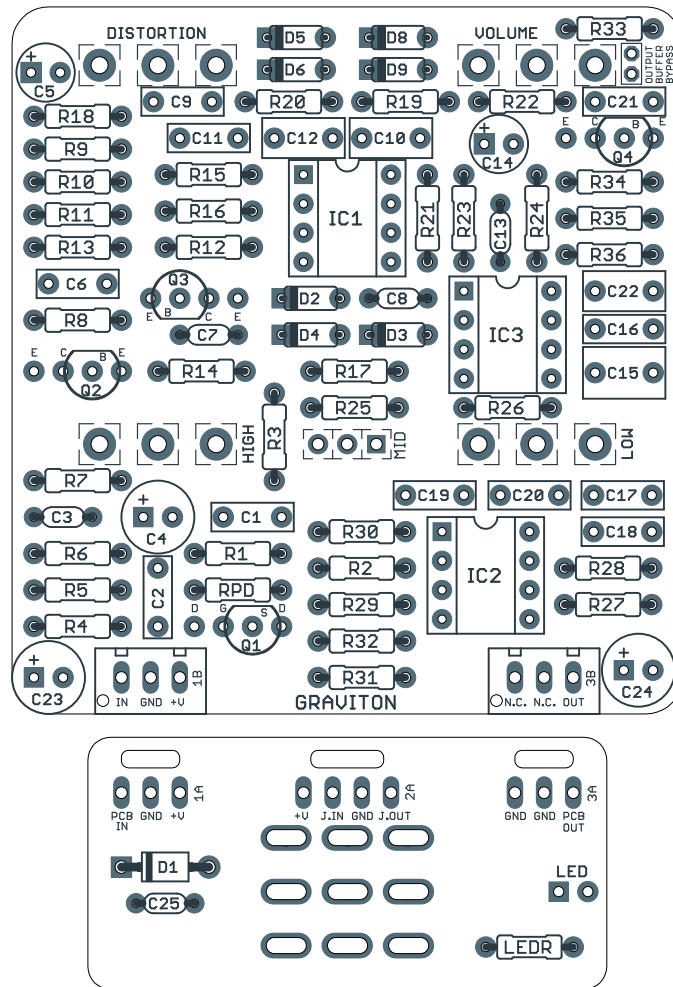

Actual size is 2.3" x 2.42" (main board) and 1.78" x 0.86" (bypass board).

# TABLE OF CONTENTS

---

1	Project Overview	8	Drill Template
2	Introduction & Usage	9	Enclosure Layout
3-5	Parts List	10	Wiring Diagram
6	Build Notes	11	Licensing
7	Schematic	11	Document Revisions

## INTRODUCTION

---

The Graviton Metal Distortion is a clone of the BOSS® HM-2 Heavy Metal, first released in 1983 and discontinued in 1991. The HM-2 was largely overlooked while it was in production, but in the mid-1990s it got the attention of a few bands in the Swedish death metal scene who developed something of a signature guitar tone by turning all the knobs to 10, often running it into a cheap solid state amp. Here is the video that first exposed this technique:

[Daniel Ekeroth Demonstrates Swedish Death Metal Guitar Sound](#)

Despite the reputation it enjoys in the extreme metal community, it is far from a one-trick pony. It's a very flexible pedal with a balanced high-gain distortion tone that works well in many styles of music.

This circuit also made an appearance as the DOD FX-56 American Metal, released in 1984. While the pedals don't really sound the same, the American Metal has almost the exact same circuit layout, just with different parts values and with the two tone knobs combined into one. You can build the American Metal with the Graviton PCB.

The HM-2 is notoriously difficult to dial in. The Distortion control seems to only have two settings, "on" and "off", with a large dead zone in the middle. The tone controls have a wide range of effect (+/-20dB at approximately 88 Hz and 1000 Hz), but these can also be a bit finicky. There are really good sounds inside this pedal, but you may need to spend some quality time with it to tease them out.

## USAGE

---

The Graviton has the following controls:

- **Distortion** simultaneously controls the signal level going into the clipping stage and the amount of gain in the clipping stage.
- **Low** and **High** form a 2-band gyrator-based EQ to control bass & treble frequencies.
- **Volume** is the output volume of the effect.

## PARTS LIST

---

This parts list is also available in a spreadsheet format which can be imported directly into Mouser for easy parts ordering. Mouser doesn't carry all the parts (most notably potentiometers) so the second tab lists all the non-Mouser parts as well as sources for each.

[View parts list spreadsheet](#) →

PART	VALUE	TYPE	NOTES
R1	10k	Metal film resistor, 1/4W	
R2	1M	Metal film resistor, 1/4W	
R3	10k	Metal film resistor, 1/4W	
R4	22k	Metal film resistor, 1/4W	
R5	100k	Metal film resistor, 1/4W	
R6	470k	Metal film resistor, 1/4W	
R7	10k	Metal film resistor, 1/4W	
R8	22R	Metal film resistor, 1/4W	
R9	150R	Metal film resistor, 1/4W	
R10	22k	Metal film resistor, 1/4W	
R11	100k	Metal film resistor, 1/4W	
R12	470k	Metal film resistor, 1/4W	
R13	120R	Metal film resistor, 1/4W	
R14	1k	Metal film resistor, 1/4W	
R15	10k	Metal film resistor, 1/4W	
R16	68k	Metal film resistor, 1/4W	
R17	220k	Metal film resistor, 1/4W	
R18	47k	Metal film resistor, 1/4W	
R19	10k	Metal film resistor, 1/4W	
R20	10k	Metal film resistor, 1/4W	
R21	68k	Metal film resistor, 1/4W	
R22	3k3	Metal film resistor, 1/4W	
R23	3k3	Metal film resistor, 1/4W	
R24	10k	Metal film resistor, 1/4W	
R25	100k	Metal film resistor, 1/4W	
R26	330R	Metal film resistor, 1/4W	
R27	82k	Metal film resistor, 1/4W	
R28	330R	Metal film resistor, 1/4W	
R29	100k	Metal film resistor, 1/4W	
R30	330R	Metal film resistor, 1/4W	

## PARTS LIST, CONT.

PART	VALUE	TYPE	NOTES
R31	10k	Metal film resistor, 1/4W	
R32	10k	Metal film resistor, 1/4W	
R33	470k	Metal film resistor, 1/4W	
R34	10k	Metal film resistor, 1/4W	
R35	1k	Metal film resistor, 1/4W	
R36	100k	Metal film resistor, 1/4W	
RPD	2M2	Metal film resistor, 1/4W	Input pulldown resistor. Can be as low as 1M.
LEDR	4k7	Metal film resistor, 1/4W	LED current-limiting resistor. Adjust value to change LED brightness.
C1	47n	Film capacitor, 7.2 x 2.5mm	
C2	47n	Film capacitor, 7.2 x 2.5mm	
C3	100pF	MLCC capacitor, NP0/C0G	
C4	47uF	Electrolytic capacitor, 5mm	
C5	10uF	Electrolytic capacitor, 5mm	
C6	47n	Film capacitor, 7.2 x 2.5mm	
C7	100pF	MLCC capacitor, NP0/C0G	
C8	100pF	MLCC capacitor, NP0/C0G	
C9	47n	Film capacitor, 7.2 x 2.5mm	
C10	1uF	Film capacitor, 7.2 x 3.5mm	
C11	1n	Film capacitor, 7.2 x 2.5mm	
C12	1uF	Film capacitor, 7.2 x 3.5mm	
C13	470pF	MLCC capacitor, NP0/C0G	
C14	10uF	Electrolytic capacitor, 5mm	
C15	1.5uF	Film capacitor, 7.2 x 4.5mm	
C16	68n	Film capacitor, 7.2 x 2.5mm	
C17	150n	Film capacitor, 7.2 x 2.5mm	
C18	6n8	Film capacitor, 7.2 x 2.5mm	
C19	100n	Film capacitor, 7.2 x 2.5mm	
C20	4n7	Film capacitor, 7.2 x 2.5mm	
C21	47n	Film capacitor, 7.2 x 2.5mm	
C22	1uF	Film capacitor, 7.2 x 3.5mm	
C23	100uF	Electrolytic capacitor, 6.3mm	Power supply filter capacitor.
C24	47uF	Electrolytic capacitor, 5mm	Voltage reference filter capacitor.
C25	100n	MLCC capacitor, X7R	Power supply filter capacitor.

## PARTS LIST, CONT.

PART	VALUE	TYPE	NOTES
D1	1N5817	Schottky diode, DO-41	Polarity protection diode with low voltage drop (~0.2V).
D2	1N914	Fast-switching diode, DO-35	
D3	1N914	Fast-switching diode, DO-35	
D4	1N914	Fast-switching diode, DO-35	
D5	BAT46	Schottky diode, DO-35	The HM-2 uses Ge diodes here, but Schottky is a better modern replacement. They only set the gate threshold and do not affect tone.
D6	BAT46	Schottky diode, DO-35	
D8	1N914	Fast-switching diode, DO-35	
D9	1N914	Fast-switching diode, DO-35	
Q1	2N5457	JFET, N-channel, TO-92	The HM-2 uses 2SK30A-Y (a Japanese equivalent).
Q2	2N5088	BJT transistor, NPN, TO-92	The HM-2 uses 2SC2240-GR (a Japanese equivalent).
Q3	2N5087	BJT transistor, PNP, TO-92	The HM-2 uses 2SA970-GR (a Japanese equivalent).
Q4	2N5088	BJT transistor, NPN, TO-92	The HM-2 uses 2SC732TM-GR (a Japanese equivalent).
IC1	JRC4558D	Operational amplifier, DIP8	
IC2	JRC4558D	Operational amplifier, DIP8	
IC3	JRC4558D	Operational amplifier, DIP8	
IC1-S	DIP-8 socket	IC socket, DIP-8	
IC2-S	DIP-8 socket	IC socket, DIP-8	
IC3-S	DIP-8 socket	IC socket, DIP-8	
LED	5mm	LED, 5mm	Adjust LEDR resistor to set brightness depending on the LED used.
VOL	10kA	Potentiometer, 16mm right-angle	Audio (log) taper.
DIST	250kA	Potentiometer, 16mm right-angle	Audio (log) taper. The HM-2 uses D-taper which is similar to A.
HIGH	10kA	Potentiometer, 16mm right-angle	Audio (log) taper. The HM-2 uses G-taper which is similar to A.
LOW	10kA	Potentiometer, 16mm right-angle	Audio (log) taper. The HM-2 uses G-taper which is similar to A.
IN	1/4" mono	1/4" phone jack, closed frame	Switchcraft 111X or equivalent. Open-frame types can be used instead, but the top side drill template is different. See drill template for details.
OUT	1/4" mono	1/4" phone jack, closed frame	
DC	2.1mm	DC jack, 2.1mm panel mount	Mouser 163-4302-E or equivalent.
FSW	3PDT	3PDT stomp switch	
ENC	125B	Enclosure, die-cast aluminum	Can also use a Hammond 1590N1.

## BUILD NOTES

---

### The “midrange” control modification

Many people who have looked at the schematic of the HM-2 have noticed that there are three distinct EQ poles (technically op-amp gyrators), but two of them are tied together to make the High control. As a result, a common modification is to split out this EQ pole into its own knob, which is mistakenly called a midrange knob because it controls a slightly lower frequency than the high control. People see this and begin to think they’ve uncovered some super-secret control that had to be hidden because it was just too brutal or something.

While the Graviton project does support splitting out this 3rd EQ pole into its own control, I’m going to try to dissuade you from it. The reason is that the two EQ poles are centered very closely together around **1kHz** and **1.2kHz**, and they overlap in such a way as to form a single filter that is just broader than normal. By breaking out control over 1k but leaving 1.2k intact, you end up with a really weird notch effect that isn’t very useful, while also changing the core tone characteristics of the HM-2.

**With that out of the way:** to use the midrange pot, you will need to cut a trace on the PCB. On the back of the PCB, between lugs 1 & 2 of the “High” pot, you’ll see two diagonal marks:

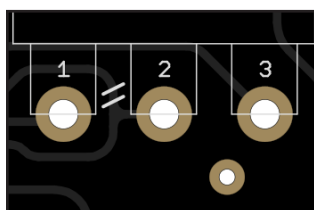

If you cut the trace at exactly this spot, taking care to avoid all surrounding traces, you can solder a 10kA pot to the “MID” pads in the middle. We recommend using an Alpha right-angle 9mm pot as shown to the right, but with the side mounting pins clipped off.



### Adjusting the EQ filters

If you want to experiment and don’t care about maintaining the stock HM-2 tone, you can turn this filter into a truly useful midrange control. By changing some part values in the “mid” EQ pole, you can lower the gyrator frequency into something that would be worth splitting out.

For instance, if you put it down into the 720Hz range, you’d have control over the classic Tube Screamer mid frequency, which also happens to be right between the 86 Hz frequency of the Low knob and the 1.2k frequency of the High knob. To do this, you’d change **R27** to **100k** and **C18** to **10n**.

For further experimentation, we recommend using [AMZ’s Bandpass EQ calculator](#).

### Bypassing the output buffer

The output of the HM-2 is already well-buffered, but there is a second transistor-based buffer added to the end to support the JFET switching. To be as true to the original as possible, this second buffer has been included in the Graviton even though the JFET switching is omitted. Jumper pads are provided in the upper-right corner of the PCB to bypass this last buffer if desired. If you do use the jumper, you can omit **C21**, **C22**, **R33**, **R34**, **R35**, and **Q4**.

# SCHEMATIC

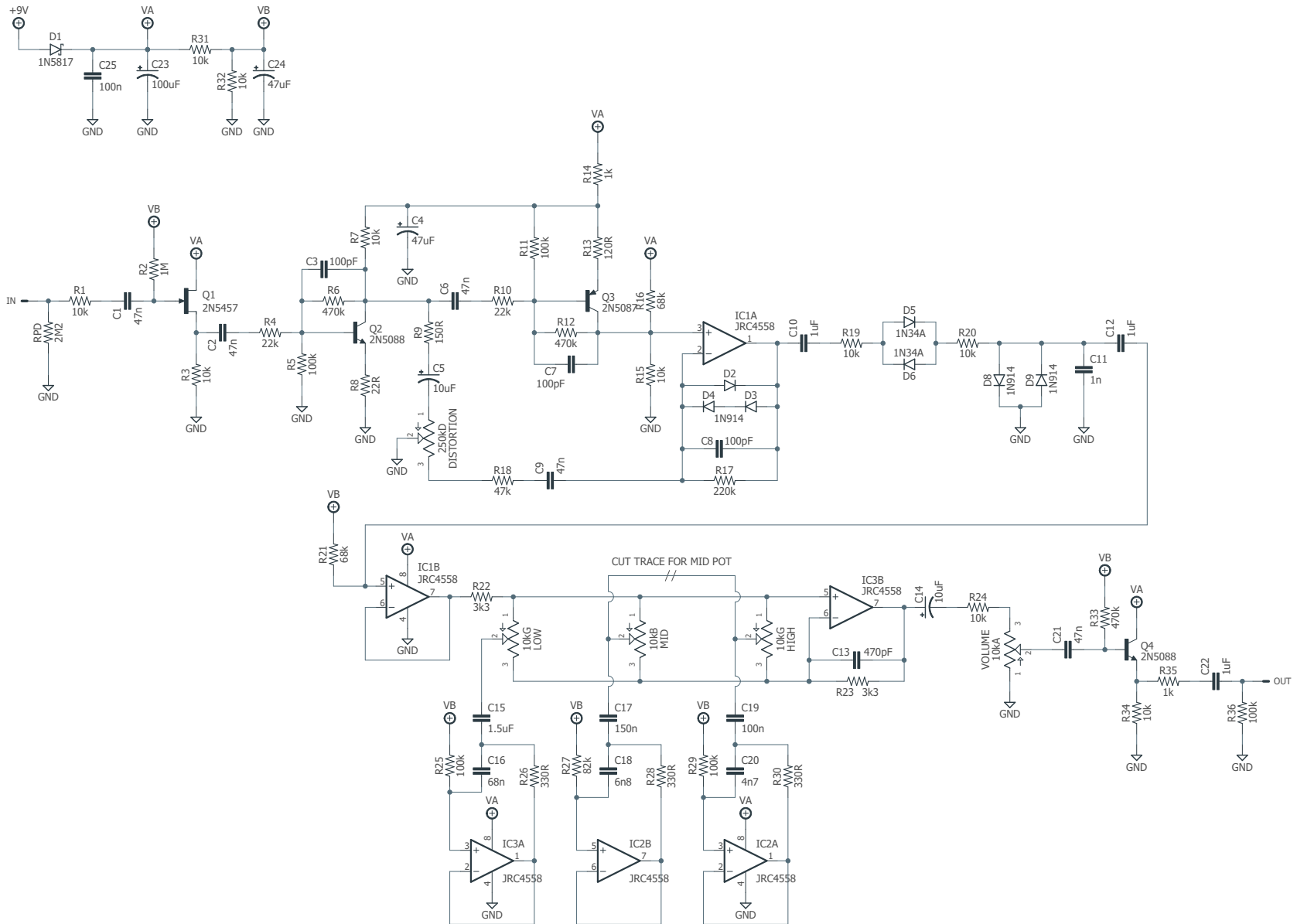

# DRILL TEMPLATE

Cut out this drill template, fold the edges and tape it to the enclosure. Before drilling, it's recommended to first use a center punch for each of the holes to help guide the drill bit.

Ensure that this template is printed at 100% or "Actual Size". You can double-check this by measuring the scale on the printed page.

**Top jack layout** assumes the use of closed-frame jacks like the [Switchcraft 111X](#). If you'd rather use open-frame jacks, please refer to the [Open-Frame Jack Drill Template](#) for the top side.

**LED hole drill size** assumes the use of a [5mm LED bezel](#), available from several parts suppliers. Adjust size accordingly if using something different, such as a 3mm bezel, a plastic bezel, or just a plain LED.

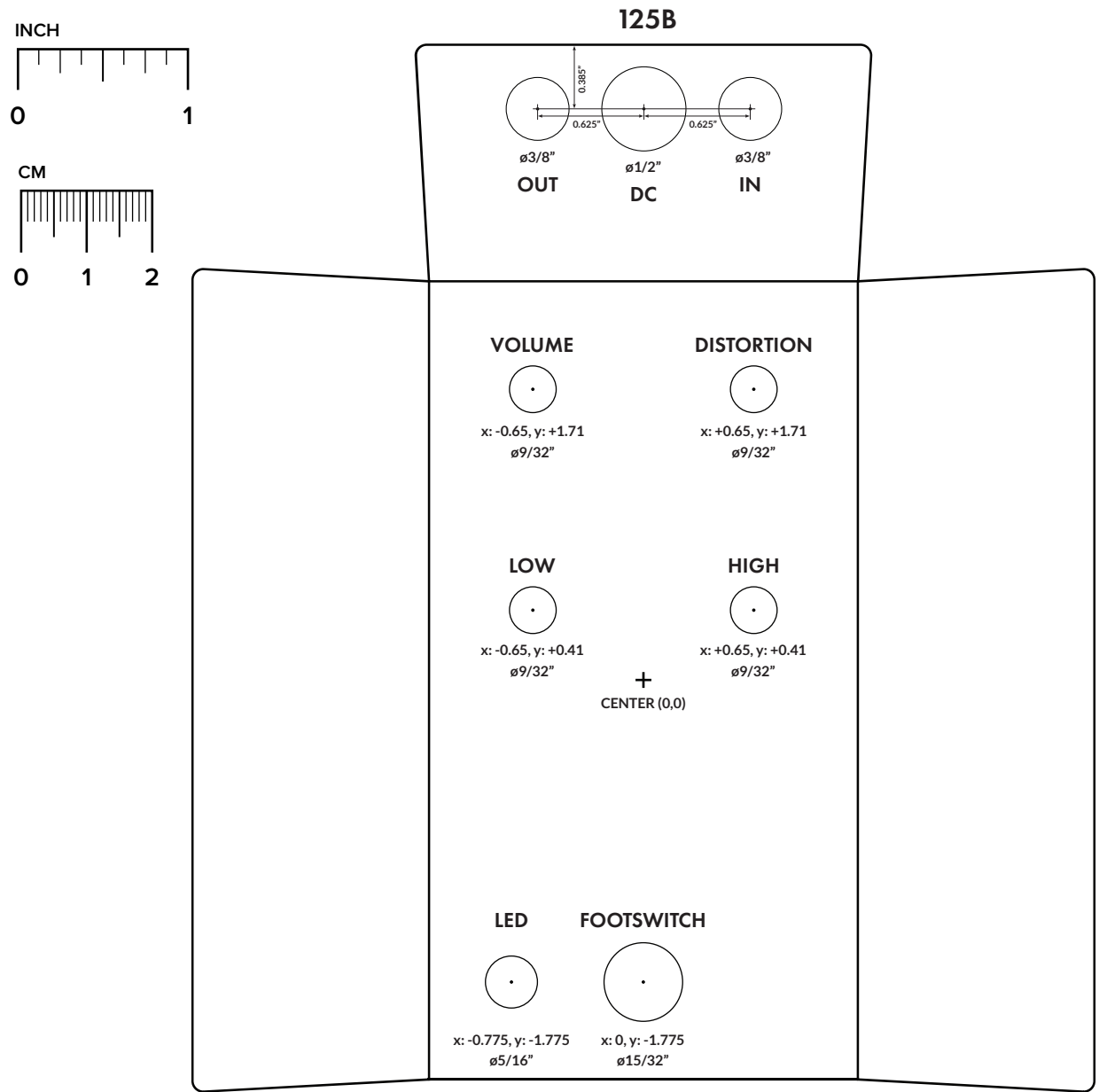



# ENCLOSURE LAYOUT

---

Enclosure is shown without jacks. See next page for jack layout and wiring.

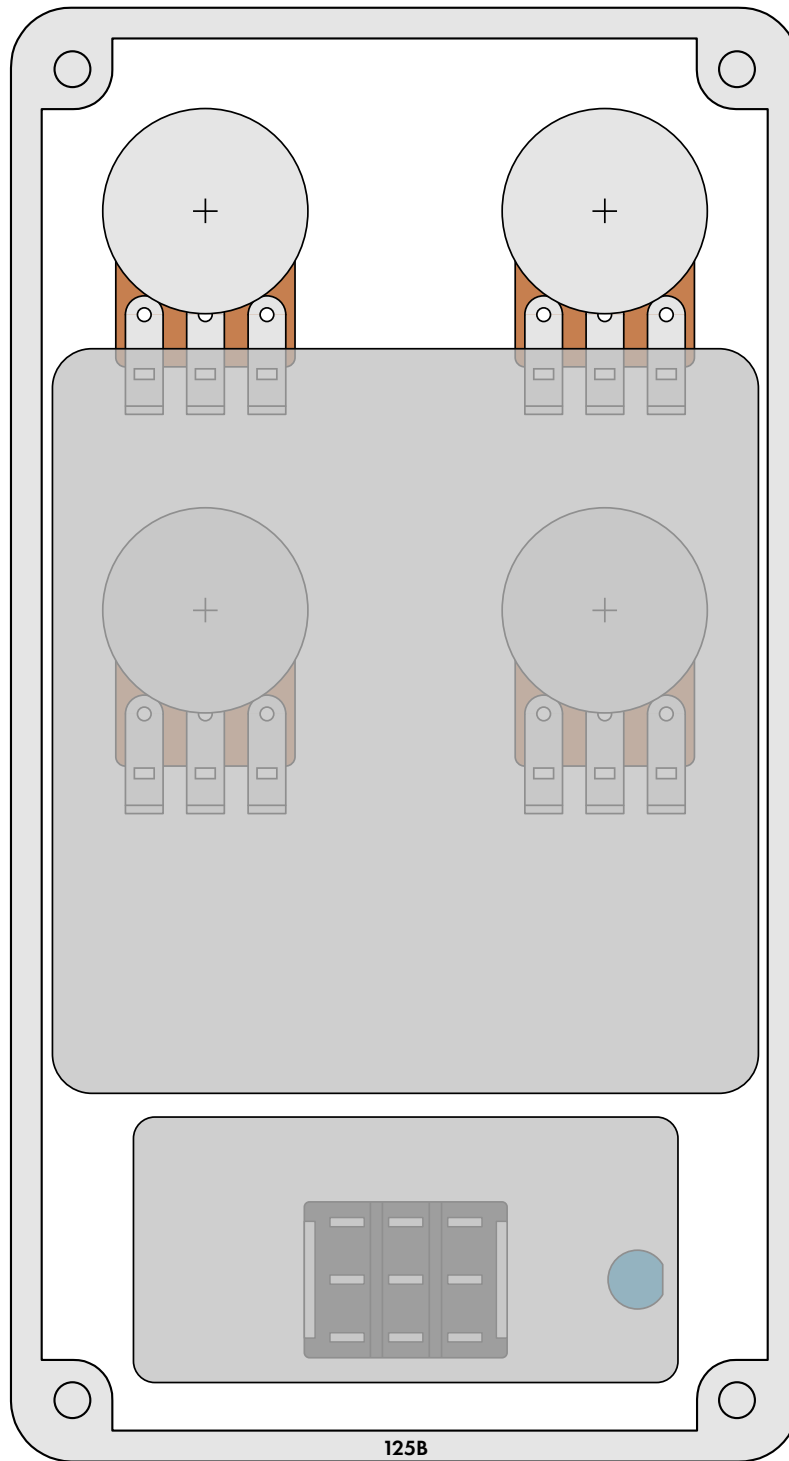

# WIRING DIAGRAM

---

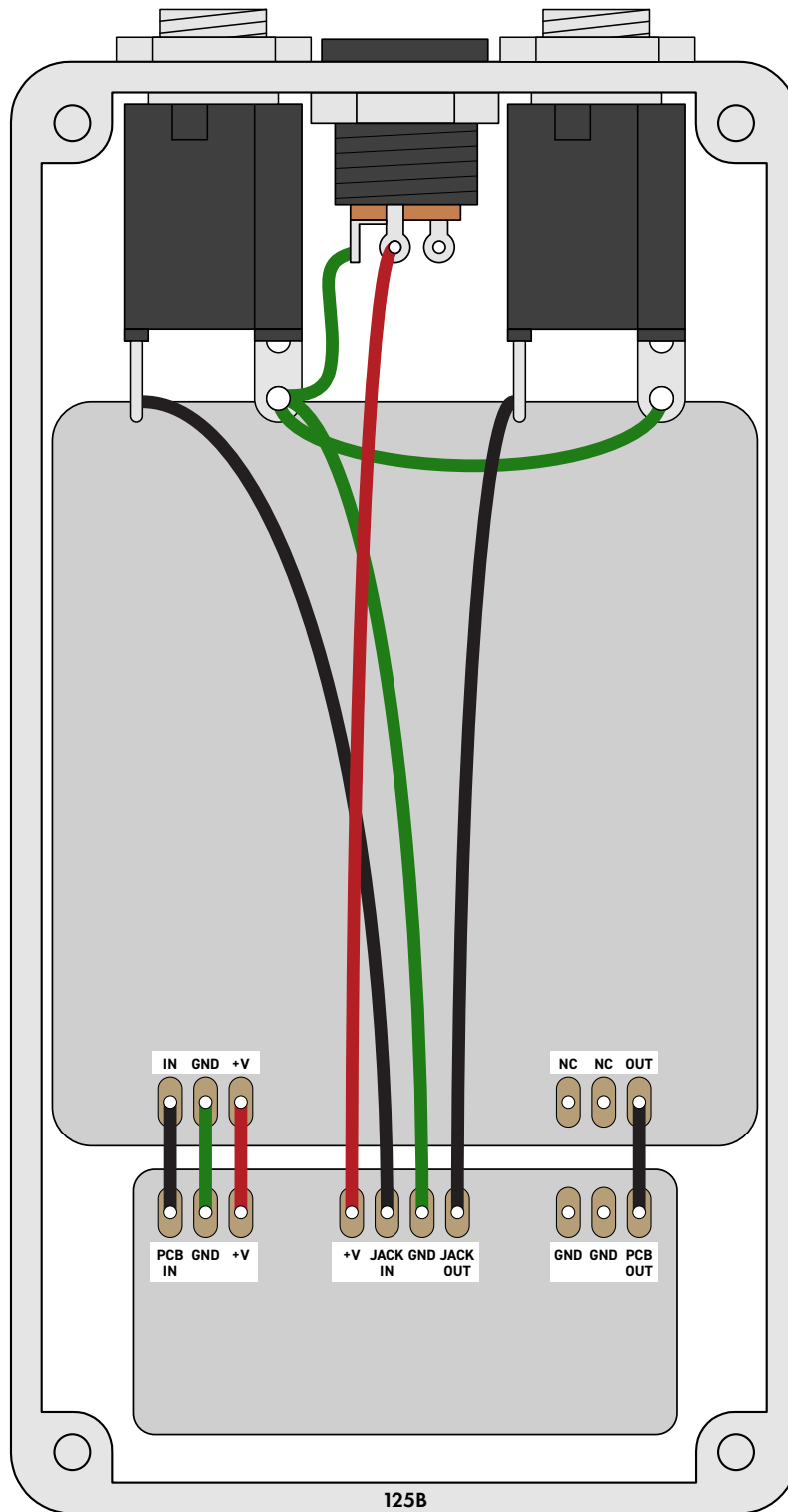

## LICENSE & USAGE

---

**No direct support is offered for these projects beyond the provided documentation.** It's assumed that you have at least some experience building pedals before starting one of these. Replacements and refunds cannot be offered unless it can be shown that the circuit or documentation are in error.

**All of these circuits have been tested in good faith in their base configurations.** However, not all the modifications or variations have necessarily been tested. These are offered only as suggestions based on the experience and opinions of others.

## DOCUMENT REVISIONS

---

### **1.1.0 (2019-08-06)**

Added C25 (100n ceramic capacitor) for extra power filtering to make it consistent with other Aion FX PCBs. Slight layout tweak to move the D1 polarity-protection diode to the footswitch PCB.

### **1.0.0 (2018-07-04)**

Initial release.