

PROJECT NAME

EMPYREAN DELUXE



BASED ON

Darkglass® Alpha Omega

BUILD DIFFICULTY



EFFECT TYPE

Bass distortion / EQ

DOCUMENT VERSION

1.0.0 (2025-03-28)

PROJECT SUMMARY

A dual-mode bass distortion that delivers modern rock & metal bass tones by way of carefully-tuned signal filtering, plus a clean blend to retain the low end. Also includes a 3-band EQ for more flexible control of the blended tone.

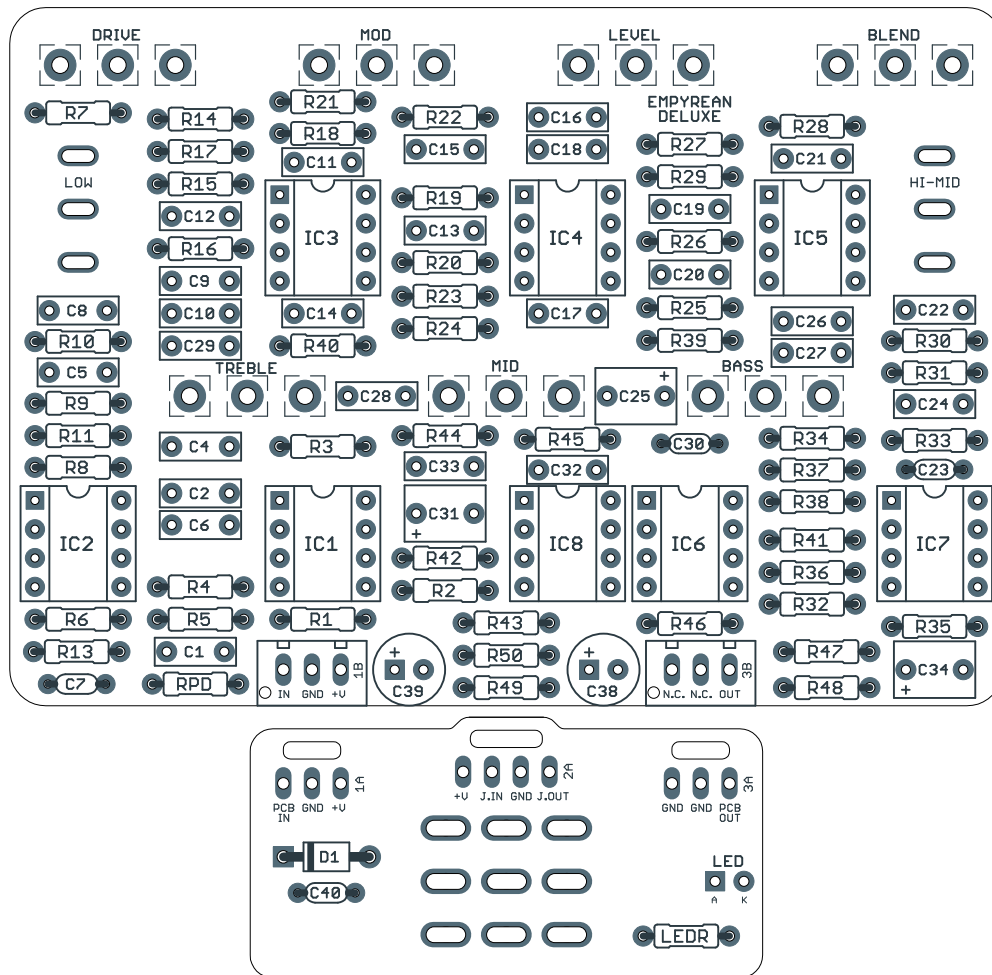

Actual size is 3.44" x 2.42" (main board) and 1.77" x 0.87" (bypass board).

TABLE OF CONTENTS

1	Project Overview	9	Drill Template
2	Introduction & Usage	10	Enclosure Layout
3-6	Parts List	11	Wiring Diagram
7	Build Notes	12	Licensing
8	Schematic	12	Document Revisions

INTRODUCTION

The Empyrean Deluxe Distortion is based on the Darkglass Alpha Omega, a dual-engine bass distortion designed in collaboration with Jon Stockman, bassist of the Australian progressive band Karnivool. It was first released in 2017 and [traced by Aion FX in 2025](#).

The Alpha Omega is an upgraded version of the Alpha Omicron (which we also traced and released as the standard Empyrean) in the same way that the B7K is an upgraded B3K. The core circuit is the same, but a 3-band EQ has been added to the end of the Omega and B7K so it acts more like a full preamp than a straightforward drive pedal.

The Alpha Omega & Omicron have many similarities to the B3K and Duality, featuring several shared design elements that have become Darkglass signatures. But the two distortion sections (called Alpha and Omega) are unique to this pedal, and there are no overdriven CMOS stages like the B3K or Duality.

After some standard tone shaping, the signal is split into two paths. The Alpha path is described as punchy and tight, while the Omega path is described as brutal and raw. The “Mod” control blends between the two. Then, as with the other Darkglass circuits, there’s a clean blend to mix in the dry signal.

The Empyrean Deluxe is a direct adaptation of the Alpha Omega based on our trace, minus the XLR output. It’s been converted to true bypass, but the effect signal path is the same.

USAGE

The Empyrean Deluxe has seven knobs and two toggle switches:

- **Drive** controls the amount of gain from the op-amp that is fed through the two distortion stages.
- **Mod** pans between “Alpha” (more filtered and refined) and “Omega” (more raw) distortion circuits.
- **Level** sets the overall output of the drive signal before the clean blend.
- **Blend** pans between the buffered clean signal and the drive signal.
- **Bass, Mid** and **Treble** form a 3-band EQ that comes after the blend, allowing frequencies to be boosted or cut by 12dB at 80 Hz, 500 Hz, and 5kHz, with a flat response in the 12:00 position.
- **Low** (toggle) adds bass frequencies before the op-amp gain stage.
- **Hi-Mid** (toggle) engages a 2.8k midrange boost.

PARTS LIST

This parts list is also available in a spreadsheet format which can be imported directly into Mouser for easy parts ordering. Mouser doesn't carry all the parts—notably potentiometers—so the second tab lists all the non-Mouser parts as well as sources for each.

[View parts list spreadsheet](#) →

PART	VALUE	TYPE	NOTES
R1	10k	Metal film resistor, 1/4W	
R2	1M	Metal film resistor, 1/4W	
R3	10k	Metal film resistor, 1/4W	
R4	100k	Metal film resistor, 1/4W	
R5	220k	Metal film resistor, 1/4W	
R6	220k	Metal film resistor, 1/4W	
R7	2k2	Metal film resistor, 1/4W	
R8	2k2	Metal film resistor, 1/4W	
R9	100k	Metal film resistor, 1/4W	
R10	100k	Metal film resistor, 1/4W	
R11	47k	Metal film resistor, 1/4W	
R13	300k	Metal film resistor, 1/4W	
R14	3k3	Metal film resistor, 1/4W	
R15	8k06	Metal film resistor, 1/4W	Can substitute 8k2, used in the Alpha Omicron.
R16	150k	Metal film resistor, 1/4W	
R17	10k	Metal film resistor, 1/4W	
R18	10k	Metal film resistor, 1/4W	
R19	10k	Metal film resistor, 1/4W	
R20	47k	Metal film resistor, 1/4W	
R21	47k	Metal film resistor, 1/4W	
R22	47k	Metal film resistor, 1/4W	
R23	10k	Metal film resistor, 1/4W	
R24	47k	Metal film resistor, 1/4W	
R25	22k	Metal film resistor, 1/4W	
R26	47k	Metal film resistor, 1/4W	
R27	10k	Metal film resistor, 1/4W	
R28	10k	Metal film resistor, 1/4W	
R29	20k	Metal film resistor, 1/4W	
R30	10k	Metal film resistor, 1/4W	
R31	10k	Metal film resistor, 1/4W	
R32	56k	Metal film resistor, 1/4W	
R33	10k	Metal film resistor, 1/4W	

PARTS LIST, CONT.

PART	VALUE	TYPE	NOTES
R34	10k	Metal film resistor, 1/4W	
R35	10k	Metal film resistor, 1/4W	
R36	10k	Metal film resistor, 1/4W	
R37	10k	Metal film resistor, 1/4W	
R38	10k	Metal film resistor, 1/4W	
R39	10k	Metal film resistor, 1/4W	
R40	3k3	Metal film resistor, 1/4W	
R41	1M	Metal film resistor, 1/4W	
R42	220k	Metal film resistor, 1/4W	
R43	220k	Metal film resistor, 1/4W	
R44	2k2	Metal film resistor, 1/4W	
R45	2k2	Metal film resistor, 1/4W	
R46	1M	Metal film resistor, 1/4W	
R47	100k	Metal film resistor, 1/4W	
R48	1k	Metal film resistor, 1/4W	
R49	10k	Metal film resistor, 1/4W	
R50	10k	Metal film resistor, 1/4W	
RPD	2M2	Metal film resistor, 1/4W	Input pull-down resistor.
LEDR	10k	Metal film resistor, 1/4W	LED current-limiting resistor. Adjust value to change LED brightness.
C1	100n	Film capacitor, 7.2 x 2.5mm	
C2	22n	Film capacitor, 7.2 x 2.5mm	
C4	68n	Film capacitor, 7.2 x 2.5mm	
C5	1n	Film capacitor, 7.2 x 2.5mm	
C6	10n	Film capacitor, 7.2 x 2.5mm	
C7	47pF	MLCC capacitor, NP0/COG	
C8	100n	Film capacitor, 7.2 x 2.5mm	
C9	2n2	Film capacitor, 7.2 x 2.5mm	
C10	22n	Film capacitor, 7.2 x 2.5mm	
C11	1n	Film capacitor, 7.2 x 2.5mm	
C12	1n	Film capacitor, 7.2 x 2.5mm	
C13	1n	Film capacitor, 7.2 x 2.5mm	
C14	1n	Film capacitor, 7.2 x 2.5mm	
C15	2n2	Film capacitor, 7.2 x 2.5mm	
C16	22n	Film capacitor, 7.2 x 2.5mm	
C17	1n	Film capacitor, 7.2 x 2.5mm	
C18	1n	Film capacitor, 7.2 x 2.5mm	
C19	2n2	Film capacitor, 7.2 x 2.5mm	

PARTS LIST, CONT.

PART	VALUE	TYPE	NOTES
C20	1n	Film capacitor, 7.2 x 2.5mm	
C21	6n8	Film capacitor, 7.2 x 2.5mm	
C22	120n	Film capacitor, 7.2 x 2.5mm	
C23	270pF	MLCC capacitor, NP0/C0G	
C24	270n	Film capacitor, 7.2 x 3.5mm	
C25	2.2uF	Film capacitor, 7.2 x 5mm	
C26	22n	Film capacitor, 7.2 x 2.5mm	
C27	22n	Film capacitor, 7.2 x 2.5mm	
C28	10n	Film capacitor, 7.2 x 2.5mm	
C29	10n	Film capacitor, 7.2 x 2.5mm	
C30	33pF	MLCC capacitor, NP0/C0G	
C31	2.2uF	Film capacitor, 7.2 x 5mm	
C32	2n2	Film capacitor, 7.2 x 2.5mm	
C33	22n	Film capacitor, 7.2 x 2.5mm	
C34	2.2uF	Film capacitor, 7.2 x 5mm	
C38	100uF	Electrolytic capacitor, 6.3mm	Reference voltage filter capacitor.
C39	220uF	Electrolytic capacitor, 6.3mm	Power supply filter capacitor.
C40	100n	MLCC capacitor, X7R	Power supply filter capacitor.
D1	1N5817	Schottky diode, DO-41	
IC1	RC4559P	Operational amplifier, dual, DIP8	
IC1-S	DIP-8 socket	IC socket, DIP-8	
IC2	TL072	Operational amplifier, dual, DIP8	
IC2-S	DIP-8 socket	IC socket, DIP-8	
IC3	RC4559P	Operational amplifier, dual, DIP8	
IC3-S	DIP-8 socket	IC socket, DIP-8	
IC4	RC4559P	Operational amplifier, dual, DIP8	
IC4-S	DIP-8 socket	IC socket, DIP-8	
IC5	RC4559P	Operational amplifier, dual, DIP8	
IC5-S	DIP-8 socket	IC socket, DIP-8	
IC6	RC4559P	Operational amplifier, dual, DIP8	
IC6-S	DIP-8 socket	IC socket, DIP-8	
IC7	RC4559P	Operational amplifier, dual, DIP8	
IC7-S	DIP-8 socket	IC socket, DIP-8	
IC8	RC4559P	Operational amplifier, dual, DIP8	
IC8-S	DIP-8 socket	IC socket, DIP-8	
DRIVE	100kC	16mm right-angle PCB mount pot	Reverse audio (reverse log or antilog) taper.
MOD	100kB	16mm right-angle PCB mount pot	Linear taper.

PARTS LIST, CONT.

PART	VALUE	TYPE	NOTES
LEVEL	100kA	16mm right-angle PCB mount pot	Audio (log) taper.
BLEND	100kB	16mm right-angle PCB mount pot	Linear taper.
BASS	100kB	16mm right-angle PCB mount pot	Linear taper.
MID	100kB	16mm right-angle PCB mount pot	Linear taper.
TREBLE	100kB	16mm right-angle PCB mount pot	Linear taper.
LOW	SPDT on-on	Toggle switch, SPDT on-on	
HI-MID	SPDT on-on	Toggle switch, SPDT on-on	
LED	5mm	LED, 5mm, red diffused	
IN	1/4" mono	1/4" phone jack, closed frame	Switchcraft 111X or equivalent.
OUT	1/4" mono	1/4" phone jack, closed frame	Switchcraft 111X or equivalent.
DC	2.1mm	DC jack, 2.1mm panel mount	Mouser 163-4302-E or equivalent.
FSW	3PDT	Stomp switch, 3PDT	
ENC	1590BBS	Enclosure, die-cast aluminum	

BUILD NOTES

IC selection

The original Alpha Omicron uses the MC33178 for IC1 and IC3-7. This op-amp is a favorite of Darkglass, used in nearly all of their pedals in some capacity.

For the Omega/Omicron circuits in particular, the the distortion comes from overdriving the op-amps directly, so selection is important, and different op-amps may have wildly different characteristics when overdriven.

The 33178 is an older op-amp, still readily available in SMD format but nearly impossible to find in DIP. We cross-referenced datasheets for dozens of different audio op-amps and found that the **RC4559P** is a near-exact match.

It could be the case that they are truly identical and that the slight differences are due to different measurement techniques between ONSem and Texas Instruments. But either way, it's very close in the ways that matter—slew rate, noise figure, and gain-bandwidth product—and in our testing it sounded the same.

C25 and C31 capacitor values

In the original Alpha Omega, C25 and C31 are bipolar 10uF capacitors. These values are much larger than necessary for full-frequency operation, so we've substituted them with 2.2uF film capacitors.

If you want to use 10uF capacitors in these positions, you can either use bipolar electrolytics, in which case the polarity does not matter, or polarized electrolytics, in which case the positive pin is marked in the outline of the film capacitor. The polarity marker is only important in the case of polarized electrolytics and can be ignored otherwise.

C34 capacitor value

C34 (the output capacitor) is 1uF in the original. This is probably fine in nearly all situations, but since the output capacitor interacts with the input capacitor of what follows, it's recommended to increase the value to 2.2uF.

If you want to increase it even further, polarity marks have been added to the footprint, but these should be ignored unless using a polarized capacitor.

Enclosure size

This project was designed for the **Hammond 1590BBS** enclosure, which has the same height as the 125B or 1590N1.

If you don't use the Hammond brand, be careful—not all 1590BBS enclosures are the same. For example, Love My Switches sells two different types, and the [CNC Pro](#) version is correct while the standard one is too short.

SCHEMATIC

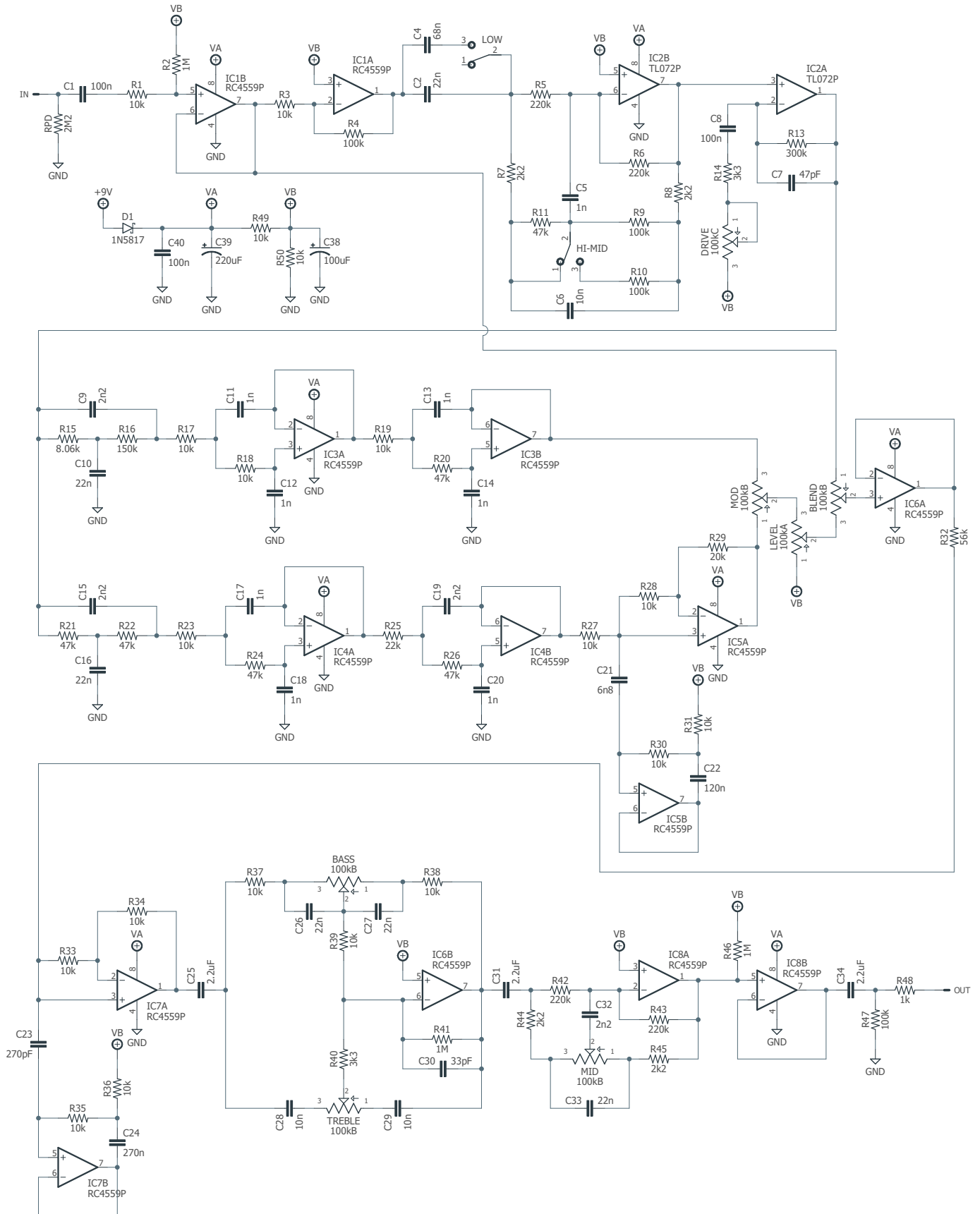

DRILL TEMPLATE

Cut out this drill template, fold the edges and tape it to the enclosure. Before drilling, it's recommended to first use a center punch for each of the holes to help guide the drill bit.

Ensure that this template is printed at 100% or "Actual Size". You can double-check this by measuring the scale on the printed page.

Top jack layout assumes the use of closed-frame jacks like the [Switchcraft 111X](#). Open-frame jacks will work as well, but you may need to experiment with the rotation so the tip isn't at risk of shorting against the enclosure or any components when a plug is inserted.

LED hole drill size assumes the use of a [5mm LED bezel](#), available from several parts suppliers. Adjust size accordingly if using something different, such as a 3mm bezel, a plastic bezel, or just a plain LED.

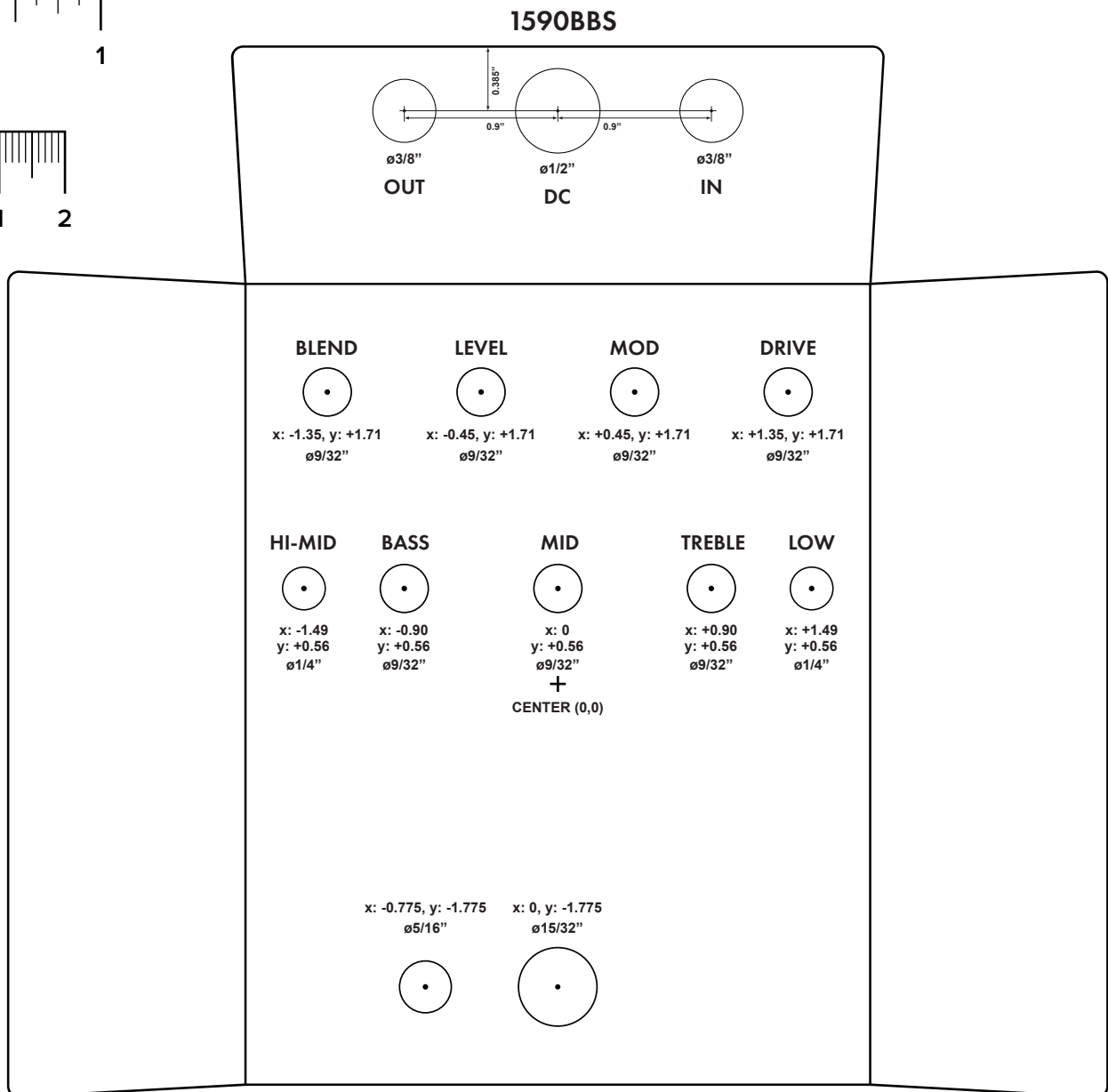
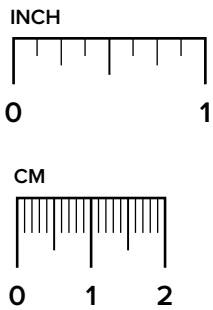

ENCLOSURE LAYOUT

Enclosure is shown without jacks. See next page for jack layout and wiring.

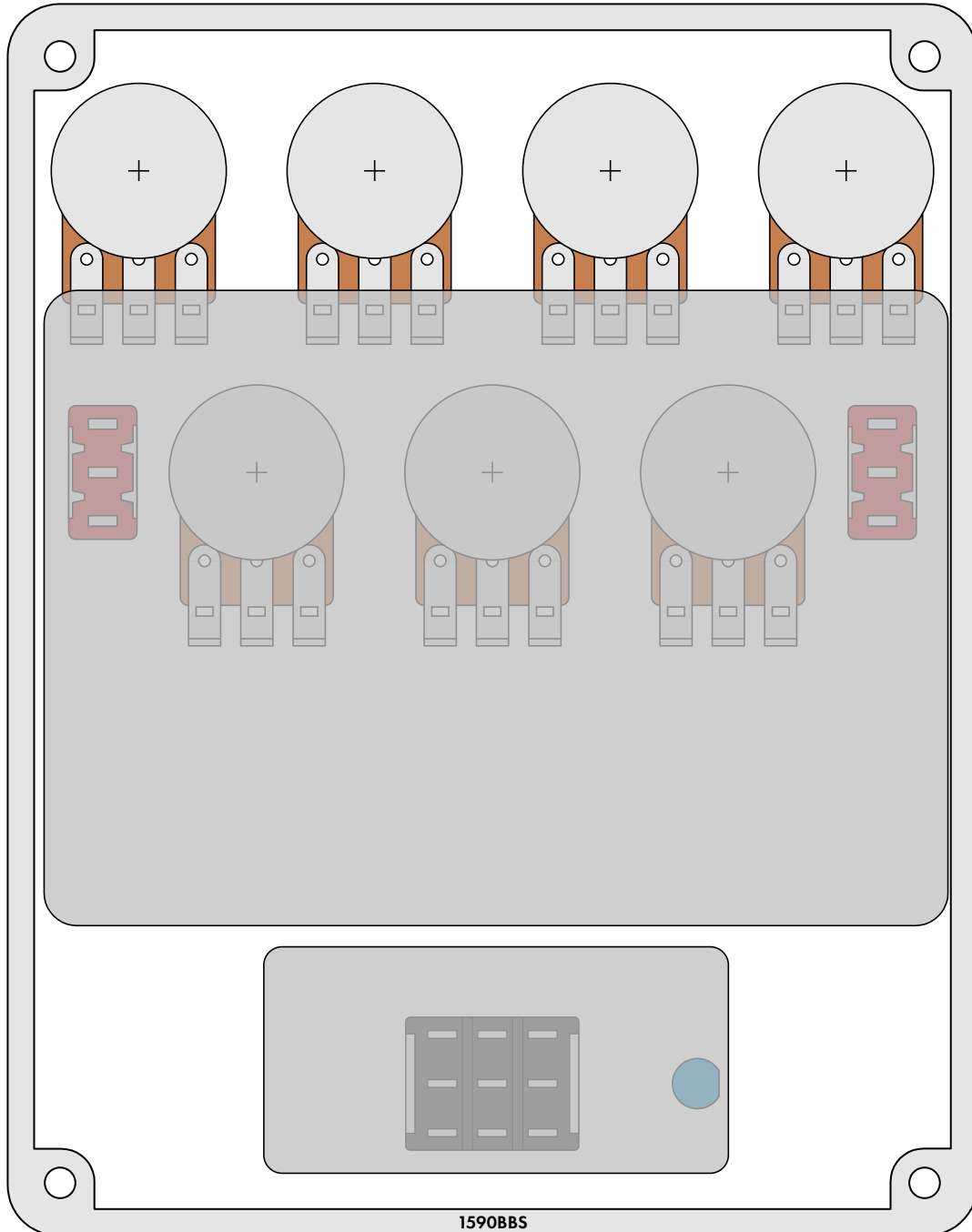

WIRING DIAGRAM

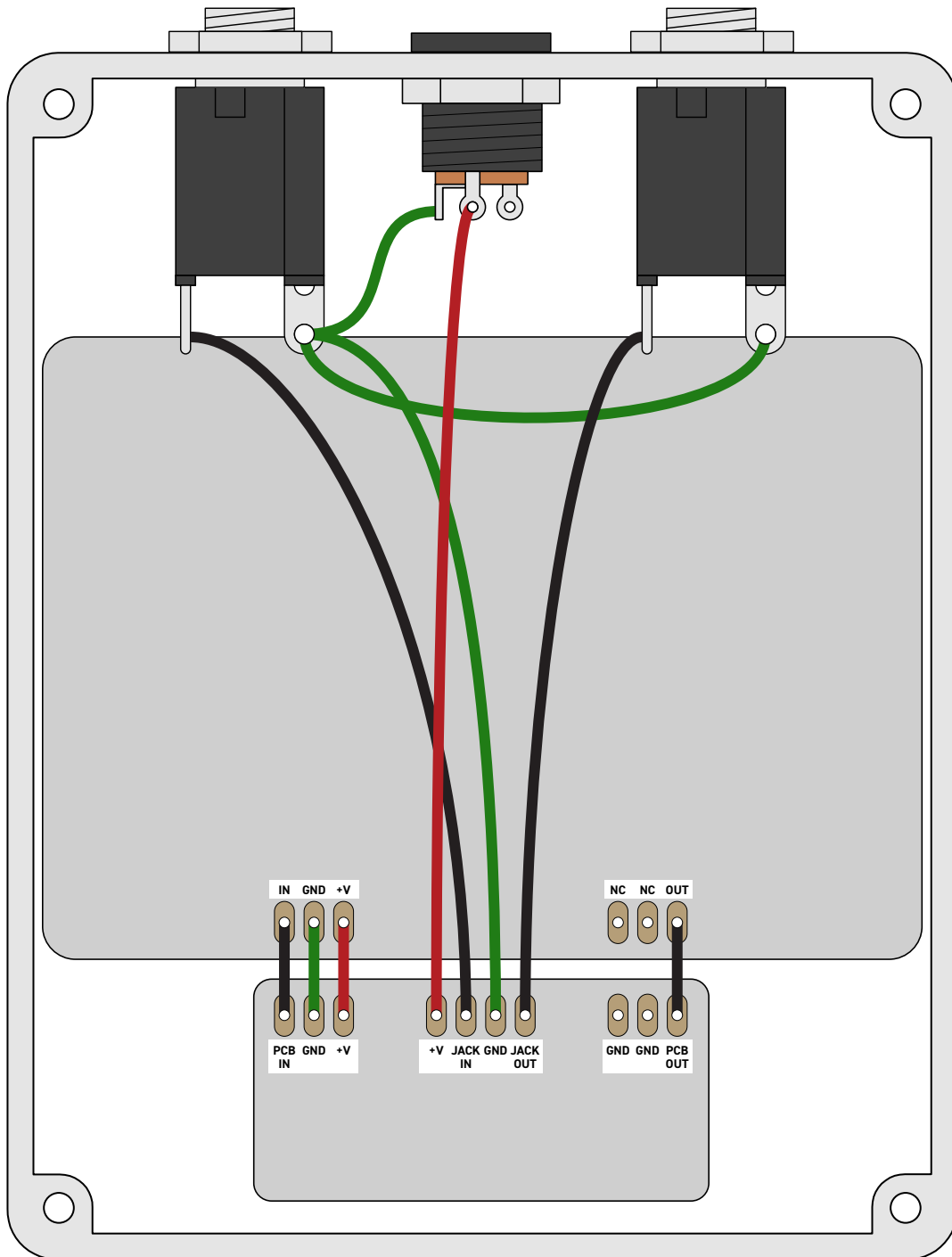

LICENSE & USAGE

No direct support is offered for these projects beyond the provided documentation. It's assumed that you have at least some experience building pedals before starting one of these. Replacements and refunds cannot be offered unless it can be shown that the circuit or documentation are in error.

All of these circuits have been tested in good faith in their base configurations. However, not all the modifications or variations have necessarily been tested. These are offered only as suggestions based on the experience and opinions of others.

Projects may be used for commercial endeavors in any quantity unless specifically noted. No attribution is necessary, though a link back is always greatly appreciated. The only usage restrictions are that **(1) you cannot resell the PCB as part of a kit without prior arrangement, and (2) you cannot "goop" the circuit, scratch off the screenprint, or otherwise obfuscate the circuit to disguise its source.** (In other words: you don't have to go out of your way to advertise the fact that you use these PCBs, but please don't go out of your way to hide it. The guitar effects industry needs more transparency, not less!)

DOCUMENT REVISIONS

1.0.0 (2025-03-28)

Initial release.