

PROJECT NAME

# CERULEAN

BASED ON

Marshall Bluesbreaker

EFFECT TYPE

Amp-Like Overdrive

BUILD DIFFICULTY

■■■■■ Easy

DOCUMENT VERSION

1.1.0 (2020-05-18)



## PROJECT SUMMARY

A classic overdrive effect that was designed to mimic the Marshall Bluesbreaker amplifier from the 1960s, the Bluesbreaker is also the source circuit for a number of high-dollar “boutique” guitar pedals.

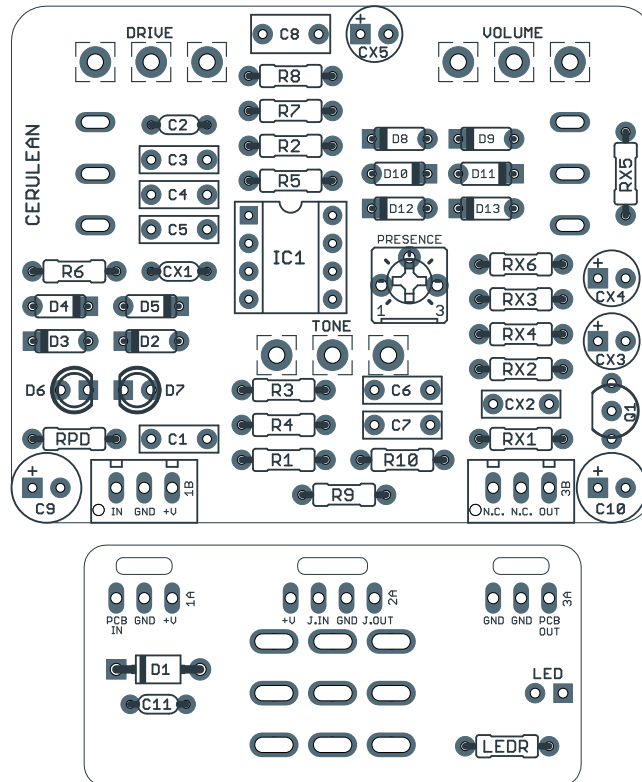

Actual size is 2.3" x 1.86" (main board) and 2.3" x 0.86" (bypass board).

# TABLE OF CONTENTS

---

1	Project Overview	7	Drill Template
2	Introduction & Usage	8	Enclosure Layout
3-4	Parts List	9	Wiring Diagram
5	Build Notes	10	Licensing
6	Schematic	10	Document Revisions

## INTRODUCTION

---

The Cerulean Amp Overdrive is an updated version of the Marshall Bluesbreaker pedal. The Bluesbreaker is the source circuit for a number of expensive boutique pedals including the Analogman King of Tone (which is two Bluesbreakers in the same box with a few modifications).

The Cerulean project has integrated two of the modifications from the King of Tone: the Presence control (an internal trimmer) and the ability to control both the soft clipping (stock) and hard clipping diodes. The clipping switches have been expanded further to allow two different diode combinations for both hard and soft clipping, whereas the King of Tone only has “on” and “off” settings for each.

Another notable clone of the Bluesbreaker is the JHS Morning Glory, which added a JFET gain stage at the end for increased output volume. The Cerulean project provides the option of using the output stage of the Morning Glory. See the build notes for more information.

During the development of this updated version of the Cerulean, it was determined that the “Bright” switch of the Morning Glory was not very useful, especially when there was already a Tone control and an internal Presence control, both of which affect the high end. The original Bluesbreaker doesn’t filter out any of the treble in the clipping stage, so in fact the Morning Glory is really no brighter than a stock Bluesbreaker, and instead only adds the option to get darker. Accordingly, this option has been removed in favor of simplifying the decisionmaking process when deciding how to build it.

However, if you do want to make an exact clone of the Morning Glory including the Bright switch, you can use the earlier version of the Cerulean which will continue to be available for the foreseeable future.

## USAGE

---

The Bluesbreaker has the same control layout as most overdrive or distortion effects:

- **Tone** controls the treble response of the effect.
- **Drive** controls the amount of gain in the op-amp feedback diode clipping stage.
- **Volume** controls the overall output.
- An internal **Presence** control allows you to tweak the overall response of the tone knob.
- **Soft Clipping** lets you choose between stock clipping diodes, LEDs, or no soft clipping.
- **Hard Clipping** lets you select high-threshold hard clipping, low-threshold hard clipping, or none.

## PARTS LIST

This parts list is also available in a spreadsheet format which can be imported directly into Mouser for easy parts ordering. Mouser doesn't carry all the parts—notably potentiometers—so the second tab lists all the non-Mouser parts as well as sources for each.

[View parts list spreadsheet](#) →

PART	VALUE	TYPE	NOTES
R1	1M	Metal film resistor, 1/4W	
R2	3k3	Metal film resistor, 1/4W	
R3	4k7	Metal film resistor, 1/4W	
R4	10k	Metal film resistor, 1/4W	
R5	220k	Metal film resistor, 1/4W	
R6	6k8	Metal film resistor, 1/4W	
R7	1k	Metal film resistor, 1/4W	
R8	6k8	Metal film resistor, 1/4W	
R9	47k	Metal film resistor, 1/4W	
R10	47k	Metal film resistor, 1/4W	
RX1	100k	Metal film resistor, 1/4W	Part of the optional Morning Glory gain stage. (see build notes)
RX2	68k	Metal film resistor, 1/4W	Part of the optional Morning Glory gain stage. (see build notes)
RX3	1M	Metal film resistor, 1/4W	Part of the optional Morning Glory gain stage. (see build notes)
RX4	22k	Metal film resistor, 1/4W	Part of the optional Morning Glory gain stage. (see build notes)
RX5	12k	Metal film resistor, 1/4W	Part of the optional Morning Glory gain stage. (see build notes)
RX6	12k	Metal film resistor, 1/4W	Part of the optional Morning Glory gain stage. (see build notes)
RPD	2M2	Metal film resistor, 1/4W	Input pulldown resistor. Can be as low as 1M.
LEDR	4k7	Metal film resistor, 1/4W	LED current-limiting resistor. Adjust value to change LED brightness.
C1	10n	Film capacitor, 7.2 x 2.5mm	
C2	47pF	MLCC capacitor, NP0/COG	
C3	10n	Film capacitor, 7.2 x 2.5mm	
C4	10n	Film capacitor, 7.2 x 2.5mm	
C5	100n	Film capacitor, 7.2 x 2.5mm	
C6	10n	Film capacitor, 7.2 x 2.5mm	
C7	10n	Film capacitor, 7.2 x 2.5mm	
C8	100n	Film capacitor, 7.2 x 2.5mm	Omit if using Morning Glory gain stage. (see build notes)
C9	100uF	Electrolytic capacitor, 6.3mm	Power supply filter capacitor.
C10	47uF	Electrolytic capacitor, 6.3mm	Voltage reference filter capacitor.
C11	100n	MLCC capacitor, X7R	Power supply filter capacitor. Added in v1.1.
CX1	100pF	MLCC capacitor, NP0/COG	Optional high-frequency feedback capacitor.

## PARTS LIST, CONT.

PART	VALUE	TYPE	NOTES
CX2	100n	Film capacitor, 7.2 x 2.5mm	Part of the optional Morning Glory gain stage. (see build notes)
CX3	10uF	Electrolytic capacitor, 5mm	Part of the optional Morning Glory gain stage. (see build notes)
CX4	2.2uF	Electrolytic capacitor, 4mm	Part of the optional Morning Glory gain stage. (see build notes)
CX5	OMIT	Electrolytic capacitor, 4mm	1uF is used in the King of Tone variant.
D1	1N5817	Schottky diode, DO-41	
D2	1N914	Fast-switching diode, DO-35	
D3	1N914	Fast-switching diode, DO-35	
D4	1N914	Fast-switching diode, DO-35	
D5	1N914	Fast-switching diode, DO-35	
D6	LED	LED, 3mm, red diffused	
D7	LED	LED, 3mm, red diffused	
D8	1N914	Fast-switching diode, DO-35	
D9	1N914	Fast-switching diode, DO-35	
D10	1N914	Fast-switching diode, DO-35	
D11	1N914	Fast-switching diode, DO-35	
D12	1N914	Fast-switching diode, DO-35	
D13	1N914	Fast-switching diode, DO-35	
Q1	2N5457	JFET, N-channel, TO-92	Part of the optional Morning Glory gain stage. (see build notes)
IC1	TL072	Operational amplifier, DIP8	
PRES	50k trimmer	Trimmer, 10%, 1/4"	
HARD	SPDT	Toggle switch, SPDT, on-off-on	Hard clipping (low, high or none)
SOFT	SPDT	Toggle switch, SPDT, on-off-on	Soft clipping (low, high or none)
DRIVE	100kB	16mm right-angle PCB mount pot	Linear taper.
TONE	25kB	16mm right-angle PCB mount pot	Linear taper.
VOL	100kA	16mm right-angle PCB mount pot	Audio (log) taper.
IN	1/4" stereo	1/4" phone jack, closed frame	Switchcraft 112BX or equivalent.
OUT	1/4" mono	1/4" phone jack, closed frame	Switchcraft 111X or equivalent.
DC	2.1mm	DC jack, 2.1mm panel mount	Mouser 163-4302-E or equivalent.
BATT	Battery snap	9V battery snap	Optional. Use the soft plastic type—the hard-shell type will not fit.
FSW	3PDT	Stomp switch, 3PDT	
ENC	125B	Enclosure, die-cast aluminum	Can also use a Hammond 1590N1.

## BUILD NOTES

---

### Morning Glory Gain Stage

The JHS Morning Glory adds another gain stage to the end of the circuit for more available output volume. You can choose to build the pedal with this gain stage or without.

To build with the gain stage, **omit C8** and include **RX1-6, CX2-4** and **Q1**.

To build without the gain stage, **include C8** and omit **RX1-6, CX2-4** and **Q1**.

### King of Tone

The Analogman King of Tone is two Bluesbreakers in one box. All of the modifications from the King of Tone are available as part of this project (soft clipping, hard clipping, and Presence control).

If you use a 1790NS enclosure you could fit two of these side by side. Information on this will be provided for this at a later date, but as of right now it is outside the scope of the documentation.

# SCHEMATIC

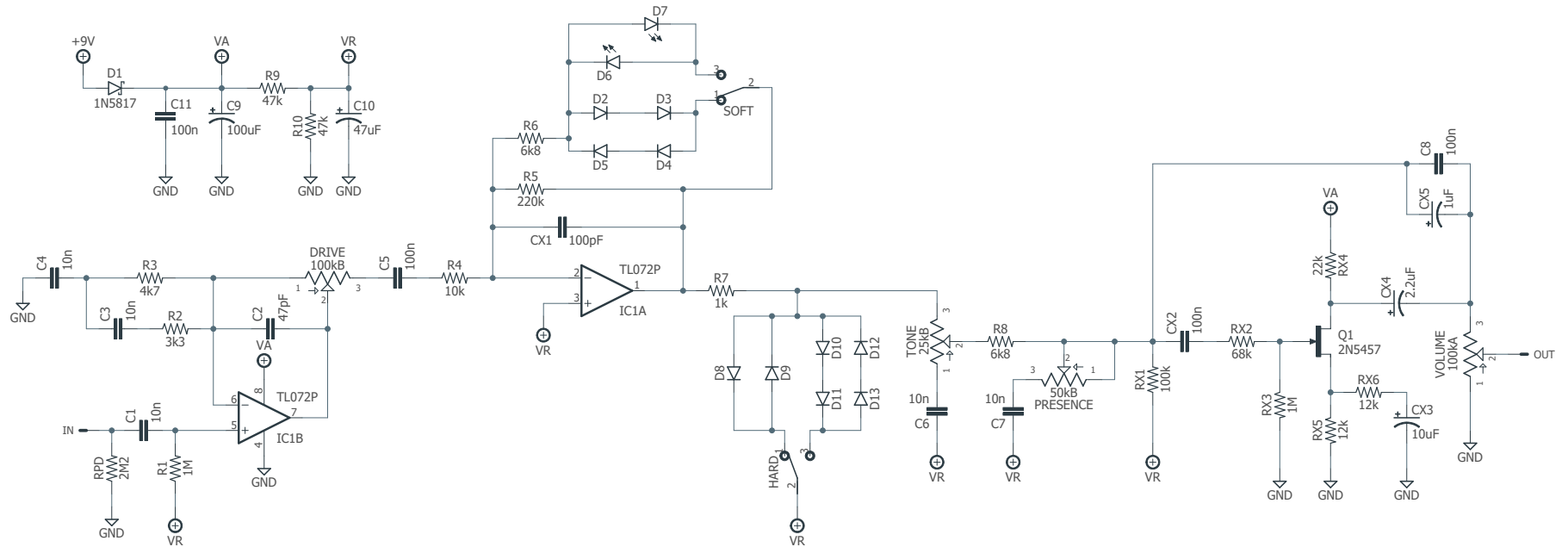

# DRILL TEMPLATE

Cut out this drill template, fold the edges and tape it to the enclosure. Before drilling, it's recommended to first use a center punch for each of the holes to help guide the drill bit.

Ensure that this template is printed at 100% or "Actual Size". You can double-check this by measuring the scale on the printed page.

**Top jack layout** assumes the use of closed-frame jacks like the [Switchcraft 111X](#). If you'd rather use open-frame jacks, please refer to the Open-Frame Jack Drill Template for the top side.

**LED hole drill size** assumes the use of a [5mm LED bezel](#), available from several parts suppliers. Adjust size accordingly if using something different, such as a 3mm bezel, a plastic bezel, or just a plain LED.

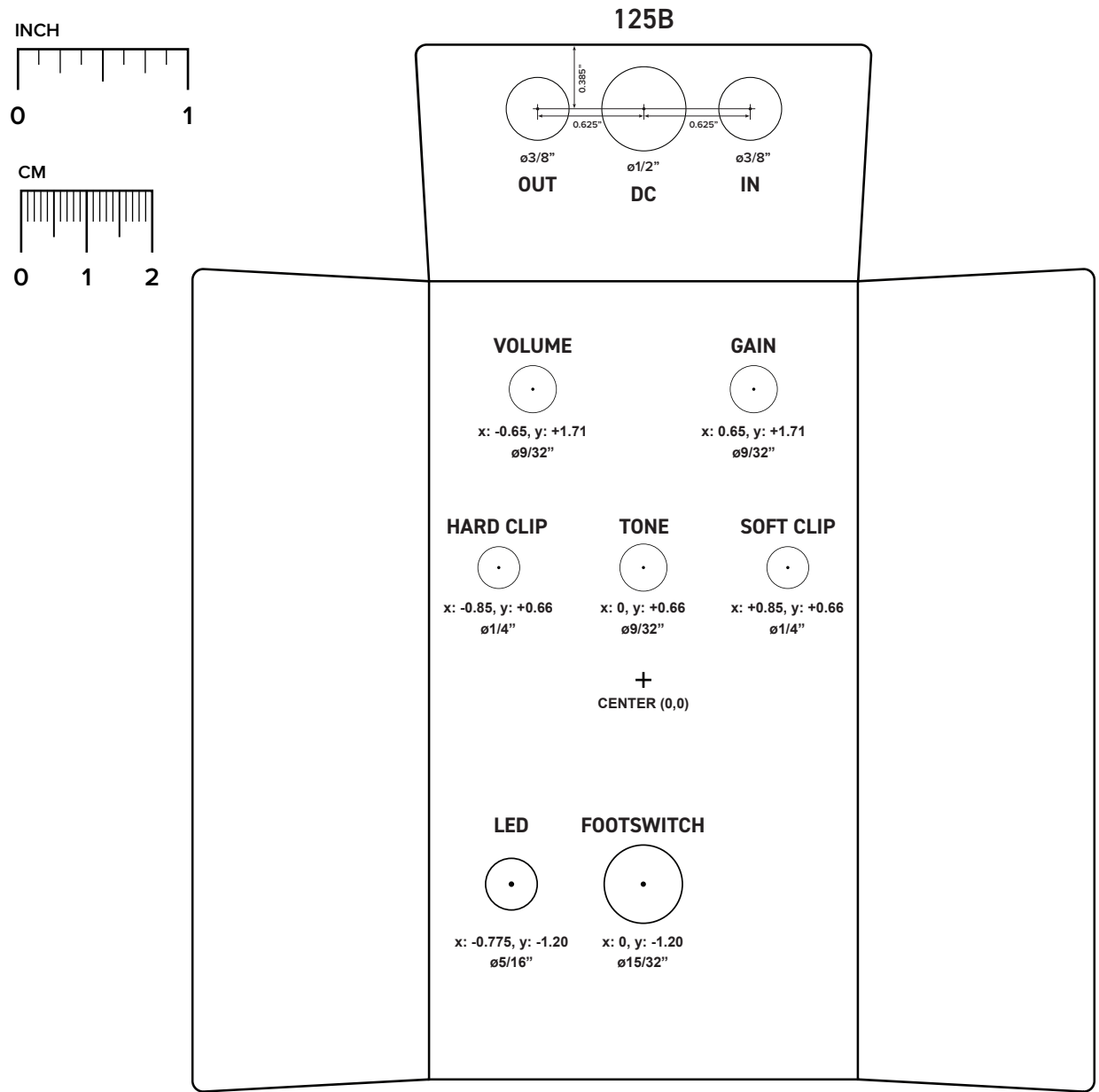

# ENCLOSURE LAYOUT

---

Enclosure is shown without jacks. See next page for jack layout and wiring.

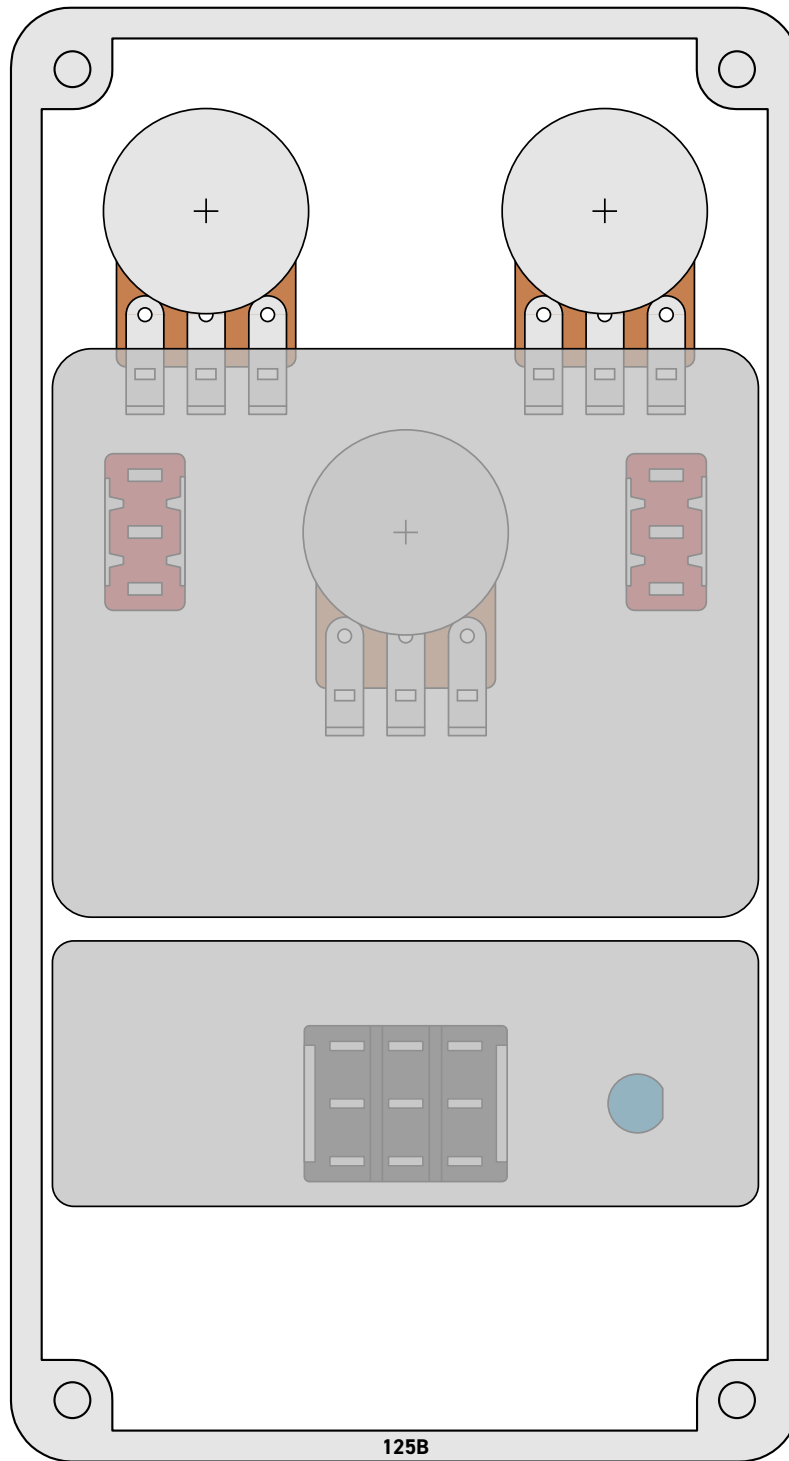



# WIRING DIAGRAM

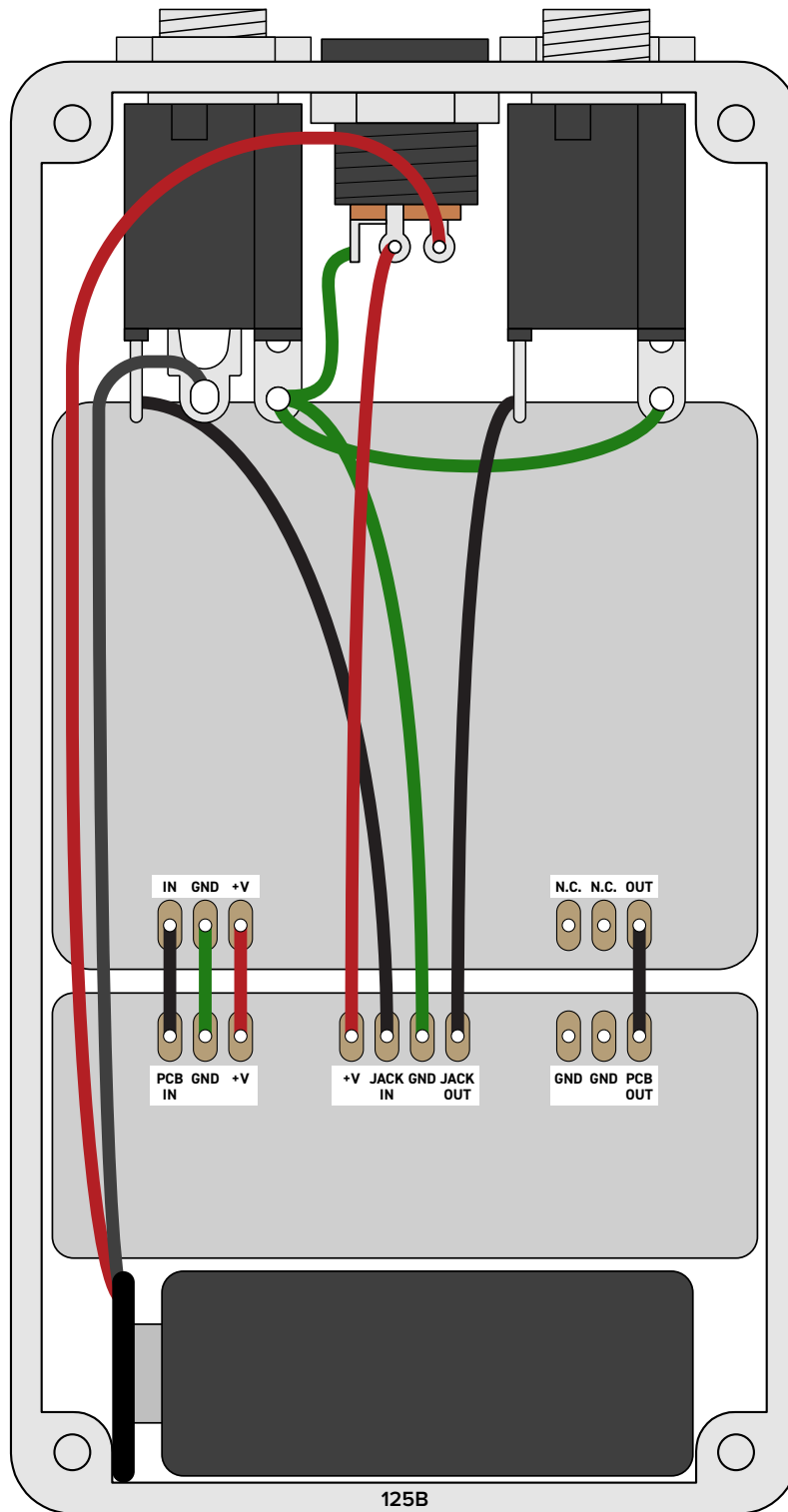

*Shown with optional 9V battery. If battery is omitted, both jacks can be mono rather than one being stereo.  
Leave the far-right lug of the DC jack unconnected.*

## LICENSE & USAGE

---

**No direct support is offered for these projects beyond the provided documentation.** It's assumed that you have at least some experience building pedals before starting one of these. Replacements and refunds cannot be offered unless it can be shown that the circuit or documentation are in error.

**All of these circuits have been tested in good faith in their base configurations.** However, not all the modifications or variations have necessarily been tested. These are offered only as suggestions based on the experience and opinions of others.

**Projects may be used for commercial endeavors in any quantity** unless specifically noted. No attribution is necessary, though a link back is always greatly appreciated. The only usage restrictions are that **(1) you cannot resell the PCB as part of a kit without prior arrangement, and (2) you cannot "goop" the circuit, scratch off the screenprint, or otherwise obfuscate the circuit to disguise its source.** (In other words: you don't have to go out of your way to advertise the fact that you use these PCBs, but please don't go out of your way to hide it. The guitar effects industry needs more transparency, not less!)

## DOCUMENT REVISIONS

---

### 1.1.0 (2020-05-18)

- Changed value of C10 for consistency.
- Slight layout change, relocating D1 to footswitch board.
- Added C11 MLCC capacitor to footswitch board.

### 1.0.1 (2018-08-14)

Corrected parts list to specify LEDs for D6 and D7. Minor formatting adjustments.

### 1.0.0 (2018-07-04)

Initial release.