

PROJECT NAME

ASTERIA MK. II



BASED ON

Catalinbread® Formula No. 5 (V2)

BUILD DIFFICULTY

■■■■■ Easy

EFFECT TYPE

Overdrive / Amp Emulation

DOCUMENT VERSION

1.0.0 (2020-11-27)

PROJECT SUMMARY

An adaptation of the Fender® Deluxe 5E3 amplifier from 1955, a classic low-wattage amplifier noted for its harmonically-rich breakup that can be achieved at low volumes.

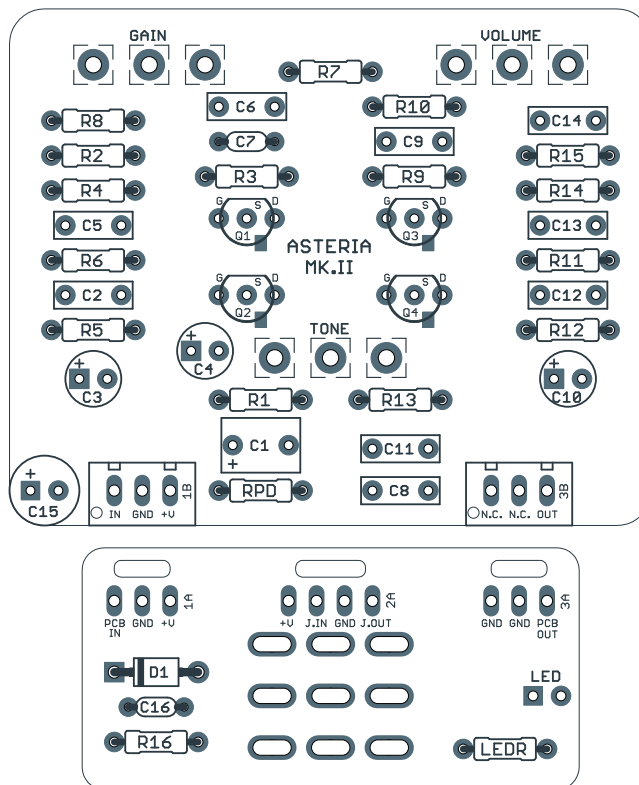

Actual size is 2.3" x 1.86" (main board) and 1.78" x 0.87" (bypass board).

IMPORTANT NOTE

This documentation is for the **Mk. II** version of the project. There are also [Mk. I](#) and [Mk. III](#) versions, based on the Formula No. 5 V1 and the Formula 55. While the names is similar, the circuit and part numbering are different. Please be sure your PCB is labeled "Asteria Mk. II" before proceeding with this build document.

TABLE OF CONTENTS

1	Project Overview	7	Drill Template
2	Introduction & Usage	8	Enclosure Layout
3-4	Parts List	9	Wiring Diagram
5	Build Notes	10	Licensing
6	Schematic	10	Document Revisions

INTRODUCTION

The Asteria Preamp Drive Mk. II is an adaptation of the second version of the Catalinbread Formula No. 5, based on the Fender 5E3 Tweed Deluxe amplifiers from the 1950s. This version of the Formula No. 5 was originally released in 2011 and was traced by Aion FX in 2020.

The Formula No. 5 replicates the quirks of the original Deluxe amp, including a tone control whose effect diminishes as the gain is turned up, with almost no change across the sweep at maximum drive.

Like several other Catalinbread pedals, this circuit blurs the line between a preamp and an overdrive. Like a true preamplifier, it's very reactive to what comes before it, so it's best placed after other drive pedals but before modulation. However, it also generates more than enough drive on its own and can be used as a standalone overdrive pedal just like any other.

The two versions of the Formula No. 5 are similar, but still different enough that we decided to release them as separate projects (the [Asteria Mk. I](#) replicates the original version). The Formula 55 is a full redesign of the circuit from 2017, and it's also available from Aion FX as the [Asteria Mk. III](#).

The Formula No. 5 used 2N5457 JFETs, which are no longer available in through-hole format. Extra pads have been provided if you want to use surface-mount JFETs (part number MMBF5457), which are still in production and perform identically to those used in Catalinbread pedals. Aion FX also offers [pre-soldered MMBF5457s on adapter boards](#) if you find surface-mount parts intimidating. See build notes for more details.

The Asteria Mk. II is compatible with the [18V Voltage Doubler / Bypass module](#) if you want to run the circuit at 18V without an external adapter. The higher voltage provides increased volume and clarity.

USAGE

The Asteria Mk. II has the following controls:

- **Gain** controls the amount of gain in the first amplifier stage.
- **Tone** is a treble-cut control. Its function changes with the gain control position, and has no effect with the gain all the way up.
- **Volume** is the overall output level.

PARTS LIST

This parts list is also available in a spreadsheet format which can be imported directly into Mouser for easy parts ordering. Mouser doesn't carry all the parts (most notably potentiometers) so the second tab lists all the non-Mouser parts as well as sources for each.

[View parts list spreadsheet](#) →

PART	VALUE	TYPE	NOTES
R1	62k	Metal film resistor, 1/4W	
R2	1M	Metal film resistor, 1/4W	
R3	1M	Metal film resistor, 1/4W	
R4	2k2	Metal film resistor, 1/4W	
R5	1M	Metal film resistor, 1/4W	
R6	1M	Metal film resistor, 1/4W	
R7	10k	Metal film resistor, 1/4W	
R8	10k	Metal film resistor, 1/4W	
R9	100k	Metal film resistor, 1/4W	
R10	1M	Metal film resistor, 1/4W	
R11	2k2	Metal film resistor, 1/4W	
R12	1M	Metal film resistor, 1/4W	
R13	1M	Metal film resistor, 1/4W	
R14	10k	Metal film resistor, 1/4W	
R15	4k7	Metal film resistor, 1/4W	
R16	100R	Metal film resistor, 1/4W	
RPD	1M	Metal film resistor, 1/4W	
LEDR	4k7	Film capacitor, 7.2 x 5mm	LED current-limiting resistor. Adjust value to change LED brightness.
C1	2.2uF	Film capacitor, 7.2 x 5mm	Can also substitute electrolytic (polarity marked on PCB)
C2	100n	Film capacitor, 7.2 x 2.5mm	
C3	22uF	Electrolytic capacitor, 5mm	
C4	4.7uF	Electrolytic capacitor, 4mm	
C5	1n	Film capacitor, 7.2 x 2.5mm	
C6	100n	Film capacitor, 7.2 x 2.5mm	
C7	470pF	MLCC capacitor, NP0/C0G	
C8	4n7	Film capacitor, 7.2 x 2.5mm	
C9	47n	Film capacitor, 7.2 x 2.5mm	
C10	10uF	Electrolytic capacitor, 5mm	
C11	100n	Film capacitor, 7.2 x 2.5mm	
C12	22n	Film capacitor, 7.2 x 2.5mm	

PARTS LIST, CONT.

PART	VALUE	TYPE	NOTES
C13	1n	Film capacitor, 7.2 x 2.5mm	
C14	1n	Film capacitor, 7.2 x 2.5mm	
C15	100uF	Electrolytic capacitor, 6.3mm	Power supply filter capacitor.
C16	100n	MLCC capacitor, X7R	Power supply filter capacitor.
D1	1N5817	Schottky diode, DO-41	
Q1	MMBF5457	JFET, N-channel, SOT-23	Substitute for 2N5457 (TO-92). See build notes.
Q2	MMBF5457	JFET, N-channel, SOT-23	Substitute for 2N5457 (TO-92). See build notes.
Q3	MMBF5457	JFET, N-channel, SOT-23	Substitute for 2N5457 (TO-92). See build notes.
Q4	MMBF5457	JFET, N-channel, SOT-23	Substitute for 2N5457 (TO-92). See build notes.
GAIN	1MA	16mm right-angle PCB mount pot	
TONE	1MB	16mm right-angle PCB mount pot	
VOL.	500kA	16mm right-angle PCB mount pot	
IN	1/4" stereo	1/4" phone jack, closed frame	Switchcraft 112BX or equivalent.
OUT	1/4" mono	1/4" phone jack, closed frame	Switchcraft 111X or equivalent.
DC	2.1mm	DC jack, 2.1mm panel mount	Mouser 163-4302-E or equivalent.
FSW	3PDT	Stomp switch, 3PDT	
ENC	125B	Enclosure, die-cast aluminum	Can also use a Hammond 1590N1.

BUILD NOTES

Using SMD JFETs

The 2N5457 JFET is no longer available in through-hole format. This PCB uses a hybrid through-hole/SMD outline for each JFET. An extra “G” (gate) pad is included to accommodate surface-mount devices without the need for adapters.

SMD JFETs should be oriented as follows:

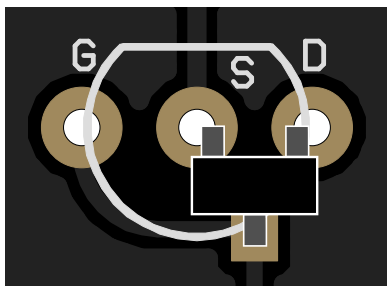

All surface-mount JFETs use the same pinout, so this configuration will fit any type that we’re aware of. However, always check the datasheet if you’re uncertain—they’re difficult to desolder if you make a mistake.

Using through-hole adapters

If you’re not confident in your ability to work with surface-mount parts, Aion FX offers [2N5457 \(MMBF5457\) JFETs](#) that come pre-soldered to adapters for use in through-hole designs. These are from the same manufacturer as the ones used in the original Catalinbread pedals and will perform identically.

Using old-stock JFETs

JFETs are an odd category of component because their manufacturing process is highly inconsistent. The datasheet for a given part number will usually show an enormous range for crucial specifications such as $V_{GS(off)}$ and I_{DSS} .

However, in practice, parts from the same manufacturer are usually much tighter in specification. So while the 2N5457 has a $V_{GS(off)}$ range of -0.5V to -6.0V, devices from ON Semiconductor (Fairchild) will usually be between -1V and -2V. This is the brand of JFETs used by Catalinbread in this pedal.

This means that the part number itself is not usually enough to go by if you’re trying to replicate a circuit that uses JFETs in certain types of applications, notably when they’re used for overdrive.

So while the 2N5457 is sometimes available from manufacturers such as Central Semiconductor or InterFET, the ones we’ve tested have been very far outside the ON Semi range and will perform very differently in this circuit. Therefore, **it is not recommended to use 5457 JFETs from any manufacturer except ON Semiconductor**—although it makes no difference whether it’s an old-stock through-hole type or the current-production MMBF5457 SMD type.

Conversely, if you find a different type of JFET that measures in the -1V to -2V range for $V_{GS(off)}$, it should work just as well as the 2N5457.

SCHEMATIC

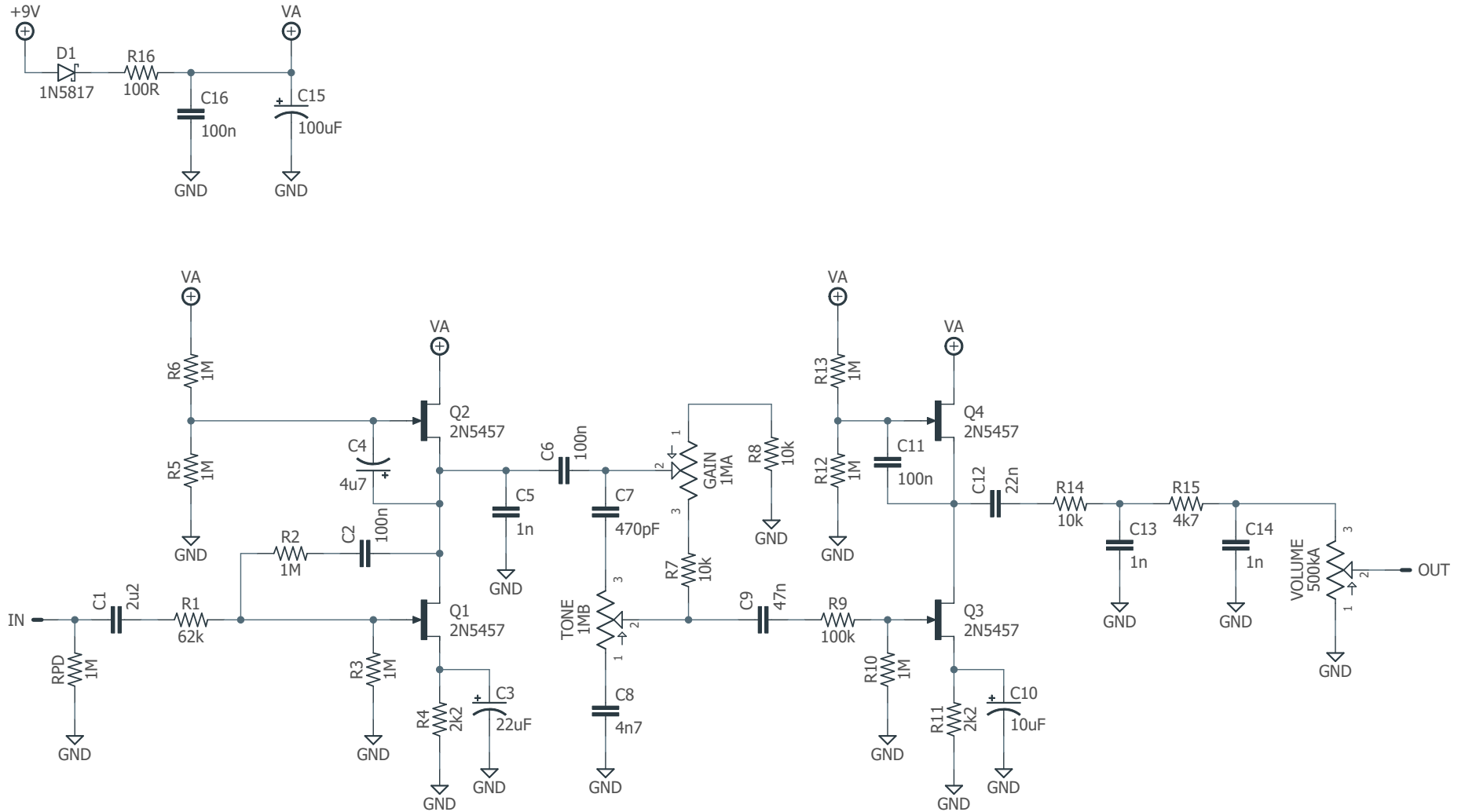

DRILL TEMPLATE

Cut out this drill template, fold the edges and tape it to the enclosure. Before drilling, it's recommended to first use a center punch for each of the holes to help guide the drill bit.

Ensure that this template is printed at 100% or "Actual Size". You can double-check this by measuring the scale on the printed page.

Top jack layout assumes the use of closed-frame jacks like the [Switchcraft 111X](#). If you'd rather use open-frame jacks, please refer to the [Open-Frame Jack Drill Template](#) for the top side.

LED hole drill size assumes the use of a [5mm LED bezel](#), available from several parts suppliers. Adjust size accordingly if using something different, such as a 3mm bezel, a plastic bezel, or just a plain LED.

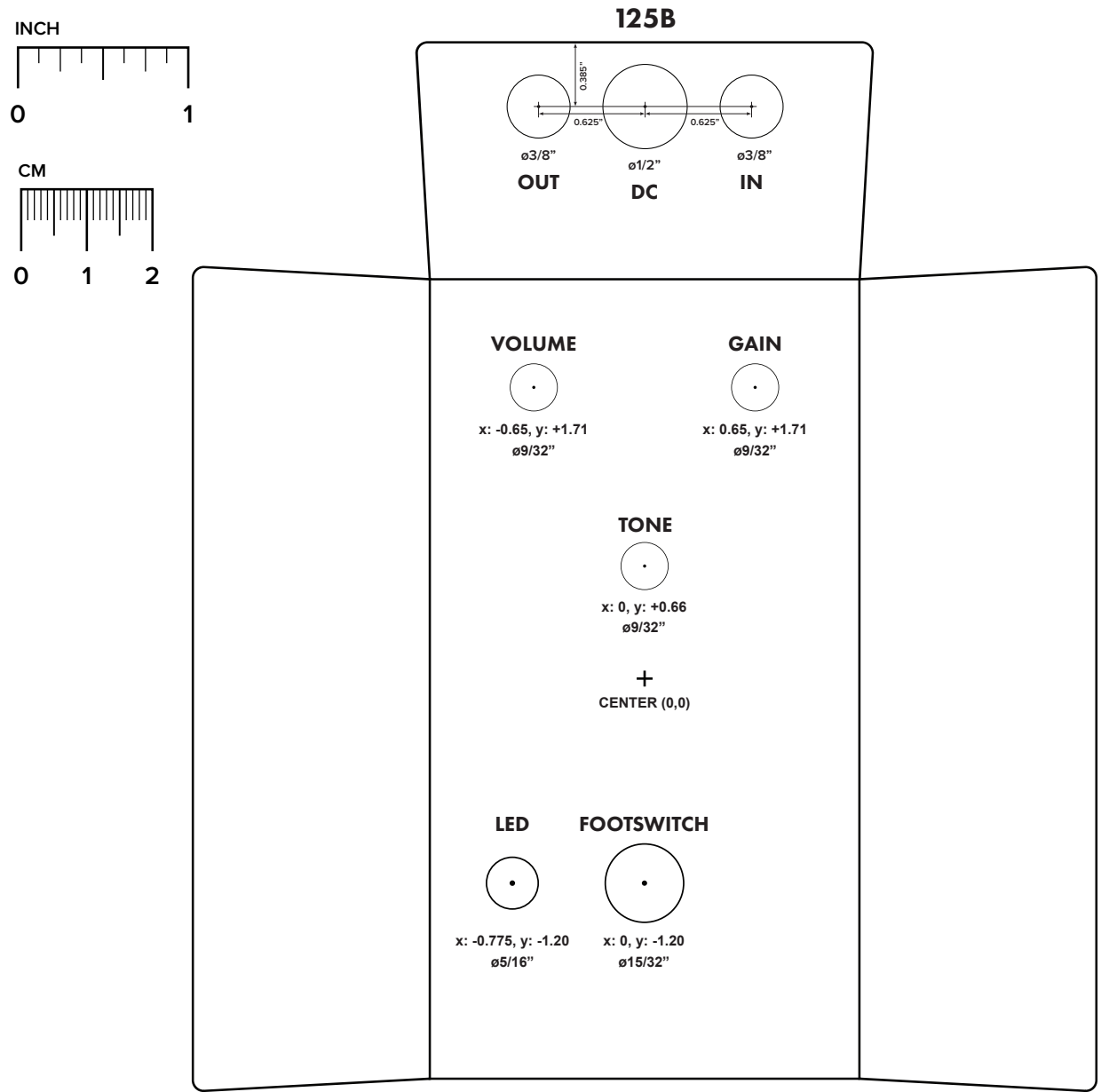

ENCLOSURE LAYOUT

Enclosure is shown without jacks. See next page for jack layout and wiring.

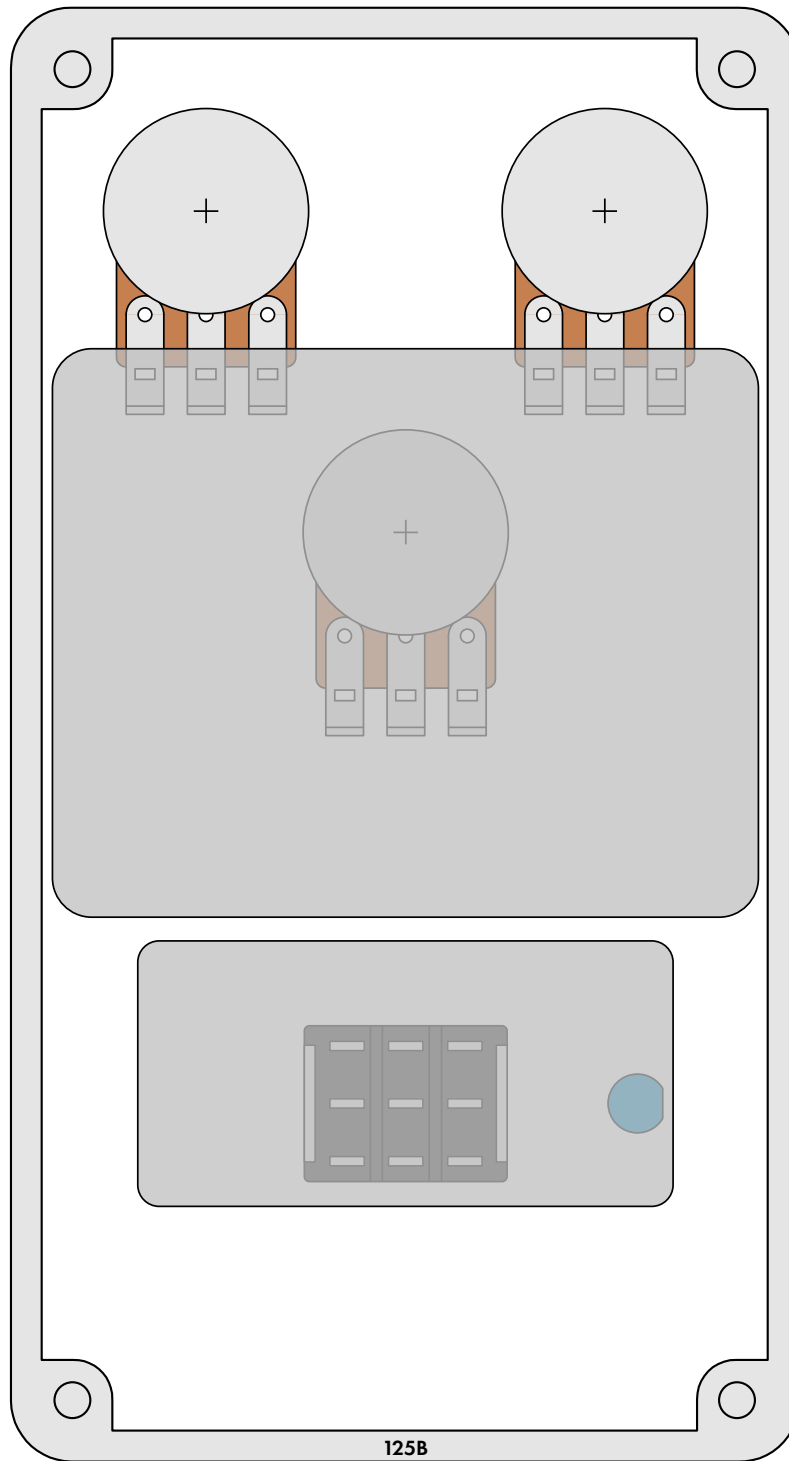

WIRING DIAGRAM

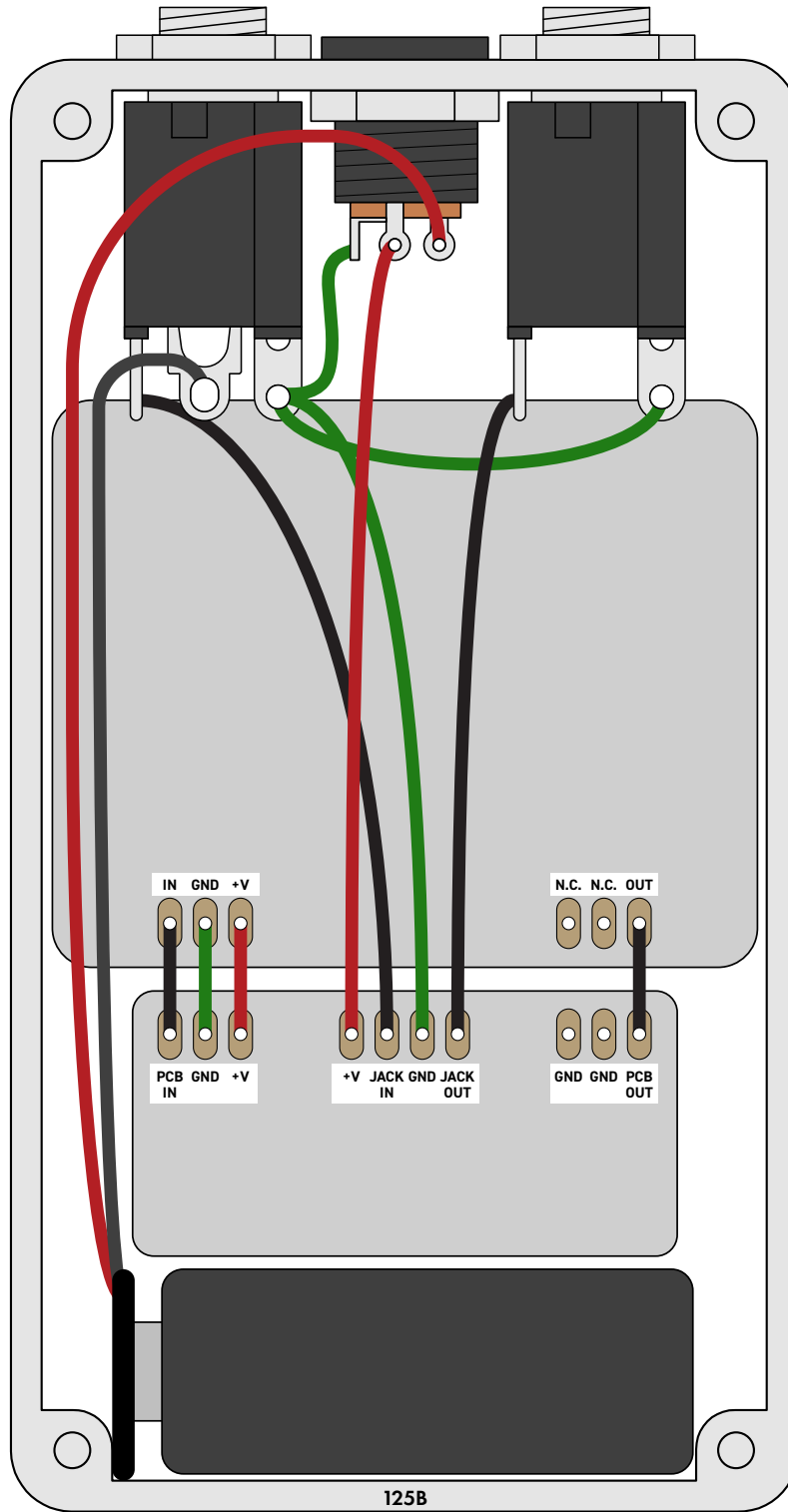

LICENSE & USAGE

No direct support is offered for these projects beyond the provided documentation. It's assumed that you have at least some experience building pedals before starting one of these. Replacements and refunds cannot be offered unless it can be shown that the circuit or documentation are in error.

All of these circuits have been tested in good faith in their base configurations. However, not all the modifications or variations have necessarily been tested. These are offered only as suggestions based on the experience and opinions of others.

Projects may be used for commercial endeavors in any quantity unless specifically noted. No attribution is necessary, though a link back is always greatly appreciated. The only usage restrictions are that **(1) you cannot resell the PCB as part of a kit without prior arrangement, and (2) you cannot “goop” the circuit, scratch off the screenprint, or otherwise obfuscate the circuit to disguise its source.** (In other words: you don't have to go out of your way to advertise the fact that you use these PCBs, but please don't go out of your way to hide it. The guitar effects industry needs more transparency, not less!)

DOCUMENT REVISIONS

1.0.0 (2020-11-27)

Initial release.