

PROJECT NAME

ARGENT

BASED ON

BOSS® FZ-3 Fuzz

EFFECT TYPE

Silicon fuzz

BUILD DIFFICULTY

■■■■■ Easy

DOCUMENT VERSION

1.0.0 (2021-11-26)



PROJECT SUMMARY

An all-transistor silicon fuzz with similarities to the Tone Bender, Fuzz Face and Big Muff.

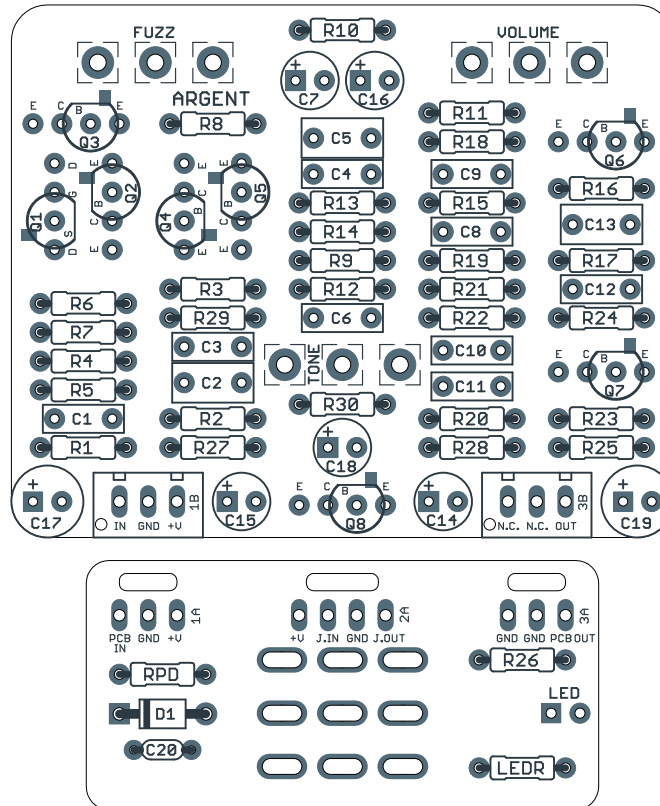

Actual size is 2.3" x 1.86" (main board) and 1.78" x 0.87" (bypass board).

TABLE OF CONTENTS

1	Project Overview	8	Drill Template
2	Introduction & Usage	9	Enclosure Layout
3-5	Parts List	10	Wiring Diagram
6	Build Notes	11	Licensing
7	Schematic	11	Document Revisions

INTRODUCTION

The Argent Silicon Fuzz is based on the BOSS® FZ-3 Fuzz, originally released in 1997. Although it was discontinued after only a couple of years, today they routinely sell for USD\$250 or more. Notable users include John Frusciante (Red Hot Chili Peppers) and Billy Corgan (Smashing Pumpkins).

While it was marketed as a successor to the FZ-2 Hyper Fuzz, in reality the two circuits share nothing whatsoever in common, either in tone or in the underlying circuitry. The FZ-3 is loosely based on the Fuzz Face and Tone Bender circuits, while the FZ-2 is derived from the Superfuzz with an input boost and tone stack added.

The FZ-3 has been traced on two prior occasions by the DIY community, but both schematics have several incorrect values and would not result in a workable fuzz effect. We traced an original unit ourselves in 2021 to come up with a definitive schematic, and as a result, the Argent is the first accurate clone of the FZ-3.

Aside from the conversion to true bypass, the Argent is the same as the original unit with no modifications or substitutions. And while the input JFET's type is not terribly important, Aion FX does offer the [2SK209-GR](#) (the SMD version of 2SK184-GR) pre-soldered to through-hole adapter PCBs.

USAGE

The Argent has three controls:

- **Fuzz** increases the gain of the middle transistor gain stage, a sub-circuit that resembles a silicon Fuzz Face.
- **Tone** is a Big Muff-style balance control with a bass emphasis on one side and a treble emphasis on the other, with the center position being roughly flat.
- **Volume** sets the overall output of the effect signal.

PARTS LIST

This parts list is also available in a spreadsheet format which can be imported directly into Mouser for easy parts ordering. Mouser doesn't carry all the parts—notably potentiometers—so the second tab lists all the non-Mouser parts as well as sources for each.

[View parts list spreadsheet](#) →

PART	VALUE	TYPE	NOTES
R1	10k	Metal film resistor, 1/4W	
R2	1M	Metal film resistor, 1/4W	
R3	10k	Metal film resistor, 1/4W	
R4	12k	Metal film resistor, 1/4W	
R5	47k	Metal film resistor, 1/4W	
R6	220R	Metal film resistor, 1/4W	
R7	10k	Metal film resistor, 1/4W	
R8	33k	Metal film resistor, 1/4W	
R9	2k2	Metal film resistor, 1/4W	
R10	15k	Metal film resistor, 1/4W	
R11	6k8	Metal film resistor, 1/4W	
R12	100k	Metal film resistor, 1/4W	
R13	22k	Metal film resistor, 1/4W	
R14	3k3	Metal film resistor, 1/4W	
R15	3k3	Metal film resistor, 1/4W	
R16	150k	Metal film resistor, 1/4W	
R17	330k	Metal film resistor, 1/4W	
R18	10k	Metal film resistor, 1/4W	
R19	10k	Metal film resistor, 1/4W	
R20	47k	Metal film resistor, 1/4W	
R21	47k	Metal film resistor, 1/4W	
R22	47k	Metal film resistor, 1/4W	
R23	100k	Metal film resistor, 1/4W	
R24	10k	Metal film resistor, 1/4W	
R25	100k	Metal film resistor, 1/4W	
R26	1k	Metal film resistor, 1/4W	
R27	22k	Metal film resistor, 1/4W	
R28	22k	Metal film resistor, 1/4W	
R29	220R	Metal film resistor, 1/4W	
R30	2k2	Metal film resistor, 1/4W	
RPD	2M2	Metal film resistor, 1/4W	Input pulldown resistor. Can be as low as 1M.
LEDR	4k7	Metal film resistor, 1/4W	LED current-limiting resistor. Adjust value to change LED brightness.

PARTS LIST, CONT.

PART	VALUE	TYPE	NOTES
C1	47n	Film capacitor, 7.2 x 2.5mm	
C2	220n	Film capacitor, 7.2 x 2.5mm	Original uses 1uF + 330n for a series value of 248n.
C3	27n	Film capacitor, 7.2 x 2.5mm	Paralleled with C2 for 247n total.
C4	10n	Film capacitor, 7.2 x 2.5mm	
C5	1uF	Film capacitor, 7.2 x 3.5mm	
C6	1n	Film capacitor, 7.2 x 2.5mm	
C7	10uF	Electrolytic capacitor, 5mm	
C8	18n	Film capacitor, 7.2 x 2.5mm	
C9	8n2	Film capacitor, 7.2 x 2.5mm	
C10	47n	Film capacitor, 7.2 x 2.5mm	
C11	10n	Film capacitor, 7.2 x 2.5mm	
C12	10n	Film capacitor, 7.2 x 2.5mm	
C13	1uF	Film capacitor, 7.2 x 3.5mm	
C14	10uF	Electrolytic capacitor, 5mm	
C15	47uF	Electrolytic capacitor, 5mm	Reference voltage filter capacitor.
C16	47uF	Electrolytic capacitor, 5mm	Power supply filter capacitor.
C17	100uF	Electrolytic capacitor, 6.3mm	Power supply filter capacitor.
C18	47uF	Electrolytic capacitor, 5mm	Power supply filter capacitor.
C19	100uF	Electrolytic capacitor, 6.3mm	Power supply filter capacitor.
C20	100n	MLCC capacitor, X7R	Power supply filter capacitor.
D1	1N5817	511-1N5817	
Q1	2SK209-GR	757-2SK209GRTE85LF	Original uses 2SK184-GR. 2SK209-GR is the SMD equivalent.
Q2	2N5088	610-2N5088	Original uses 2SC2458-LG. 2N5088 is equivalent.
Q3	2N5088	610-2N5088	Original uses 2SC2458-LG. 2N5088 is equivalent.
Q4	2N5088	610-2N5088	Original uses 2SC2458-LG. 2N5088 is equivalent.
Q5	2N5088	610-2N5088	Original uses 2SC2458-LG. 2N5088 is equivalent.
Q6	2N5088	610-2N5088	Original uses 2SC2458-LG. 2N5088 is equivalent.
Q7	2N5088	610-2N5088	Original uses 2SC2458-GR. 2N5088 is equivalent.
Q8	2N5088	610-2N5088	Original uses 2SC2458-GR. 2N5088 is equivalent.

PARTS LIST, CONT.

PART	VALUE	TYPE	NOTES
FUZZ	1kC	16mm right-angle PCB mount pot	
TONE	100kW	16mm right-angle PCB mount pot	Can substitute 100kB instead if you can't find W-taper.
VOLUME	100kA	16mm right-angle PCB mount pot	
LED	5mm	LED, 5mm, red diffused	
IN	1/4" stereo	1/4" phone jack, closed frame	Switchcraft 111X or equivalent.
OUT	1/4" mono	1/4" phone jack, closed frame	Switchcraft 111X or equivalent.
DC	2.1mm	DC jack, 2.1mm panel mount	Mouser 163-4302-E or equivalent.
FSW	3PDT	Stomp switch, 3PDT	
ENC	125B	Enclosure, die-cast aluminum	Can also use a Hammond 1590N1.

BUILD NOTES

Using SMD JFETs

The 2SK184-GR JFET is no longer available in through-hole format. This PCB uses a hybrid through-hole/SMD outline for each JFET. An extra “G” (gate) pad is included to accommodate surface-mount devices without the need for adapters.

SMD JFETs should be oriented as follows:

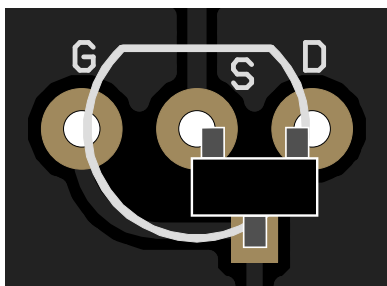

All surface-mount JFETs use the same pinout, so this configuration will fit any type that we’re aware of. However, always check the datasheet if you’re uncertain—they’re difficult to desolder.

Using through-hole adapters

If you’re not confident in your ability to work with SMD parts, Aion FX offers [2SK209-GR JFETs](#) (the SMD version of 2SK184-GR) that come pre-soldered to adapters for use in through-hole designs. These are from the same manufacturer as the ones used in the original circuit and will perform identically.

Using old-stock transistors

Toshiba has not manufactured through-hole transistors and JFETs in many years, but it’s still possible to find the 2SK184-GR and 2SC2458-GR transistors used in the original. However, be aware that these follow the Japanese pinout conventions, whereas the PCB layout is set up for USA conventions since there are a lot more widely-available substitutes in this format.

For those using original Toshiba through-hole JFETs or BJTs, an extra pad has been added to the left of the transistor outline (drain for JFETs, emitter for BJTs) so that the Japanese pinout can be easily used without needing to twist the legs around. In both cases, the transistor should be rotated 180 degrees from the silkscreen and shifted over one pad, as shown:



C2/C3 values

In the original FZ-3, the JFET switching comes after the input buffer. When the effect is engaged, a 1 μ F and 330nF capacitor are in series, giving an effective value of 248nF. Since this is partway between two standard capacitor values, we added a second capacitor in parallel. This way you can use 220nF + 27nF, which is within 0.5% of the original value.

SCHEMATIC

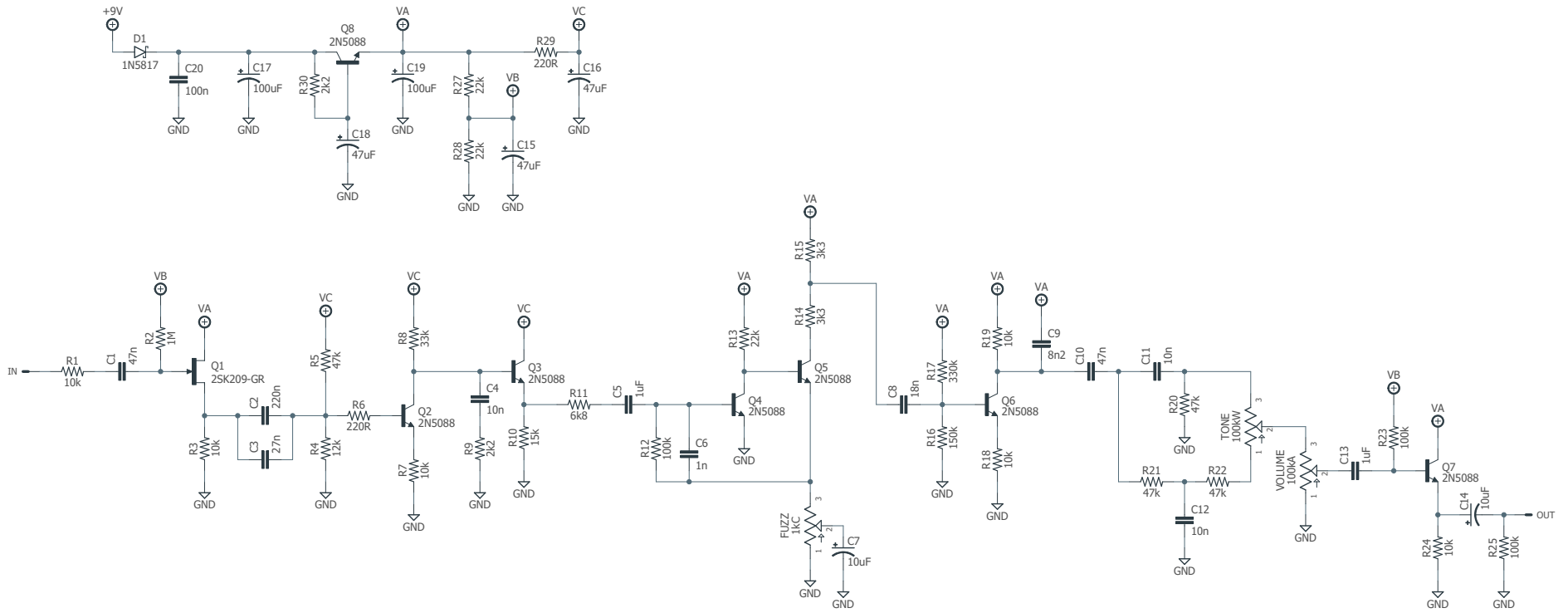

DRILL TEMPLATE

Cut out this drill template, fold the edges and tape it to the enclosure. Before drilling, it's recommended to first use a center punch for each of the holes to help guide the drill bit.

Ensure that this template is printed at 100% or "Actual Size". You can double-check this by measuring the scale on the printed page.

Top jack layout assumes the use of closed-frame jacks like the [Switchcraft 111X](#). If you'd rather use open-frame jacks, please refer to the Open-Frame Jack Drill Template for the top side.

LED hole drill size assumes the use of a [5mm LED bezel](#), available from several parts suppliers. Adjust size accordingly if using something different, such as a 3mm bezel, a plastic bezel, or just a plain LED.

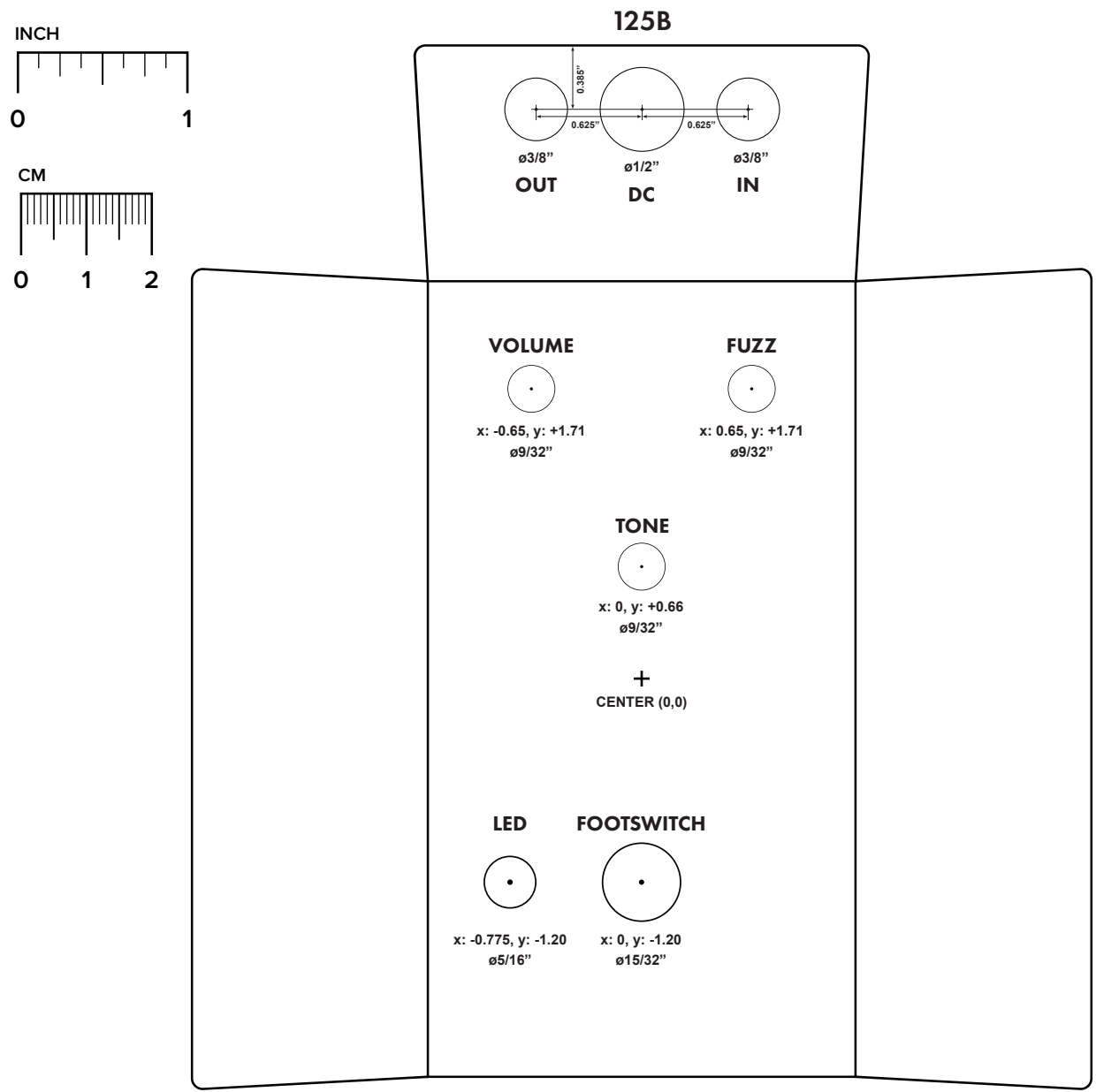

ENCLOSURE LAYOUT

Enclosure is shown without jacks. See next page for jack layout and wiring.

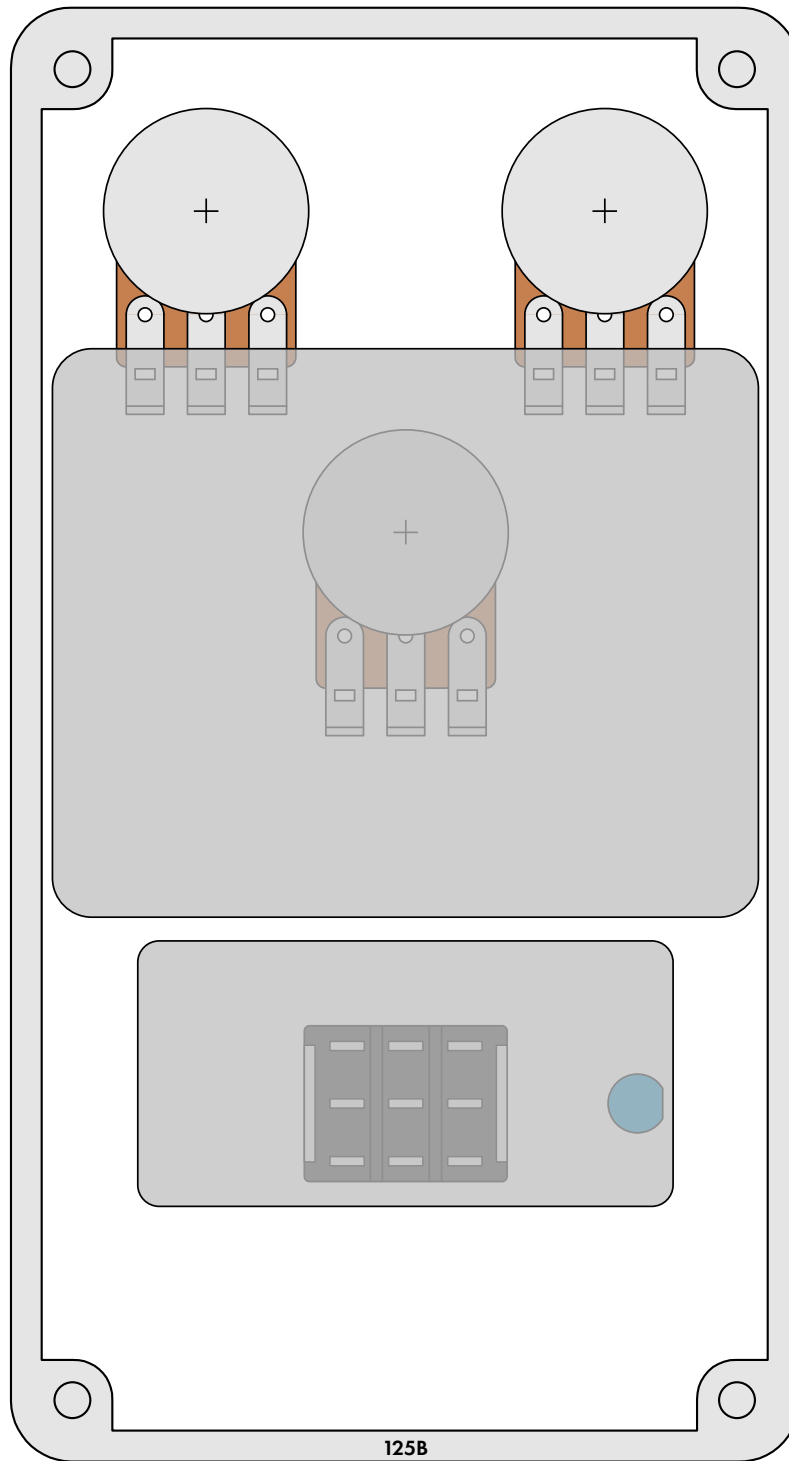

WIRING DIAGRAM

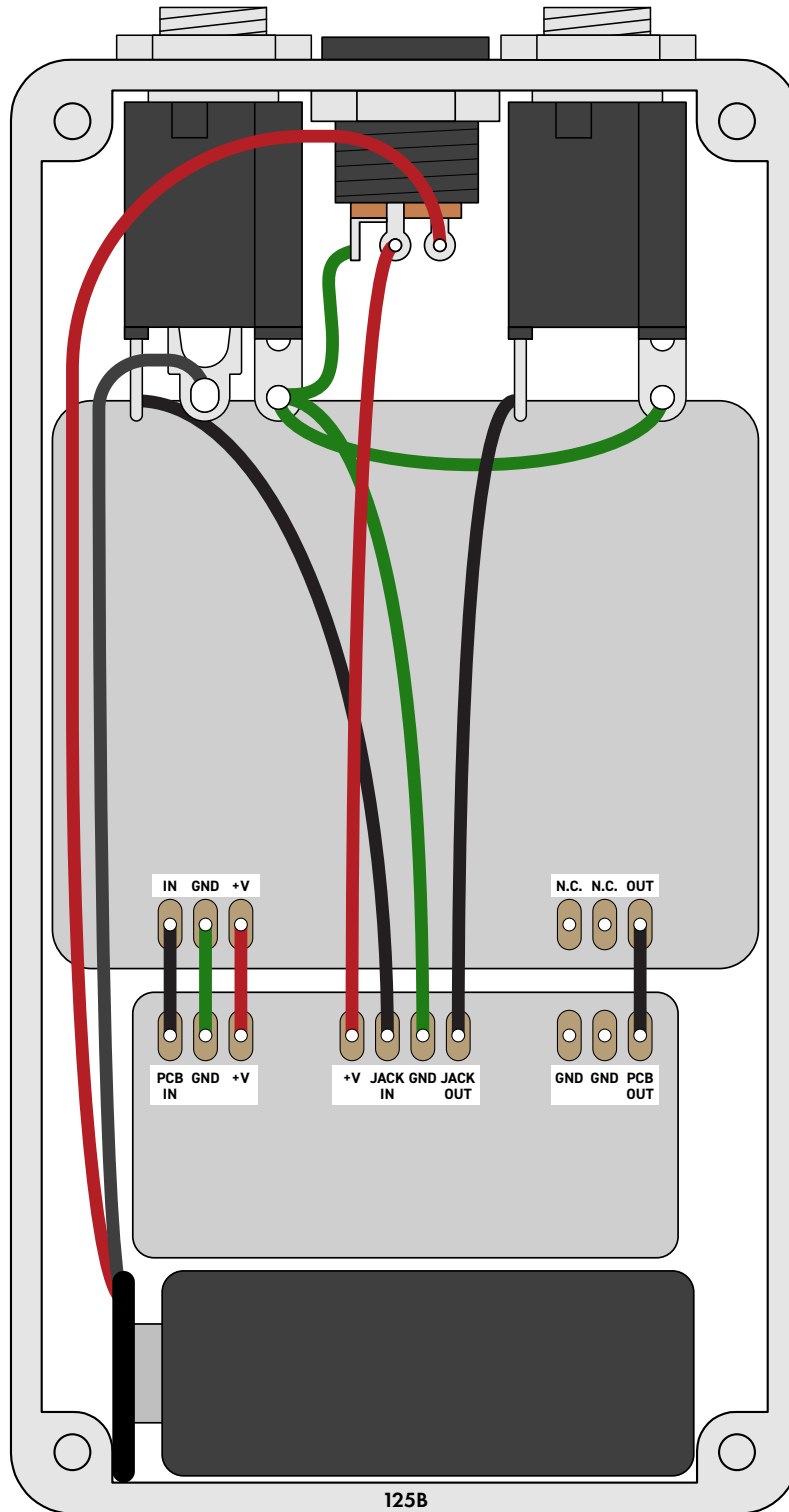

LICENSE & USAGE

No direct support is offered for these projects beyond the provided documentation. It's assumed that you have at least some experience building pedals before starting one of these. Replacements and refunds cannot be offered unless it can be shown that the circuit or documentation are in error.

All of these circuits have been tested in good faith in their base configurations. However, not all the modifications or variations have necessarily been tested. These are offered only as suggestions based on the experience and opinions of others.

Projects may be used for commercial endeavors in any quantity unless specifically noted. No attribution is necessary, though a link back is always greatly appreciated. The only usage restrictions are that **(1) you cannot resell the PCB as part of a kit without prior arrangement, and (2) you cannot "goop" the circuit, scratch off the screenprint, or otherwise obfuscate the circuit to disguise its source.** (In other words: you don't have to go out of your way to advertise the fact that you use these PCBs, but please don't go out of your way to hide it. The guitar effects industry needs more transparency, not less!)

DOCUMENT REVISIONS

1.0.0 (2021-11-26)

Initial release.