

PROJECT NAME

# APHELION



BASED ON

MXR Distortion+ / DOD 250

BUILD DIFFICULTY

■■■■■ Easy

EFFECT TYPE

Distortion/Overdrive

DOCUMENT VERSION

1.0.1 (2020-09-28)

## PROJECT SUMMARY

One of the first drive pedals to use an op-amp, this classic effect was a favorite of Yngwie Malmsteen, Thom Yorke and Randy Rhoads among many more.

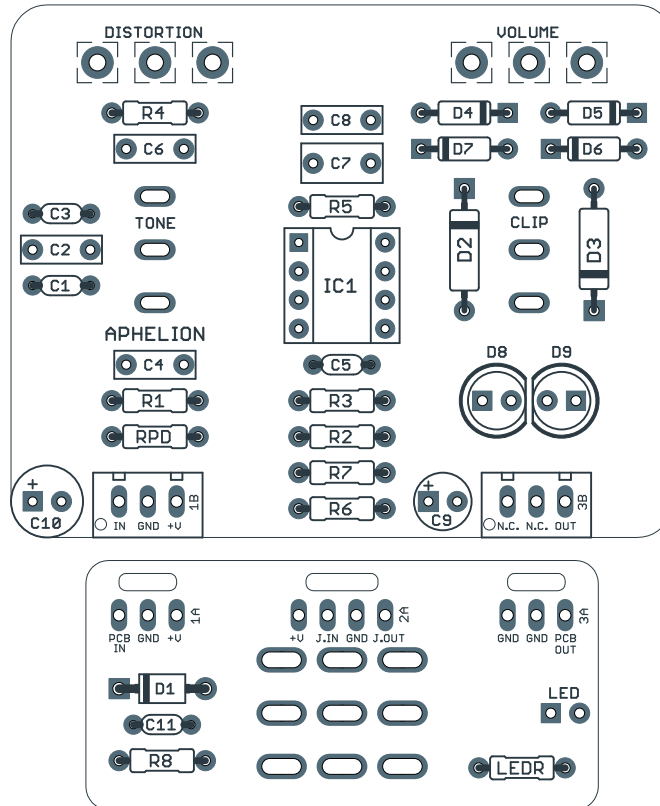

Actual size is 2.3" x 1.86" (main board) and 2.3" x 0.86" (bypass board).

# TABLE OF CONTENTS

---

|     |                      |    |                    |
|-----|----------------------|----|--------------------|
| 1   | Project Overview     | 7  | Drill Template     |
| 2   | Introduction & Usage | 8  | Enclosure Layout   |
| 3-4 | Parts List           | 9  | Wiring Diagram     |
| 5   | Build Notes          | 10 | Licensing          |
| 6   | Schematic            | 10 | Document Revisions |

## INTRODUCTION

---

The Aphelion Vintage Distortion is a clone of the MXR Distortion+, one of the first op-amp-based drive pedals going all the way back to 1973.

This was also one of the first circuits to use hard diode-to-ground clipping, and while it's a fairly simple circuit, it served as an ancestor to many other classic pedals like the Boss DS-1 and Maxon/Ibanez SD-9. It has no tone control, but instead, the gain control also changes the tone as you turn it up. Technically speaking, only the bass frequency is cut, but this has the perceived effect of increasing treble as well.

DOD released their version in a few years later in 1976, which they called the Overdrive Preamp 250 (commonly abbreviated to just the "250"). Both versions are classics in their own right, with the Distortion+ being favored by Randy Rhoads, Jerry Garcia, and Thom Yorke, while the 250 is inseparably associated with Yngwie Malmsteen.

Like the Big Muff, both the Distortion+ and 250 had a lot of circuit tweaks throughout the manufacturing run. Because of this, there's no definitive version of either of them, although some variants were more notable than others.

The Aphelion adds two extra modifications to the classic two-knob circuit: a treble-cut switch that changes out a capacitor at the input, and a diode selector that lets you go between germanium (Distortion+), silicon (250), or LEDs.

The updated 125B version of the Aphelion has been changed slightly from the earlier version. The treble-cut toggle has been revised so that it switches out the low-pass capacitor at the input rather than the one at the output. Also, the "Compression" (input coupling capacitor) toggle has been removed since it had very little impact unless the pedal was first in the chain, and even then it wasn't very useful.

## USAGE

---

The Aphelion has two controls and two toggles:

- **Gain** controls the amount of gain from the op-amp stage that goes into the clipping diodes.
- **Volume** is the output volume of the effect.
- **Treble** toggles between different hi-cut capacitors at the input.
- **Clip** toggles between different sets of clipping diodes.

## PARTS LIST

This parts list is also available in a spreadsheet format which can be imported directly into Mouser for easy parts ordering. Mouser doesn't carry all the parts—notably potentiometers—so the second tab lists all the non-Mouser parts as well as sources for each.

[View parts list spreadsheet](#) →

The values provided below are for the Distortion+ and the '79 Gray 250. Other versions including the YJM308 and Micro Amp can be built, as well as other variations of the 250. See the [Distortion+/250 Versions spreadsheet](#) for parts table and notes.

| PART | VALUE (D+) | VALUE (250)   | TYPE                        | NOTES   |
|------|------------|---------------|-----------------------------|---|
| R1   | 10k        | 10k           | Metal film resistor, 1/4W   |   |
| R2   | 1M         | 470k          | Metal film resistor, 1/4W   |   |
| R3   | 1M         | 1M            | Metal film resistor, 1/4W   |   |
| R4   | 4k7        | 4k7           | Metal film resistor, 1/4W   |   |
| R5   | 10k        | 10k           | Metal film resistor, 1/4W   |   |
| R6   | 1M         | 22k           | Metal film resistor, 1/4W   |   |
| R7   | 1M         | 22k           | Metal film resistor, 1/4W   |   |
| R8   | 100R       | 100R          | Metal film resistor, 1/4W   | Power supply filter resistor.   |
| RPD  | 2M2        | 2M2           | Metal film resistor, 1/4W   | Input pulldown resistor. Can be as low as 1M.                         |
| LEDR | 4k7        | 4k7           | Metal film resistor, 1/4W   | LED current-limiting resistor. Adjust value to change LED brightness. |
| C1   | 47pF       | 47pF          | Film capacitor, 7.2 x 2.5mm | See build notes for tone switch configuration.                        |
| C2   | 1n         | 1n            | Electrolytic capacitor, 5mm | See build notes for tone switch configuration.                        |
| C3   | 2n2        | 2n2           | MLCC capacitor, NP0/COG     | See build notes for tone switch configuration.                        |
| C4   | 10n        | 10n           | Electrolytic capacitor, 5mm |   |
| C5   | 10pF       | 10pF          | Electrolytic capacitor, 5mm | See build notes.  |
| C6   | 47n        | 47n           | Film capacitor, 7.2 x 2.5mm |   |
| C7   | 1uF        | 4.7uF electro | Film capacitor, 7.2 x 2.5mm |   |
| C8   | 1n         | 1n            | Film capacitor, 7.2 x 2.5mm |   |
| C9   | 47uF       | 47uF          | Film capacitor, 7.2 x 2.5mm | Power supply filter capacitor.  |
| C10  | 100uF      | 100uF         | Electrolytic capacitor, 5mm | Reference voltage filter capacitor.                                   |
| C11  | 100n       | 100n          | MLCC capacitor, NP0/COG     | Power supply filter capacitor.  |

## PARTS LIST, CONT.

| PART   | VALUE (D+)    | VALUE (250)   | TYPE                           | NOTES   |
|--------|---------------|---------------|--------------------------------|---|
| D1     | 1N5817        | 1N5817        | Schottky diode, DO-41          |   |
| D2     | Ge            | Ge            | Germanium diode                | Can also use a BAT41 Schottky diode here.                             |
| D3     | Ge            | Ge            | Germanium diode                | Can also use a BAT41 Schottky diode here.                             |
| D4     | 1N914         | 1N914         | Fast-switching diode, DO-35    |   |
| D5     | (jumper       | (jumper       | Fast-switching diode, DO-35    | See build notes.  |
| D6     | (jumper)      | (jumper)      | Fast-switching diode, DO-35    | See build notes.  |
| D7     | 1N914         | 1N914         | Fast-switching diode, DO-35    |   |
| D8     | 5mm           | 5mm           | LED, 5mm, red diffused         |   |
| D9     | 5mm           | 5mm           | LED, 5mm, red diffused         |   |
| IC1    | LM741         | LM741         | Operational amplifier, DIP8    |   |
| IC1-S  | DIP-8 socket  | DIP-8 socket  | IC socket, DIP-8               |   |
| GAIN   | 500kC         | 500kC         | 16mm right-angle PCB mount pot |   |
| VOL.   | 50kA          | 100kA         | 16mm right-angle PCB mount pot |   |
| TREBLE | SPDT cntr off | SPDT cntr off | Toggle switch, SPDT on-off-on  |   |
| CLIP   | SPDT cntr off | SPDT cntr off | Toggle switch, SPDT on-off-on  |   |
| LED    | 5mm           | 5mm           | LED, 5mm, red diffused         |   |
| IN     | 1/4" stereo   | 1/4" stereo   | 1/4" phone jack, closed frame  | Switchcraft 112BX or equivalent.                                      |
| OUT    | 1/4" mono     | 1/4" mono     | 1/4" phone jack, closed frame  | Switchcraft 111X or equivalent.                                       |
| DC     | 2.1mm         | 2.1mm         | DC jack, 2.1mm panel mount     | Mouser 163-4302-E or equivalent.                                      |
| BATT   | Battery snap  | Battery snap  | 9V battery snap                | Optional. Use the soft plastic type—the hard-shell type will not fit. |
| FSW    | 3PDT          | 3PDT          | Stomp switch, 3PDT             |   |
| ENC    | 125B          | 125B          | Enclosure, die-cast aluminum   | Can also use a Hammond 1590N1.  |

## BUILD NOTES

---

### C5 feedback capacitor

The Distortion+ and the 250s prior to 1982 did not have a feedback capacitor in the op-amp gain stage, but it's good practice to include one to prevent ultrasonic oscillation by the op-amp. It's recommended to use 10pF for all variants except the later 250s, which use 25pF in the stock configuration. (22pF is the nearest commonly-available value today.)

### Treble switch

The Distortion+ and the earliest 250 had a treble-cut capacitor at the input. These are frequently seen in pedal circuits, but generally they're very low-value capacitors (e.g. 47pF) to tame possible radio interference. In the Distortion+, the value was 1n, and in the 250 it was 2n2. (Later 250 circuits omitted the capacitor entirely, so there was less treble cut than the Distortion+ instead of more.)

The Aphelion puts this capacitor on a switch so you can choose the Dist+ value, the 250 value, or no capacitor at all. This is the default configuration from the parts list (C2 = 1n, C3 = 2n2).

Note that the input treble-cut capacitor works in conjunction with the impedance of what comes before, so it'll have a much different effect if the pedal is getting its signal directly from a guitar or if it's coming from the low-impedance output of an earlier pedal.

The C1 capacitor acts as a "baseline" hi-cut to prevent radio interference even on the center toggle position of the switch. It's recommended to use a 47pF MLCC capacitor here, but it can be omitted if you want a switch position that is 100% stock.

### Clipping switch

The Clipping switch allows you to switch between three sets of diodes, with the default configuration being germanium, silicon and LEDs. The Distortion+ used germanium diodes for clipping, while the 250 used silicon. Clipping LEDs were never used in any version, but it's a popular modification among DIYers.

The PCB has space for two diodes in each direction on the silicon side since this is about halfway between germanium and LEDs in forward voltage. However, if you'd like to have Dist+ clipping on one side and 250 clipping on the other, you'll want to jumper one diode in each direction, e.g. D5 and D6.

The LEDs can be omitted if you want a switch position that lifts the diodes entirely, but there's not a lot of difference between LEDs and no diodes except on the very highest drive settings, so the LEDs are recommended.

If you can't find germanium diodes, the BAT41 Schottky diode can be used as a substitute. It's readily available and should perform very similarly.

Be aware that due to the hard clipping configuration, there will be a large difference in volume between different sets of diodes. The maximum available volume will be lowest with germanium diodes and highest with LEDs or no diodes.

# SCHEMATIC

Schematic shown with Distortion+ values.

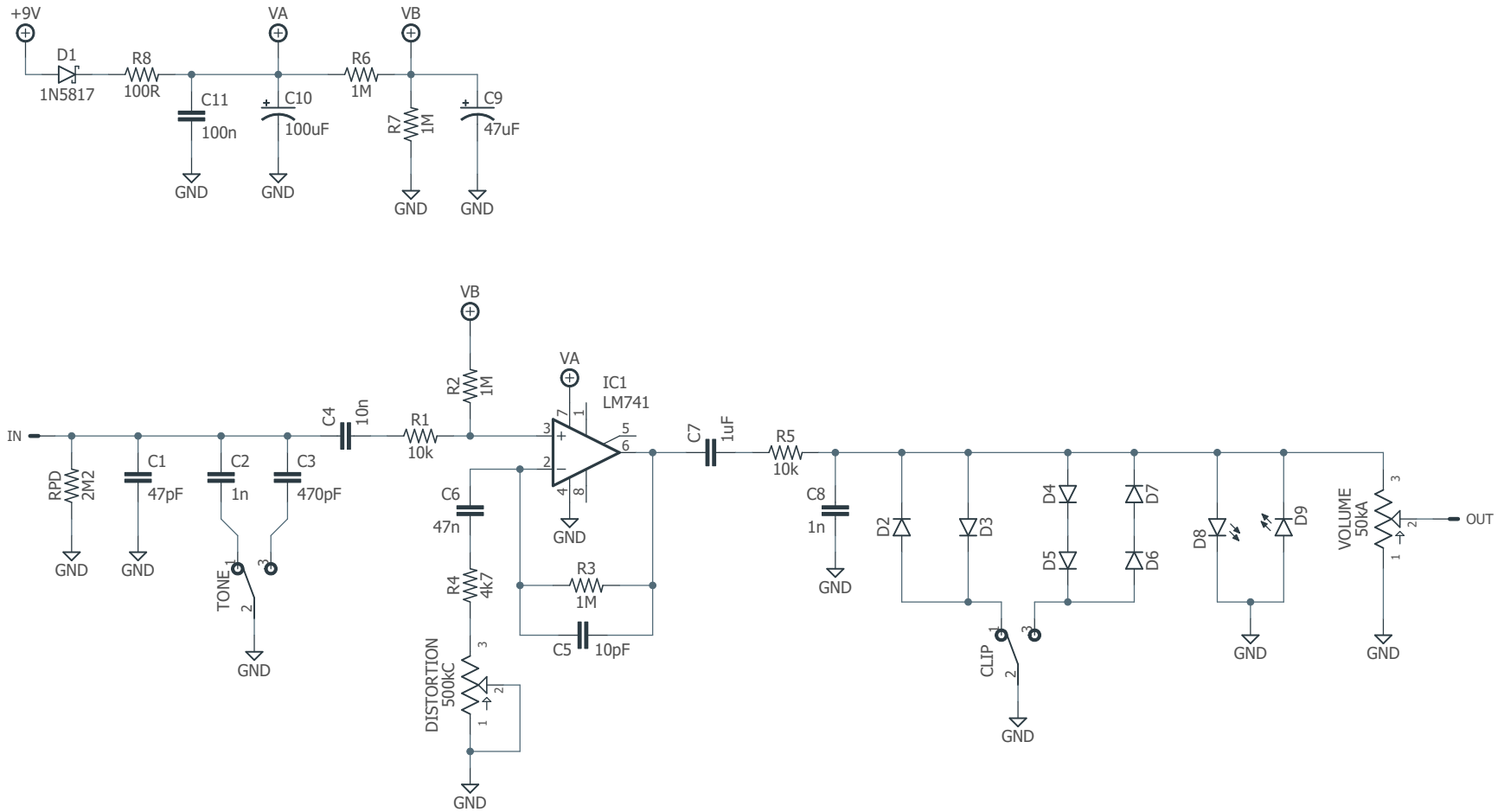

# DRILL TEMPLATE

Cut out this drill template, fold the edges and tape it to the enclosure. Before drilling, it's recommended to first use a center punch for each of the holes to help guide the drill bit.

Ensure that this template is printed at 100% or "Actual Size". You can double-check this by measuring the scale on the printed page.

**Top jack layout** assumes the use of closed-frame jacks like the [Switchcraft 111X](#). If you'd rather use open-frame jacks, please refer to the Open-Frame Jack Drill Template for the top side.

**LED hole drill size** assumes the use of a [5mm LED bezel](#), available from several parts suppliers. Adjust size accordingly if using something different, such as a 3mm bezel, a plastic bezel, or just a plain LED.

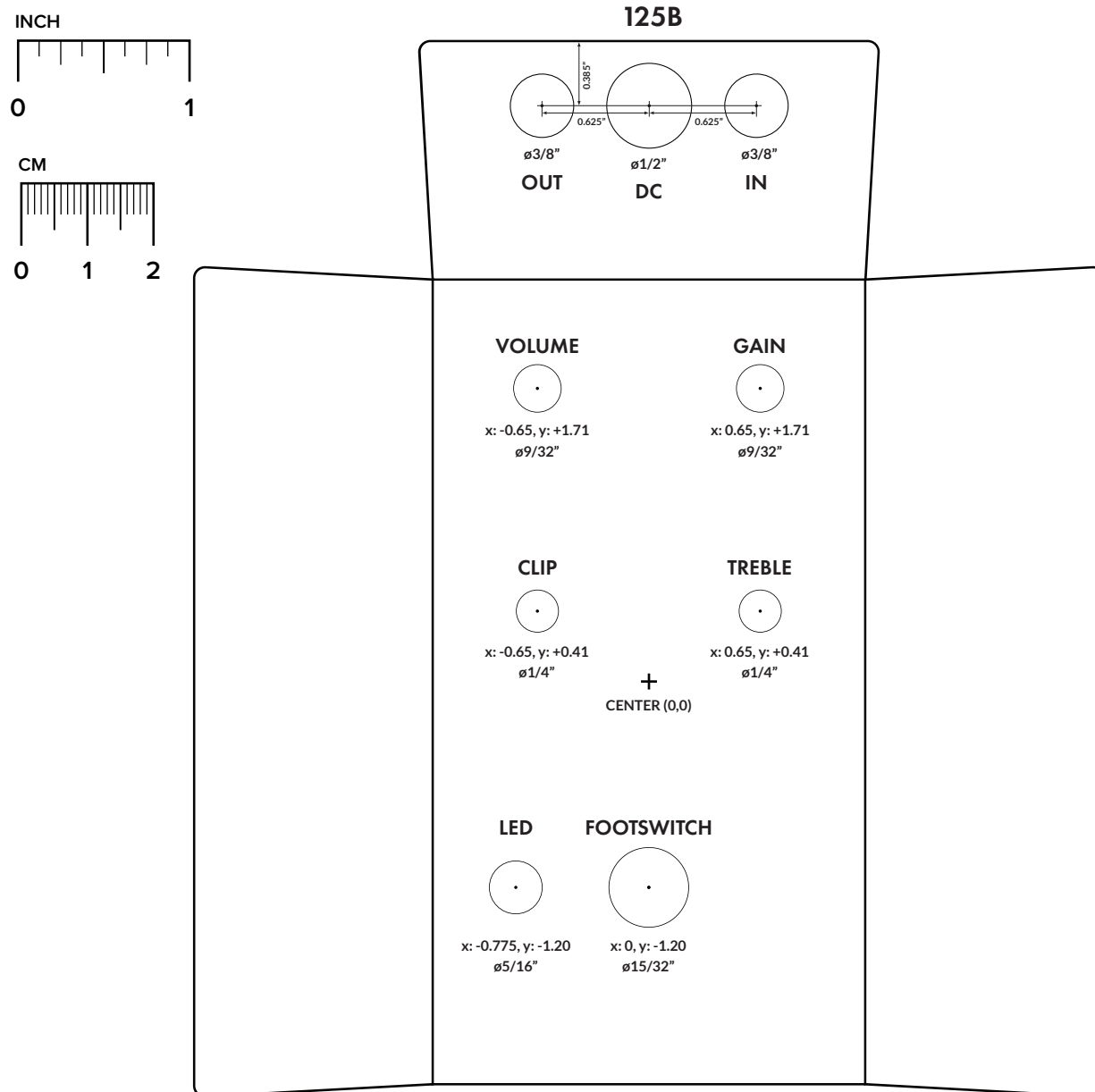

# ENCLOSURE LAYOUT

---

Enclosure is shown without jacks. See next page for jack layout and wiring.

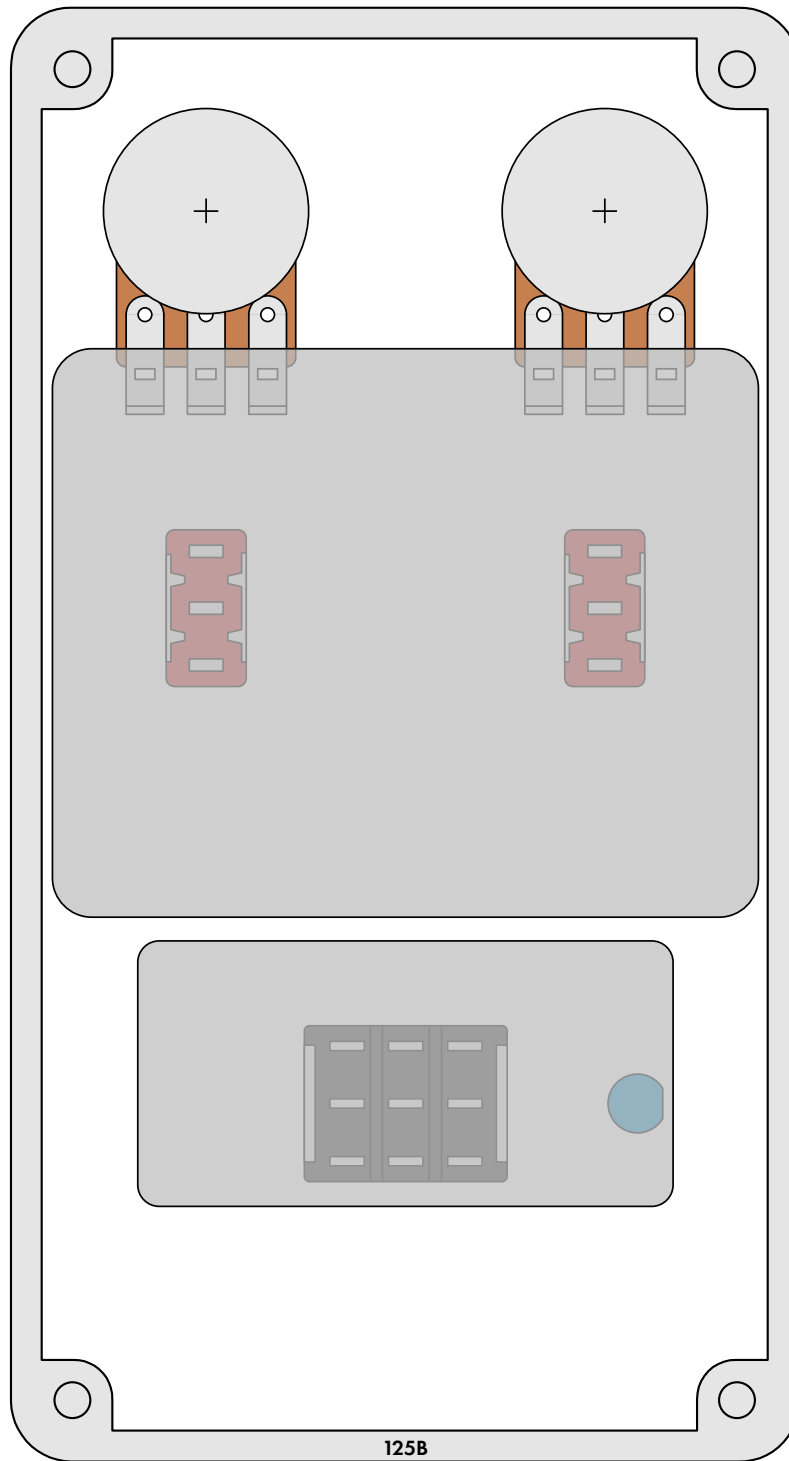



# WIRING DIAGRAM



*Shown with optional 9V battery. If battery is omitted, both jacks can be mono rather than one being stereo.  
Leave the far-right lug of the DC jack unconnected.*

## LICENSE & USAGE

---

**No direct support is offered for these projects beyond the provided documentation.** It's assumed that you have at least some experience building pedals before starting one of these. Replacements and refunds cannot be offered unless it can be shown that the circuit or documentation are in error.

**All of these circuits have been tested in good faith in their base configurations.** However, not all the modifications or variations have necessarily been tested. These are offered only as suggestions based on the experience and opinions of others.

**Projects may be used for commercial endeavors in any quantity** unless specifically noted. No attribution is necessary, though a link back is always greatly appreciated. The only usage restrictions are that **(1) you cannot resell the PCB as part of a kit without prior arrangement, and (2) you cannot "goop" the circuit, scratch off the screenprint, or otherwise obfuscate the circuit to disguise its source.** (In other words: you don't have to go out of your way to advertise the fact that you use these PCBs, but please don't go out of your way to hide it. The guitar effects industry needs more transparency, not less!)

## DOCUMENT REVISIONS

---

### 1.0.1 (2020-09-28)

Added missing IC1 (LM741) to parts list.

### 1.0.0 (2020-08-28)

Initial release.