

PROJECT NAME

ANDROMEDA



BASED ON

Nobels ODR-1 Natural Overdrive

BUILD DIFFICULTY

■■■■□ Intermediate

EFFECT TYPE

Overdrive

DOCUMENT VERSION

1.0.3 (2024-08-08)

PROJECT SUMMARY

A unique overdrive pedal whose complex drive tone earns it a spot on the pedalboards of many Nashville studio musicians.

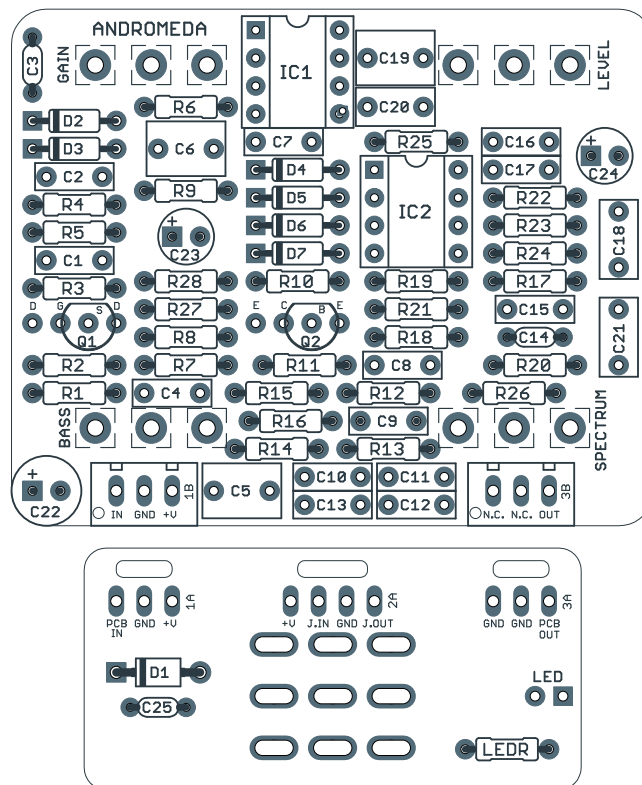

Actual size is 2.3" x 1.86" (main board) and 2.3" x 0.86" (bypass board).

IMPORTANT NOTE

This documentation is for the **PCB-only** version of the project. If you are building the full kit from Aion FX, please use the [kit build documentation](#) instead. The instructions are more detailed and may differ in some areas due to the specialized parts and assembly methods used in our kits.

TABLE OF CONTENTS

1	Project Overview	8	Drill Template
2	Introduction & Usage	9	Enclosure Layout
3-5	Parts List	10	Wiring Diagram
6	Build Notes	11	Licensing
7	Schematic	11	Document Revisions

INTRODUCTION

The Andromeda Natural Overdrive is a recreation of the Nobels ODR-1, a somewhat obscure pedal from Germany that nonetheless is considered a “secret weapon” among Nashville studio musicians.

The primary complaint of the ODR-1 is that it has way too much bass with no way to dial it out. To that end, this project incorporates a variable bass control inspired by the Timmy and Zendrive. The stock tones are still there with the knob all the way up, but now you have the option to dial it back.

Looking at the schematic, you can see a stark difference with Japanese-designed pedals (i.e. most Ibanez & Boss circuits). This is German engineering at its finest—tons of odd-value resistors and capacitors forming very precise filters and signal shaping. This is not a particularly simple build, but it’s very rewarding and well worth the effort.

The updated 125B version of the Andromeda has a new layout but is otherwise identical to the earlier 1590B version. No features were added or removed.

USAGE

The Andromeda has four controls:

- **Gain** controls the amount of gain from the op amp that is fed through the feedback clipping diodes.
- **Spectrum** is a very non-standard tone control of sorts. You can pan between a 700 Hz lowpass filter and a 5 KHz high-pass filter, which is mixed with a fixed 2.1 KHz frequency boost (upper mids). This control is much more complex than your standard high-cut or Tube Screamer style tone control.
- **Bass** allows you to adjust the bass response of the circuit. The stock ODR-1 circuit is the equivalent of having the Bass knob turned all the way up.
- **Level** sets the overall output of the effect.

PARTS LIST

This parts list is also available in a spreadsheet format which can be imported directly into Mouser for easy parts ordering. Mouser doesn't carry all the parts—notably potentiometers—so the second tab lists all the non-Mouser parts as well as sources for each.

[View parts list spreadsheet](#) →

PART	VALUE	TYPE	NOTES
R1	33k	Metal film resistor, 1/4W	
R2	1M	Metal film resistor, 1/4W	
R3	3k3	Metal film resistor, 1/4W	
R4	2k7	Metal film resistor, 1/4W	
R5	10k	Metal film resistor, 1/4W	
R6	1k8	Metal film resistor, 1/4W	
R7	820R	Metal film resistor, 1/4W	
R8	1k5	Metal film resistor, 1/4W	
R9	12K	Metal film resistor, 1/4W	
R10	39K	Metal film resistor, 1/4W	
R11	10K	Metal film resistor, 1/4W	
R12	12k	Metal film resistor, 1/4W	
R13	5k1	Metal film resistor, 1/4W	
R14	2k2	Metal film resistor, 1/4W	
R15	150K	Metal film resistor, 1/4W	
R16	3k3	Metal film resistor, 1/4W	
R17	1k2	Metal film resistor, 1/4W	
R18	43K	Metal film resistor, 1/4W	
R19	10K	Metal film resistor, 1/4W	
R20	20K	Metal film resistor, 1/4W	
R21	4k7	Metal film resistor, 1/4W	
R22	22K	Metal film resistor, 1/4W	
R23	5k1	Metal film resistor, 1/4W	
R24	1k2	Metal film resistor, 1/4W	
R25	150K	Metal film resistor, 1/4W	
R26	150K	Metal film resistor, 1/4W	
R27	15K	Metal film resistor, 1/4W	
R28	15K	Metal film resistor, 1/4W	
LEDR	10k	Metal film resistor, 1/4W	LED current-limiting resistor. Adjust value to change LED brightness.

PARTS LIST, CONT.

PART	VALUE	TYPE	NOTES
C1	68n	Film capacitor, 7.2 x 2.5mm	
C2	22n	Film capacitor, 7.2 x 2.5mm	
C3	120pF	MLCC capacitor, NP0/COG	
C4	82n	Film capacitor, 7.2 x 2.5mm	
C5	2.2uF	Film capacitor, 7.2 x 5mm	
C6	2.2uF	Film capacitor, 7.2 x 5mm	
C7	2n7	Film capacitor, 7.2 x 2.5mm	
C8	82n	Film capacitor, 7.2 x 2.5mm	
C9	1n	Film capacitor, 7.2 x 2.5mm	
C10	22n	Film capacitor, 7.2 x 2.5mm	
C11	27n	Film capacitor, 7.2 x 2.5mm	
C12	100n	Film capacitor, 7.2 x 2.5mm	
C13	8n2	Film capacitor, 7.2 x 2.5mm	
C14	560pF	MLCC capacitor, NP0/COG	
C15	8n2	Film capacitor, 7.2 x 2.5mm	
C16	4n7	Film capacitor, 7.2 x 2.5mm	
C17	82n	Film capacitor, 7.2 x 2.5mm	
C18	1uF	Film capacitor, 7.2 x 3.5mm	
C19	2.2uF	Film capacitor, 7.2 x 5mm	
C20	470n	Film capacitor, 7.2 x 3.5mm	
C21	1uF	Film capacitor, 7.2 x 3.5mm	
C22	100uF	Electrolytic capacitor, 6.3mm	Power supply filter capacitor.
C23	47uF	Electrolytic capacitor, 5mm	Reference voltage filter capacitor.
C24	47uF	Electrolytic capacitor, 5mm	Reference voltage filter capacitor.
C25	100n	MLCC capacitor, X7R	Power supply filter capacitor.
D1	1N5817	Schottky diode, DO-41	
D2	1N914	Fast-switching diode, DO-35	
D3	1N914	Fast-switching diode, DO-35	
D4	1N914	Fast-switching diode, DO-35	
D5	1N914	Fast-switching diode, DO-35	
D6	1N914	Fast-switching diode, DO-35	Optional. Bridge the jumper pads between D6 and D7 for the stock ODR-1 circuit.
D7	1N914	Fast-switching diode, DO-35	Optional. Bridge the jumper pads between D6 and D7 for the stock ODR-1 circuit.

PARTS LIST, CONT.

PART	VALUE	TYPE	NOTES
Q1	2N5457	JFET, N-channel, TO-92	Commonly-available substitute. Original uses BC264D.
Q2	2N5088	BJT transistor, NPN, TO-92	Commonly-available substitute. Original uses 2SC2362G.
IC1	JRC4558D	Operational amplifier, DIP8	
IC2	JRC4558D	Operational amplifier, DIP8	
IC1-S	DIP-8 socket	IC socket, DIP-8	
IC2-S	DIP-8 socket	IC socket, DIP-8	
GAIN	250kA	16mm right-angle PCB mount pot	
LEVEL	50kA	16mm right-angle PCB mount pot	
SPECT	25kB	16mm right-angle PCB mount pot	
BASS	50kC	16mm right-angle PCB mount pot	Modification. Turn it all the way up for the stock ODR-1 circuit.
LED	5mm	LED, 5mm, red diffused	
IN	1/4" stereo	1/4" phone jack, closed frame	Switchcraft 112BX or equivalent.
OUT	1/4" mono	1/4" phone jack, closed frame	Switchcraft 111X or equivalent.
DC	2.1mm	DC jack, 2.1mm panel mount	Mouser 163-4302-E or equivalent.
BATT	Battery snap	9V battery snap	Optional. Use the soft plastic type—the hard-shell type will not fit.
FSW	3PDT	Stomp switch, 3PDT	
ENC	125B	Enclosure, die-cast aluminum	Can also use a Hammond 1590N1.

BUILD NOTES

Bass Control

Most drive pedals will cut bass before clipping the signal. The classic benchmark is the Tube Screamer's 720Hz filter, and most drive pedals are somewhere in this range.

The stock ODR-1 does not have very much bass-cut, and so in most rigs, it has an enormous low end that doesn't work very well. This is the biggest complaint about the circuit and is the fatal flaw in an otherwise exceptional design.

Fortunately, it's an easy problem to solve. By adding a Bass control to allow the bass to be cut down to reasonable levels, the Andromeda becomes an incredibly usable drive effect. And with the knob all the way up, it's exactly like the stock ODR-1 circuit.

If for some reason you do want to leave off this control, you can jumper pins 2 and 3 of the Bass pot to eliminate it entirely.

Clipping Diodes

The ODR-1 circuit uses both soft clipping diodes (op-amp feedback) and hard clipping diodes (signal to ground). The hard clipping diodes clip the signal pretty aggressively, and as a result, they remove some of the character of the effect.

The Andromeda has been modified to have two extra diodes, D6 and D7, in series with the existing hard-clipping diodes. It's recommended to use these. However, they are not on a switch that allows them to be toggled in and out, so they can't be added and removed on a whim.

If you don't want to use the additional diodes, you can either run jumper wires across them or you can just bridge the two jumper pads to the immediate left of D7.

SCHEMATIC

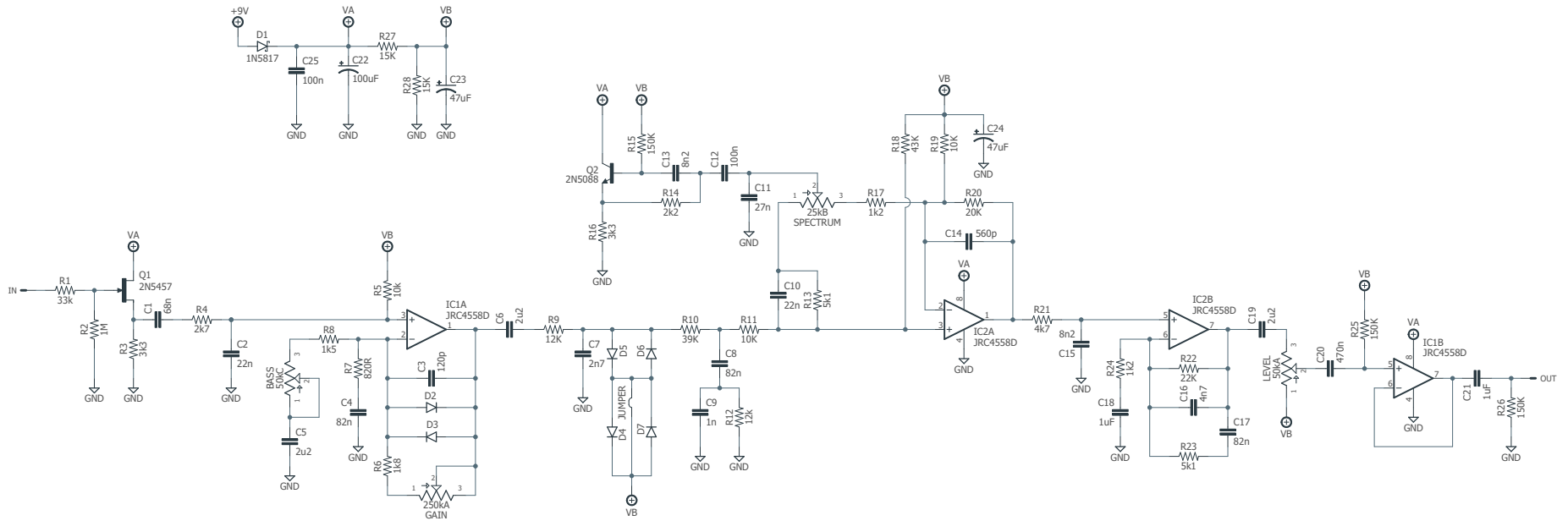

DRILL TEMPLATE

Cut out this drill template, fold the edges and tape it to the enclosure. Before drilling, it's recommended to first use a center punch for each of the holes to help guide the drill bit.

Ensure that this template is printed at 100% or "Actual Size". You can double-check this by measuring the scale on the printed page.

Top jack layout assumes the use of closed-frame jacks like the [Switchcraft 111X](#). If you'd rather use open-frame jacks, please refer to the [Open-Frame Jack Drill Template](#) for the top side.

LED hole drill size assumes the use of a [5mm LED bezel](#), available from several parts suppliers. Adjust size accordingly if using something different, such as a 3mm bezel, a plastic bezel, or just a plain LED.

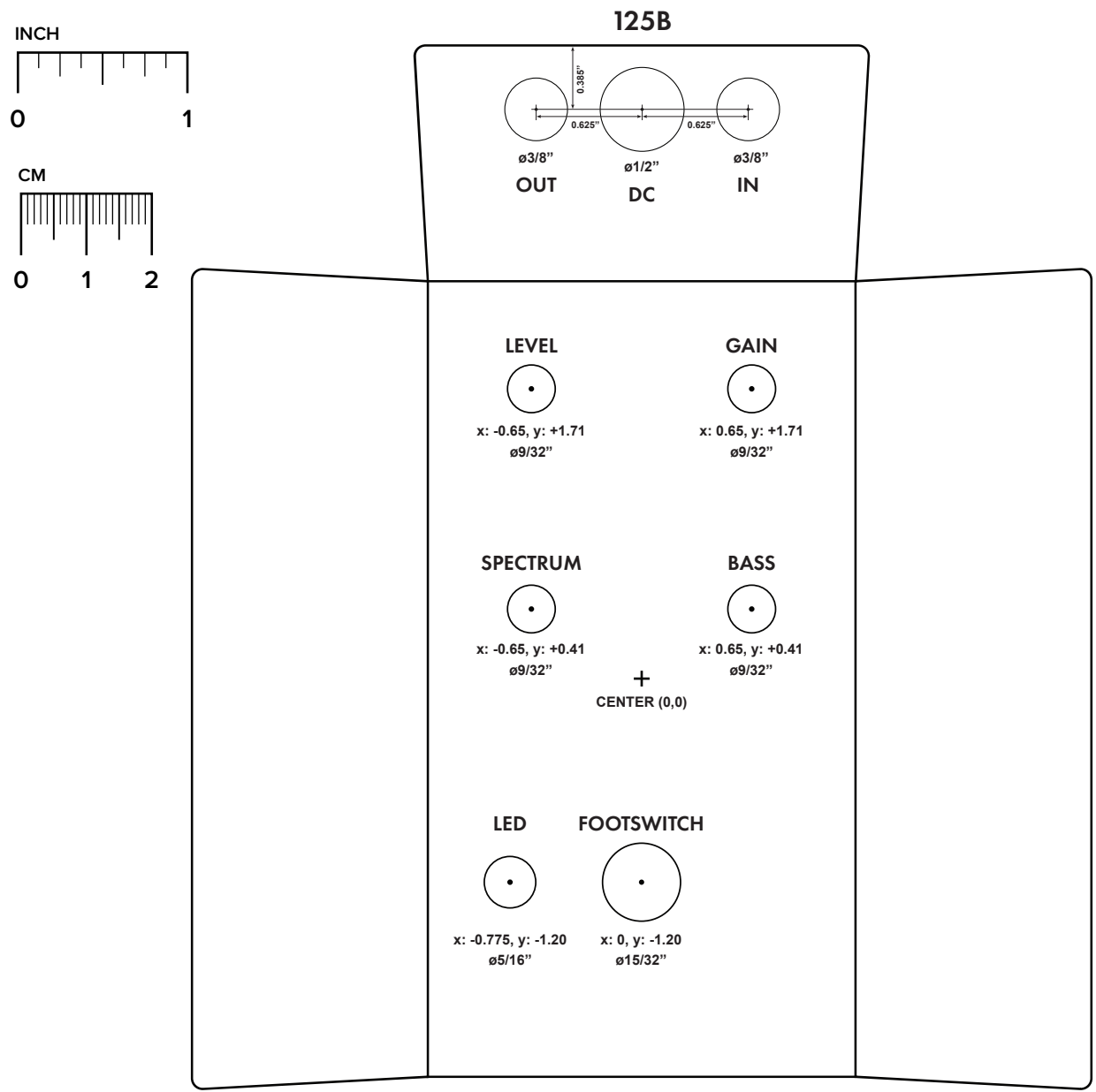

ENCLOSURE LAYOUT

Enclosure is shown without jacks. See next page for jack layout and wiring.

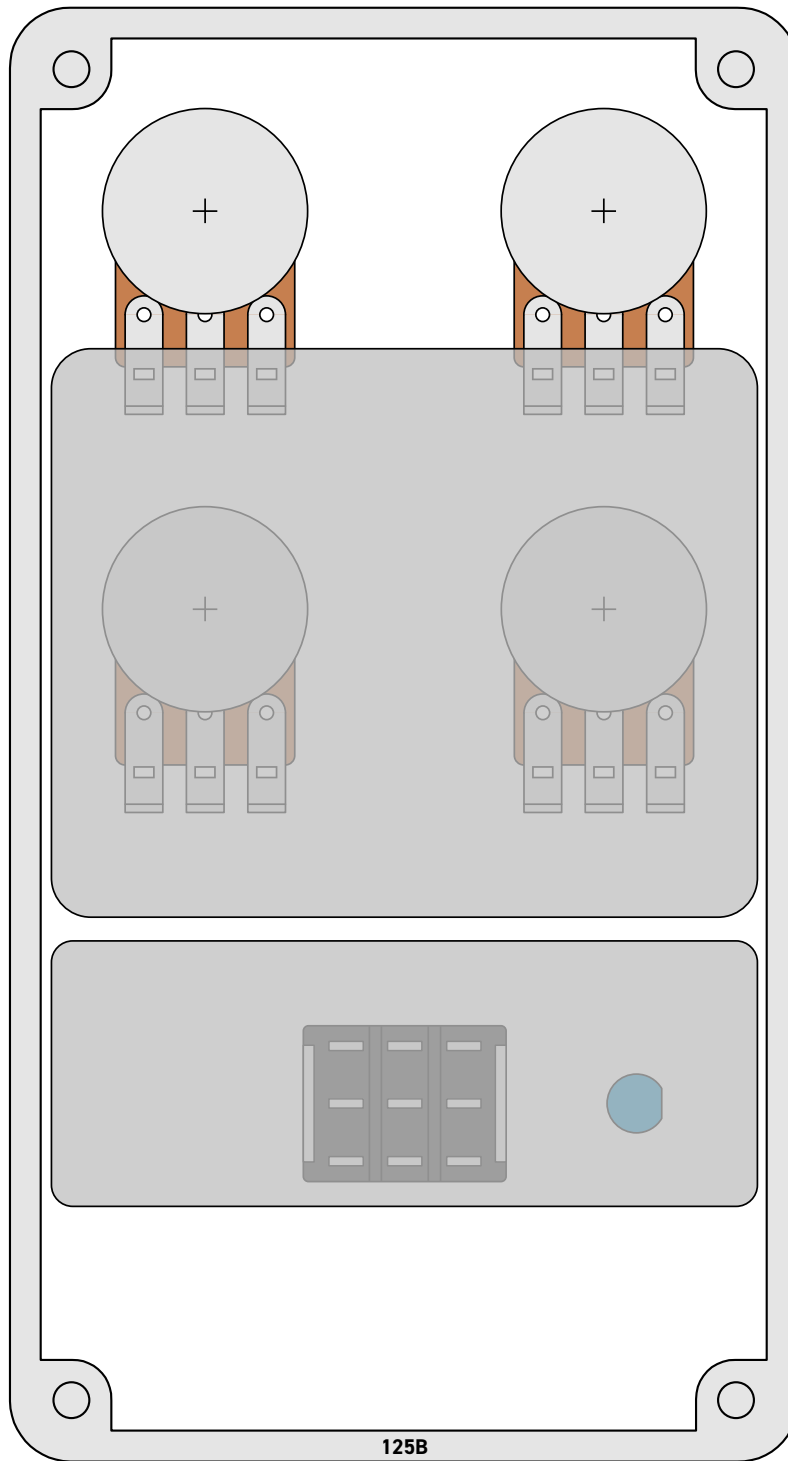

LICENSE & USAGE

No direct support is offered for these projects beyond the provided documentation. It's assumed that you have at least some experience building pedals before starting one of these. Replacements and refunds cannot be offered unless it can be shown that the circuit or documentation are in error.

All of these circuits have been tested in good faith in their base configurations. However, not all the modifications or variations have necessarily been tested. These are offered only as suggestions based on the experience and opinions of others.

Projects may be used for commercial endeavors in any quantity unless specifically noted. No attribution is necessary, though a link back is always greatly appreciated. The only usage restrictions are that **(1) you cannot resell the PCB as part of a kit without prior arrangement, and (2) you cannot "goop" the circuit, scratch off the screenprint, or otherwise obfuscate the circuit to disguise its source.** (In other words: you don't have to go out of your way to advertise the fact that you use these PCBs, but please don't go out of your way to hide it. The guitar effects industry needs more transparency, not less!)

DOCUMENT REVISIONS

1.0.3 (2024-08-08)

Changed LEDR to 10k to work with a wider variety of LEDs.

1.0.2 (2020-10-29)

Updated links for new website.

1.0.1 (2019-07-28)

Removed RPD from parts list. (Not used in this circuit.)

1.0.0 (2018-08-22)

Initial release.