

PROJECT NAME  
**VULCAN**

BASED ON  
fOXX Tone Machine

EFFECT TYPE  
Octave Fuzz

PROJECT SUMMARY

A classic untamed fuzz from the 1970s that adds an octave-up overtone.

BUILD DIFFICULTY  
■■■■■ Easy

DOCUMENT VERSION  
1.1.0 (2020-06-06)

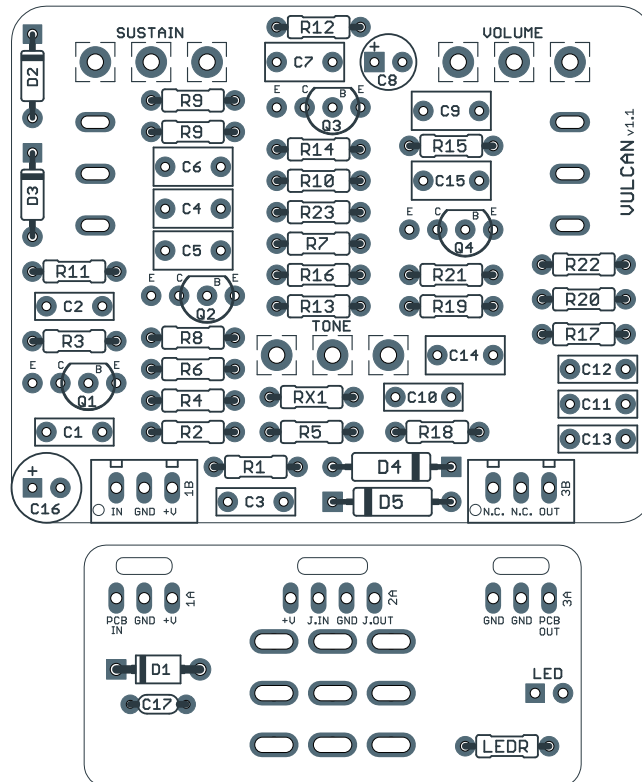

Actual size is 2.3" x 1.86" (main board) and 1.78" x 0.86" (bypass board).

# TABLE OF CONTENTS

---

1	Project Overview	7	Drill Template
2	Introduction & Usage	8	Enclosure Layout
3-4	Parts List	9	Wiring Diagram
5	Build Notes	10	Licensing
6	Schematic	10	Document Revisions

## INTRODUCTION

---

The Vulcan Octave Fuzz is a recreation of the fOXX Tone Machine, first released in 1971 and discontinued in 1978. The Tone Machine is a thick fuzz that uses a phase splitter and complementary rectifier to create an octave overtone.

The Tone Machine has a lot in common with the Fender Blender, but with a more pronounced octave and smoother tone, as well as the ability to disable the octave by turning off half of the phase splitter.

The Vulcan is faithful to the original, but with two added modifications. First, the octave switch (normally just “on” or “off” in the original) now has a 3rd setting allowing you to bypass the series diode in non-octave mode. See build notes for more details on this.

The second modification is to the tone control. The tone control of the original is somewhat similar to the Big Muff, but many people find it’s difficult to get good sounds from the treble side of the rotation. By increasing the value of the treble-side tone capacitor, it improves the usability. A switch has been added to let you choose between two different capacitors in addition to the original.

The build notes for the Vulcan are pretty extensive, so make sure to read pages 5 and 6 before building.

## USAGE

---

The Vulcan has the following controls:

- **Sustain** is the overall distortion or fuzz level of the effect.
- **Tone** pans between a low-pass and high-pass filter similar to a Big Muff tone control.
- **Volume** controls the overall output of the effect.
- **Octave** (toggle switch) selects between octave, no octave (original) and no octave (modified).
- **Midrange** (toggle switch) selects between two tone control capacitors that impact the midrange frequencies, as well as allowing you to select just the stock capacitor.

## PARTS LIST

This parts list is also available in a spreadsheet format which can be imported directly into Mouser for easy parts ordering. Mouser doesn't carry all the parts (most notably potentiometers) so the second tab lists all the non-Mouser parts as well as sources for each.

[View parts list spreadsheet](#) →

PART	VALUE	TYPE	NOTES
R1	1M	Metal film resistor, 1/4W	
R2	47k	Metal film resistor, 1/4W	
R3	1k	Metal film resistor, 1/4W	
R4	47k	Metal film resistor, 1/4W	
R5	100k	Metal film resistor, 1/4W	
R6	100k	Metal film resistor, 1/4W	
R7	4k7	Metal film resistor, 1/4W	
R8	4k7	Metal film resistor, 1/4W	
R9	12k	Metal film resistor, 1/4W	This is the top R9 resistor, immediately below the Sustain control.
R9	100k	Metal film resistor, 1/4W	This is the bottom R9 resistor, immediately below the other R9.
R10	100k	Metal film resistor, 1/4W	
R11	100k	Metal film resistor, 1/4W	
R12	220R	Metal film resistor, 1/4W	
R13	150k	Metal film resistor, 1/4W	
R14	15k	Metal film resistor, 1/4W	Some variants have a 1n capacitor in parallel with R14.
R15	1k	Metal film resistor, 1/4W	
R16	10k	Metal film resistor, 1/4W	
R17	22k	Metal film resistor, 1/4W	
R18	4k7	Metal film resistor, 1/4W	Jumper for more control over bass range.
R19	470k	Metal film resistor, 1/4W	
R20	47k	Metal film resistor, 1/4W	
R21	10k	Metal film resistor, 1/4W	
R22	1k5	Metal film resistor, 1/4W	
R23	100k	Metal film resistor, 1/4W	Prevents popping when switching in & out of octave mode.
RX1	OMIT	Metal film resistor, 1/4W	Modification for more pronounced filter, similar to Big Muff tone stage. Leave empty for stock, or use 22k here for modification.
C1	100n	Film capacitor, 7.2 x 2.5mm	
C2	1n	Film capacitor, 7.2 x 2.5mm	
C3	100n	Film capacitor, 7.2 x 2.5mm	
C4	1uF	Film capacitor, 7.2 x 3.5mm	
C5	1uF	Film capacitor, 7.2 x 3.5mm	

## PARTS LIST, CONT.

PART	VALUE	TYPE	NOTES
C6	1uF	Film capacitor, 7.2 x 3.5mm	
C7	1uF	Film capacitor, 7.2 x 3.5mm	
C8	22uF	Electrolytic capacitor, 5mm	Original units used 10uF capacitors, but many were off-spec and actually measured 22uF.
C9	1uF	Film capacitor, 7.2 x 3.5mm	
C10	1n	Film capacitor, 7.2 x 2.5mm	
C11	2n2	Film capacitor, 7.2 x 2.5mm	Modification - alternate capacitors for tone section, switched in via the Midrange switch. Use 1n8 for red (late) specs. See build notes for more.
C12	15n	Film capacitor, 7.2 x 2.5mm	Modification - alternate capacitors for tone section, switched in via the Midrange switch.
C13	47n	Film capacitor, 7.2 x 2.5mm	
C14	1uF	Film capacitor, 7.2 x 3.5mm	
C15	1uF	Film capacitor, 7.2 x 3.5mm	
C16	100uF	Electrolytic capacitor, 6.3mm	Power supply filter capacitor.
C17	100n	MLCC capacitor, X7R	Power supply filter capacitor.
D1	1N5817	Schottky diode, DO-41	
D2	BAT46	Schottky diode, DO-35	Substitute. Original uses 1N34A or other germanium.
D3	BAT46	Schottky diode, DO-35	Substitute. Original uses 1N34A or other germanium.
D4	1N34A	Diode, germanium, NOS	
D5	1N34A	Diode, germanium, NOS	
Q1	2N5089	BJT transistor, NPN, TO-92	Modern substitute. The original used 2N3565 or 2N5133. For best results, sort for hFE (gain) of 400 or more.
Q2	2N5089	BJT transistor, NPN, TO-92	
Q3	2N5089	BJT transistor, NPN, TO-92	
Q4	2N5089	BJT transistor, NPN, TO-92	
SUST.	50kB	16mm right-angle PCB mount pot	
TONE	50kB	16mm right-angle PCB mount pot	
VOL.	50kB	16mm right-angle PCB mount pot	
MID	SPDT	Toggle switch, SPDT on-on	Modification to improve usefulness of tone control. See build notes.
OCTAVE	SPDT cntr off	Toggle switch, SPDT on-off-on	Slight modification to the original. See build notes.
LED	5mm	LED, 5mm, red diffused	
IN	1/4" stereo	1/4" phone jack, closed frame	Switchcraft 112BX or equivalent.
OUT	1/4" mono	1/4" phone jack, closed frame	Switchcraft 111X or equivalent.
DC	2.1mm	DC jack, 2.1mm panel mount	Mouser 163-4302-E or equivalent.
BATT	Battery snap	9V battery snap	Optional. Use the soft plastic type—the hard-shell type will not fit.
FSW	3PDT	Stomp switch, 3PDT	
ENC	125B	Enclosure, die-cast aluminum	Can also use a Hammond 1590N1.

# BUILD NOTES

---

## Version 1.1 updates

Version 1.1 of the PCB (April 2020) adds two new resistors, R23 and a second R9. (The second R9 was labeled by mistake—it should have been labeled R24.) The top R9 is 12k and the bottom R9 is 100k. R23 is 100k. These are the only changes to the circuit board.

## Tracing notes: early vs. late version

Since releasing the Vulcan initially, Aion FX had the opportunity to trace two original Tone Machines, an early blue one and a later red one. The early version is identical to the commonly available schematics. The differences in the red version are very minor:

1. 12k series resistor added to the Sustain control to drop the maximum amount of sustain slightly.
2. The treble-side tone capacitor, normally 3n3, has been reduced to 2n7.
3. The transistors (still 2N3565) are sorted for higher gain, 400+.

In addition, another thing we noticed in tracing is that the C8 capacitor measured right around 22uF (nominally 10uF). This did have an impact on the bass content of the tone, so if you want it to sound like a real vintage unit then use 22uF.

## Tone capacitor

The red version of the Tone Machine used 2n7 for the tone capacitor instead of 3n3. Due to the midrange switch in the Vulcan, the corresponding tone capacitor is a combination of C10 + C11 (1n + 2n2 = 3n3). So, if you want to use the red value, we recommend using a 1n8 capacitor for C11 for a combined value of 2n8.

## Transistor selection

While the 2N3565 was the only transistor used throughout the run of the Tone Machine, the gain of those transistors was very different. Early units had gains around 230-250 while later units were over 450. Here is a chart of the gain (hFE) of the transistors that we measured in two vintage units:

PART	BLUE (EARLY)	RED (LATE)
Q1	245	549
Q2	230	451
Q3	240	456
Q4	230	455

If you are building to “early specs” then 2N3904 is a good option, though it’s typically a little lower gain than these. For “late specs”, the 2N5089 or 2N5088 will get you there.

## **BUILD NOTES, CONT.**

---

### **Tone control modifications**

#### **Midrange switch**

The Tone Machine's tone control is reminiscent of the Big Muff in its topology, but missing a resistor to ground on the treble side to complete the filter, and with a very low value for the treble capacitor, which makes it a little harsh on higher settings. By changing the capacitor to a higher value, the frequency range is increased and the treble side of the control becomes a lot more usable.

#### **Big Muff resistor**

As mentioned previously, the tone control is one resistor away from a Big Muff tone control. An optional resistor, RX1, has been added in case you want to experiment to see how it sounds. Start with 22k as a value. R17 and C13 can be adjusted as well to match a Big Muff variant.

#### **Minimum bass value resistor**

R18 sets the minimum value for the bass side of the knob rotation, setting it approximately 10% higher than a standard Big Muff tone section. If you want more bass (especially if using modified filter values to be more like a Big Muff) then you may want to jumper this resistor to give the control more range.

#### **Octave switch**

The octave in this effect is generated by splitting the signal into two, one in-phase and one out of phase, and then rectifying the signals to cancel out half of the waveform of each. The signals are then combined back together which emphasizes the octave overtone.

The octave switch lets you disable half of the phase splitter to cancel out the octave effect. However, the non-octave signal still passes through a series diode (D2) which introduces something called "crossover distortion". While this crossover distortion is part of the sound of the Tone Machine, it sounds very good without it as well and justifies having its own setting.

As a result, the octave switch has been modified to have Octave, No Octave (original) and No Octave (modified) settings.

#### **R23 resistor**

In Version 1.1 of the Vulcan, a new resistor (R23) was added to one half of the octave generation path. This is a counterpart to R10 that ensures that both sides of the octave signal are held at the same DC voltage.

The vintage Tone Machine units were missing this resistor, so they had a pop when switching the octave on and off. This can be considered a design flaw in the original units. There is no change to the tone by adding this resistor since it only impacts the DC voltage, not AC (signal), but it can be omitted if you want it to be 100% stock.

# SCHEMATIC

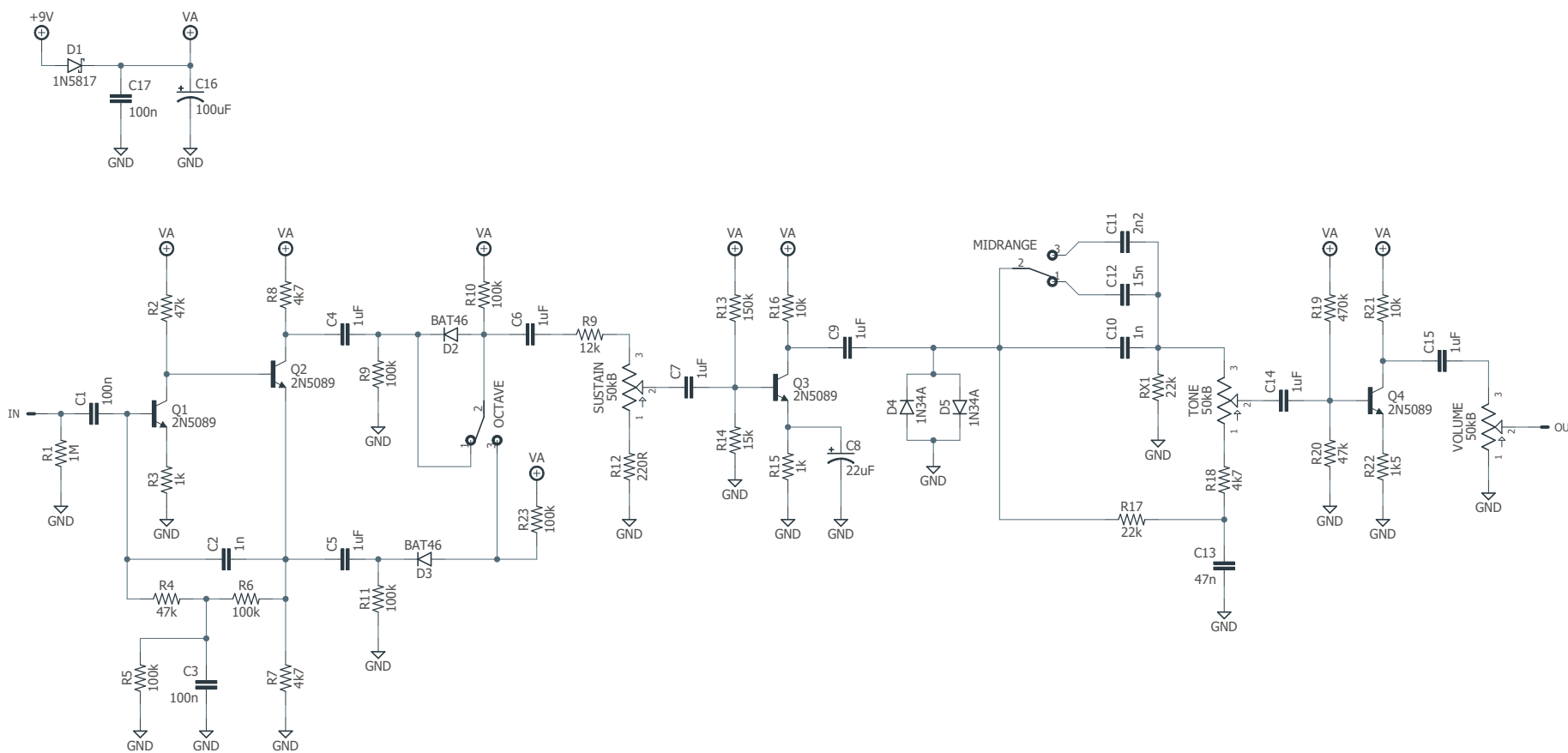

# DRILL TEMPLATE

Cut out this drill template, fold the edges and tape it to the enclosure. Before drilling, it's recommended to first use a center punch for each of the holes to help guide the drill bit.

Ensure that this template is printed at 100% or "Actual Size". You can double-check this by measuring the scale on the printed page.

**Top jack layout** assumes the use of closed-frame jacks like the [Switchcraft 111X](#). If you'd rather use open-frame jacks, please refer to the [Open-Frame Jack Drill Template](#) for the top side.

**LED hole drill size** assumes the use of a [5mm LED bezel](#), available from several parts suppliers. Adjust size accordingly if using something different, such as a 3mm bezel, a plastic bezel, or just a plain LED.

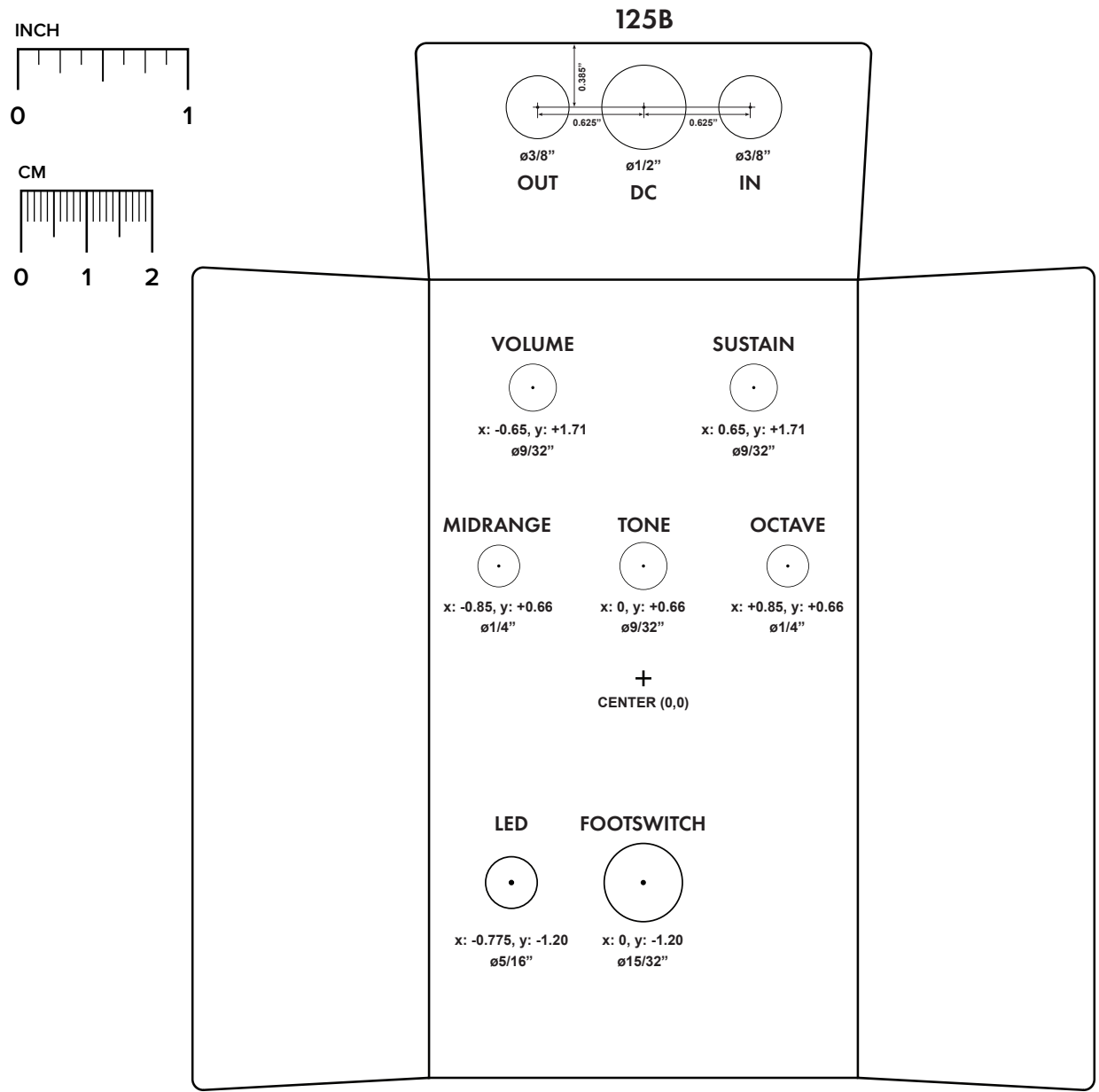



# ENCLOSURE LAYOUT

---

Enclosure is shown without jacks. See next page for jack layout and wiring.

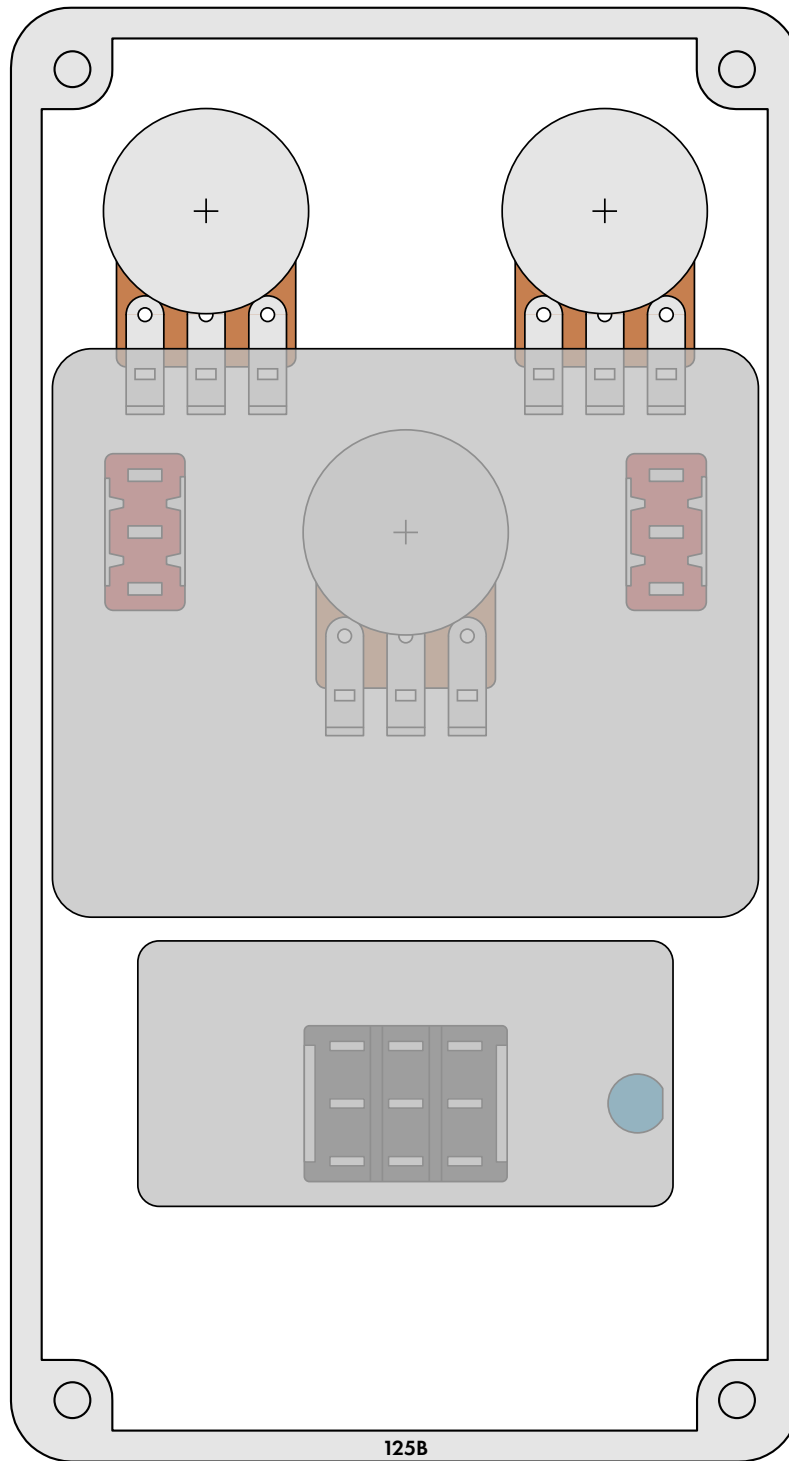

# WIRING DIAGRAM

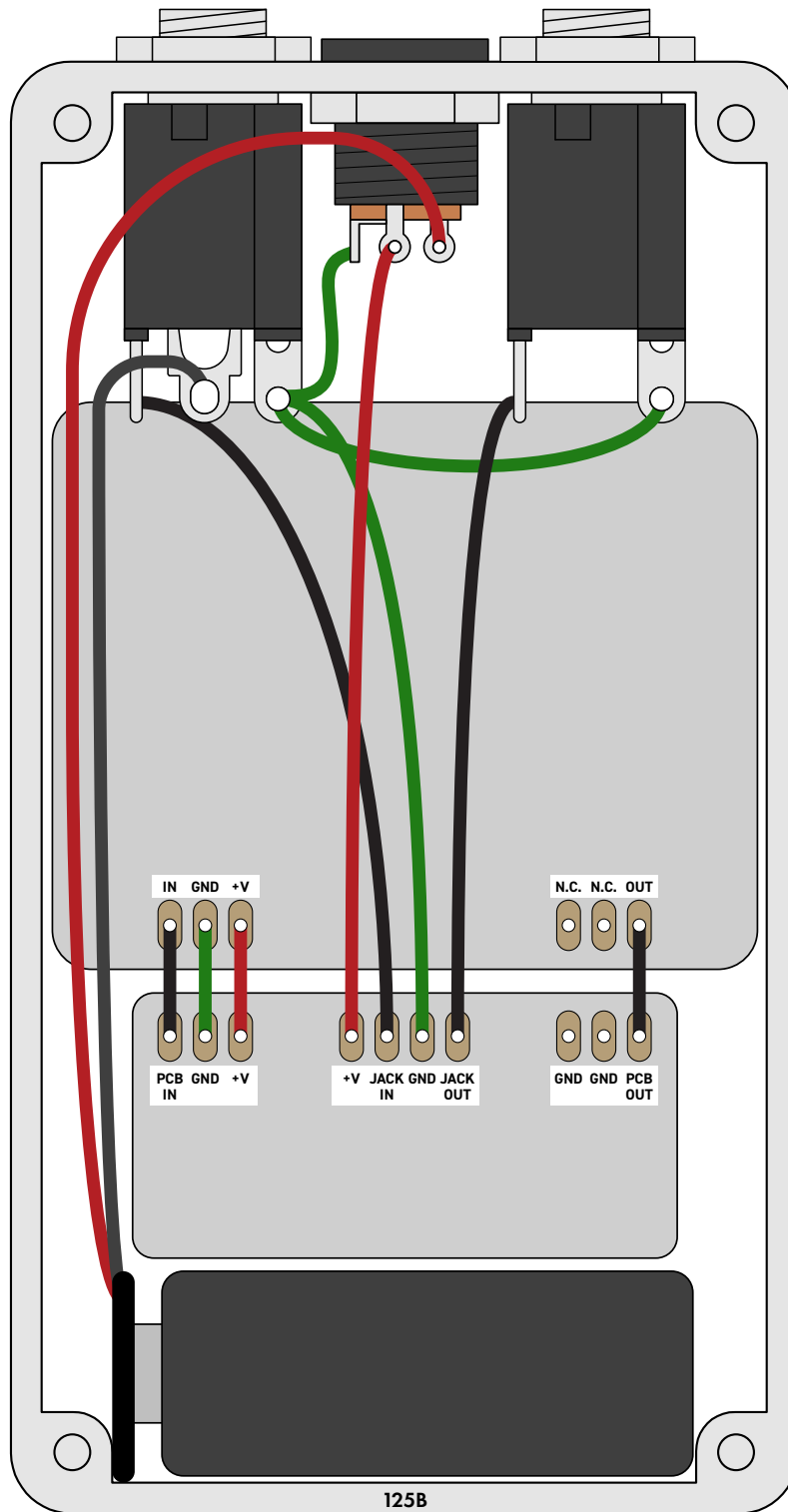

*Shown with optional 9V battery. If battery is omitted, both jacks can be mono rather than one being stereo.  
Leave the far-right lug of the DC jack unconnected.*

## LICENSE & USAGE

---

**No direct support is offered for these projects beyond the provided documentation.** It's assumed that you have at least some experience building pedals before starting one of these. Replacements and refunds cannot be offered unless it can be shown that the circuit or documentation are in error.

**All of these circuits have been tested in good faith in their base configurations.** However, not all the modifications or variations have necessarily been tested. These are offered only as suggestions based on the experience and opinions of others.

**Projects may be used for commercial endeavors in any quantity** unless specifically noted. No attribution is necessary, though a link back is always greatly appreciated. The only usage restrictions are that **(1) you cannot resell the PCB as part of a kit without prior arrangement, and (2) you cannot “goop” the circuit, scratch off the screenprint, or otherwise obfuscate the circuit to disguise its source.** (In other words: you don't have to go out of your way to advertise the fact that you use these PCBs, but please don't go out of your way to hide it. The guitar effects industry needs more transparency, not less!)

## DOCUMENT REVISIONS

---

### 1.1.0 (2020-06-06)

Updated PCB layout to add two resistors. Added additional tracing notes based on analysis of two vintage units.

### 1.0.1 (2019-08-21)

Removed RPD from parts list, mistakenly copied from another project.

### 1.0.0 (2019-02-01)

Initial release.